

MERIDIAN

BULK SEED TENDER OPERATOR'S MANUAL



FOR OWNERS OF MODEL SEED TITAN SR2

PRODUCT WARRANTY REGISTRATION FORM



WARRANTY REGISTRATION

This form must be filled out by the dealer and signed by both the dealer and the customer at the time of delivery. Please mail or fax the completed form for validation of the equipment registration.

Customer's Name _____

Address _____

City, State, Postal Code _____, _____, _____

Phone Number (_____) _____ - _____

PRODUCT INFORMATION

Tender Model # _____

Serial Number # _____

DEALER INSPECTION REPORT

___ Tender frame secured to trailer

___ Electric brakes in working condition

___ Check fuel level and gas shut-off

___ All guards/shields installed correctly

___ Check engine oil level

___ All safety signs installed and intact

___ Check reduction case oil level

___ Reflectors and lights clean and legible

___ Check hydraulic tank oil level

___ Review safety and operating instructions

___ Start Kohler® engine

___ Inspect customer's hitch for 2-5/16" ball/gooseneck hitch

___ Check brake and lighting harness connection

___ Verify receipt of all options ordered

___ Check remote throttle control functions

___ Check air pressure in tires

___ Lubricate unit where necessary

I have thoroughly instructed the buyer on the above-described equipment, including review of the Operator's Manual content, equipment care, adjustments, operational use, safety procedures, and applicable warranty policy.

Dealer/Company Name _____

City, State, Postal Code _____, _____, _____

Dealer's Signature _____ Date ____/____/____

The above equipment and Operator's Manual have been received by me, and I have been thoroughly instructed as to care, adjustments, safe operation, and applicable warranty policy.

Owner's Signature _____ Date ____/____/____



2902 Expansion Blvd.
Storm Lake, IA 50588
PH# 712-732-1780
FAX# 712-732-1028

Date: ____/____/____

CERTIFICATE OF ORIGIN

LICENSING INFORMATION

DEALER:

Business

Contact

Address

City, State, Zip

SOLD TO:

Business

Contact

Address

City, State, Zip

TENDER MODEL # _____ TENDER WEIGHT _____ TENDER SN _____
(One serial number is issued for the tender and the Trailer will receive a separate serial number)

TRAILER MODEL #: _____ TRAILER SERIAL # _____ TRAILER WEIGHT: _____

Tender 110 BST Wagon	8011 0	1004#	Tender 375 (no trailer)	8034 9	4207#
Tender 110 BST-T (trailer included)	8011 1	1830#	Tender 375-BH	8034 5	6071#
Tender 225 RST Wagon	8013 1	1733#	Tender 375-GN	8034 6	6721#
Tender 225 RST-BH	8060 1	3375#	Tender 375-BWT-BH	8034 7	6079#
Tender 225RST-GN	8060 2	4097#	Tender 375BWT-GN	80348	6729#
Tender 225RST-BWT-BH	8060 3	3577#	Tender 375RT8-BWT (trailer included)	80377	5913#
Tender 225RST-BWT-GN	8060 4	4299#	Tender 375RT8-T (trailer included)	80379	5607#
Tender 240RT6	8024 9	2545#	Tender 400-6SLD	80352	3375#
Tender 240RT6-BWT-BH	8025 3	4475#	Tender 400BH-6SLD	80353	5040#
Tender 240RT6-BH	8025 0	4174#	Tender 400GN-6SLD	80354	5690#
Tender 240RT8	8025 1	2604#	Tender 400-8SLD	80355	3530#
Tender 240RT8-BWT-BH	8024 8	4534#	Tender400BH-8SLD	80356	5195#
Tender 240RT8-GN	8025 5	4232#	Tender 400GN-8SLD	80357	5845#
Tender 240RT8-BWT-GN	8024 3	4491#	840 SR2 Tender	80409	18000#
Tender 375RT6 Wagon	8038 1	3094#	1050 SR2 Tender	80419	19400#
Tender 375RT6-BH	8032 4	5636#	1260 SR2 Tender	80420	21000#
Tender 375RT6-BWT-BH	8033 7	5942#	Titan SR2 2 Box w/Auger (no Trailer)	80143	2500#
Tender 375RT6-GN	8033 8	6637#	Titan SR2 2 Box w/Conveyor (no Trailer)	80144	2700#
Tender 375RT8	8038 2	3476#	Titan SR2 2 Box w/Auger BH Trailer	80141	2800#
Tender 375RT8 Wagon	8037 6	3106#	Titan SR2 2 Box w/conveyor BH Trailer	80142	3000#
Tender 375RT8 -BH	8032 6	5760#	Titan SR2 4 Box w/ Auger (no trailer)	80145	4150#
Tender 375RT8-GN	8032 7	6441#	Titan SR2 4 Box w/ Conveyor (no Trailer)	80146	4250#
Tender 375RT8-BWT-BH	8033 9	5990#	Titan SR2 4 Box w/Auger BH Trailer Tandem	80412	4500#
Tender 375RT8 -GN	8034 0	6672#	Titan SR2 4 Box w/Conveyor BH Trailer Tandem	80413	4600#
240 -Rear Facing (BH trailer included)	8012 1	3720#	Titan SR2 4 Box w/Auger GN Trailer Tandem	80414	5100#
240 -Front Facing (BH trailer included)	8013 6	3720#	Titan SR2 4 Box w/Conveyor GN Trailer Tandem	80415	5200#
			Titan SR2 4 Box w/Auger GN Trailer Triple Axle	80416	5700#
			Titan SR2 4 Box w/Conveyor GN Trailer Triple Axle	80417	5800#
			Titan SR2 6 Box w/ Auger GN Trailer Triple Axle	80502	6500#
			Titan SR2 6 Box w/Conveyor GN Trailer Triple Axle	80503	6600#

Cut Here to Remove Page

IMPORTANT INFORMATION

SERIAL NUMBER LOCATION

Please provide the serial number of your Meridian Titan SR2 Seed Tender and engine when ordering parts or requesting service or other information.

The serial number plates are located where indicated. Please record the numbers in the space provided below for easy reference.

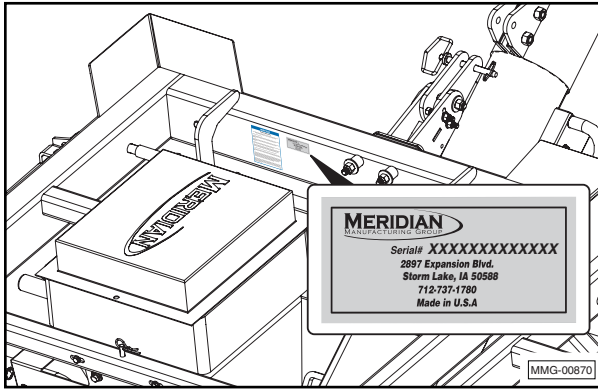

Seed Tender

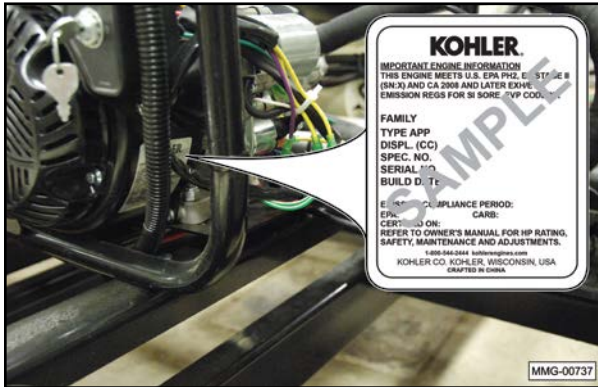

Engine

Model Number: Titan SR2

Serial Number: _____

Engine Serial Number: _____

PATENT INFORMATION



Meridian continuously enhances its product offering through product improvements and new product innovations. Marketplace feedback, technological innovation, new materials and manufacturing methods, and a philosophy of continuous improvement constantly challenge the company to develop new and better ways of addressing market needs. Meridian is committed to innovation and reinvestment and as a result, the company maintains a portfolio of patents and intellectual property. For more information on our patents please see our website: www.meridianmfg.com/patents

CONTENTS

1. INTRODUCTION	11
1.1 Congratulations	11
1.2 Operator Orientation	11
1.3 Owner/Operator	11
2. SAFETY	12
2.1 General Safety	13
2.2 Equipment Safety Guidelines	14
2.3 Safety Training	15
2.4 Safety Signs	15
2.5 Preparation	15
2.6 Transport Safety	15
2.7 Operating Safety	15
2.8 Storage Safety	15
2.9 Maintenance Safety	15
2.10 Lock-Out or Tag-Out Safety	15
2.11 Battery Safety	15
2.12 Refuelling Safety	15
2.13 Sign-Off Form	16
3. SAFETY SIGN LOCATIONS	17
3.1 Safety Signs	17
3.2 How to Install Safety Signs	17
3.3 Decal Locations	17
4. SPECIFICATIONS	20
4.1 Overall Titan SR2 Seed Tender Specifications	20
4.2 Bolt Specifications	21
4.2.1 Bolt Torque Values	21
4.2.2 Grade Markings Chart	21
5. MACHINE COMPONENTS AND CONTROLS	22
5.1 Component Nomenclature and Location	22
6. PRE-OPERATING INSTRUCTIONS	26
6.1 Safety	26
6.2 Machine Break-In Period	26
6.2.1 Before Starting	26
6.2.2 Inspections for 1/2, 5, and 10 Hours	26
6.3 Daily Pre-Operation Checklist	27
7. TOWING	28
7.1 Transport Safety	28
7.2 Connecting the Trailer	28
8. OPERATION	30
8.1 Operating Safety	30
8.2 Loading and Unloading Seed Boxes	30
8.3 Transferring Seed to Planter	32
8.4 Talc Applicator	37
8.5 Unplugging Conveyor	37
9. STORAGE	38
9.1 Storage Safety	38
9.2 General Information	38
9.3 Placing in Storage	38
9.4 Removing from Storage	38

10. MAINTENANCE	39
10.1 Safety	39
10.1.1 General Safety	39
10.1.2 Lock-Out or Tag-Out Safety	39
10.2 Lubrication	40
10.2.1 Wheel Bearings	40
10.3 Battery	40
10.3.1 Battery Safety	40
10.3.2 Battery Replacement and Maintenance Tips	40
10.3.3 Battery Maintenance	41
10.4 Engine	41
10.4.1 Refuelling Safety	41
10.4.2 Approved Fuel	41
10.4.3 Engine Oil	41
10.4.4 Checking Engine Oil Level	41
10.4.5 Changing Engine Oil	42
10.4.6 Checking Reduction Case Oil Level	42
10.4.7 Changing Reduction Case Oil	43
10.4.8 Clean Air Cleaner	43
10.5 Conveyor Rollers	43
10.6 Conveyor Rotation Brake Adjustment	44
10.7 Conveyor Removal	45
10.8 Conveyor Installation	45
10.9 Unplugging	46
10.10 Conveyor Tube	47
10.10.1 Belt Tension Adjustment	47
10.10.2 Belt Tracking Adjustment	47
10.10.3 Belt Replacement	47
10.11 Hydraulic System	48
10.11.1 Hydraulic Oil Change	48
10.11.2 Hydraulic Pump Coupling	49
10.11.3 Hydraulic Motor Coupling	49
10.12 Trailer Break-Away System	50
10.12.1 Testing the Battery	50
10.12.2 Charging Battery	50
10.12.3 Replacing Battery	50
10.13 Wheel Bolt Torque Requirements	51
10.14 Axle Bolts, Frame Hold-Down Bolts, and Trailer Hitch Bolts	51
10.15 Service Record Chart	52
10.16 Service Checks	53
10.16.1 8 Hours or Daily	53
10.16.2 50 Hours	53
10.16.3 50 Hours or Weekly	53
10.16.4 100 Hours or Monthly	53
10.16.5 200 Hours or Semi-Annually	53
10.16.6 400 Hours or Annually	54
10.17 Axle Maintenance	54
10.17.1 First 200 Miles	54
10.17.2 3,000 Miles or 3 Months	54
10.17.3 6,000 Miles or 6 Months	54
10.17.4 12,000 Miles or 12 Months	54
10.18 Tires	54
10.19 Welding Repairs	54
11. TROUBLESHOOTING	55
11.1 Troubleshooting Chart	55

12. OEM LITERATURE	56
12.1 Kohler® Engine	56
13. WARRANTY	57
13.1 Warranty Statement.	57
14. PARTS	58
14.1 Titan SR2 Seed Tender Frame 32384	58
14.2 Titan SR2 Conveyor Assembly	60
14.3 Titan SR2 Auger Assembly	62
14.4 Titan SR2 Delivery Chute & Slide Gates 32461	64
14.5 Titan SR2 Carriage Assembly	65
14.6 Titan SR2 Power Unit.	66
14.7 Titan SR2 Gooseneck Hitch Assembly	67
14.8 Titan SR2 Trailer Hitch Assembly	68
14.9 Titan SR2 Trailer Assembly	69

1. INTRODUCTION

1.1 CONGRATULATIONS

Congratulations on your choice of a Meridian Manufacturing Group Titan SR2 Bulk Seed Tender to complement your seed delivery system in your farming operation. This equipment has been designed and manufactured to meet the exacting standards for such equipment in the agricultural industry and will keep your seed delivery system at optimum efficiency.



The Bulk Seed Tender system is designed to handle any kind of bulk seed, quickly transport it, and then transfer it into planters and drills, as required.

Safe, efficient, and trouble-free operation of your Bulk Seed Tender requires that you and anyone else who will be operating or maintaining the machine, read and understand the Safety, Operation, Maintenance, and Troubleshooting information contained within this Operator's Manual.

This manual covers the Titan SR2 model manufactured by Meridian Manufacturing Group, Inc. The Titan SR2 model is supplied in single axle, tandem axle, and triple axle versions carrying two, four, or six seed boxes, respectively. Use the Table of Contents as a guide to locate required information.

1.2 OPERATOR ORIENTATION

The directions left, right, front, and rear, as mentioned throughout this manual, are as seen from the truck drivers' seat and facing in the direction of travel.

1.3 OWNER/OPERATOR

It is the responsibility of the owner or operator to read this manual and to train all other operators before they start working with the machine. Follow all safety instructions exactly. Safety is everyone's business. By following recommended procedures, a safe working environment is provided for the operator, bystanders, and the area around the work site. Untrained operators are not qualified and must not operate the machine.

In addition to the design and configuration of equipment, hazard control and accident prevention are dependent upon the awareness, concern, prudence, and proper training of personnel involved in the operation, transport, maintenance, and storage of equipment. It is the responsibility of the owner or operator to read this manual and to train all operators before they start working with the machine. Follow all safety instructions as laid out in this manual.

Keep this manual handy for easy reference and to pass on to new operators or owners. Call your Meridian Manufacturing Group, Inc. dealer if you need assistance, information, or additional copies of the manuals.

The information, specifications, and illustrations in this manual are those in effect at the time of printing. We reserve the right to change specifications or design at any time without notice.

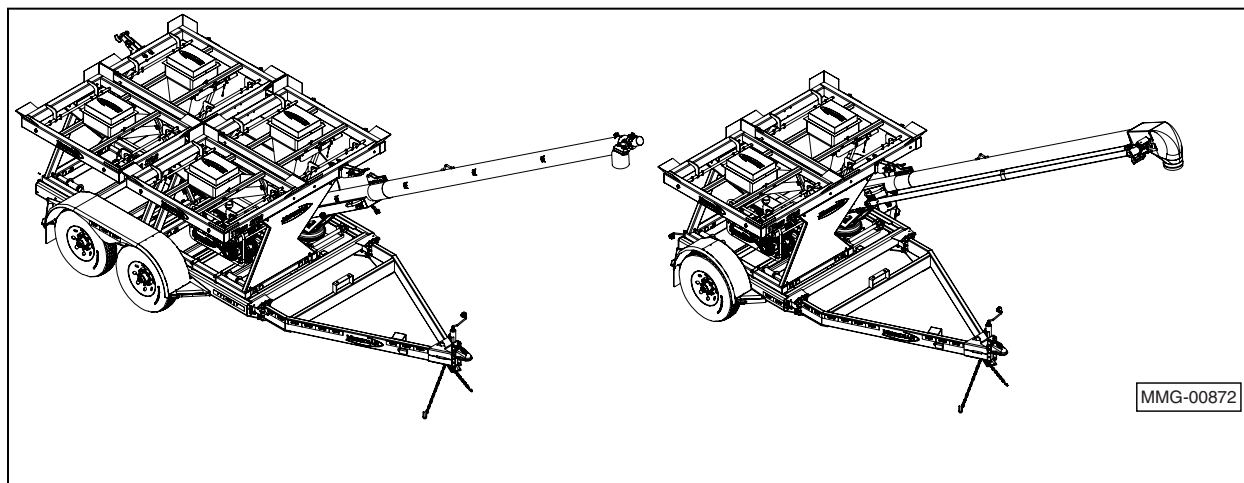

2. SAFETY

SAFETY ALERT SYMBOL

This Safety Alert symbol means
ATTENTION! BECOME ALERT!
YOUR SAFETY IS INVOLVED!



The Safety Alert symbol identifies important safety messages on the Meridian Bulk Seed Tender Models and in the manual. When you see this symbol, be alert to the possibility of personal injury or death. Follow the instructions in the safety message.

WHY IS SAFETY IMPORTANT TO YOU?

3 Big Reasons

- Accidents Disable and Kill •
- Accidents Cost •
- Accidents Can Be Avoided •

SIGNAL WORDS:

Note the use of the signal words **DANGER**, **WARNING**, and **CAUTION** with the safety messages. The appropriate signal word for each message has been selected using the following guidelines:

CAUTION

CAUTION - Indicates a potentially hazardous situation that, if not avoided, may result in minor or moderate injury. It may also be used to alert against unsafe practices.

WARNING

WARNING - Indicates a potentially hazardous situation that, if not avoided, could result in death or serious injury, and includes hazards that are exposed when guards are removed. It may also be used to alert against unsafe practices.

DANGER

DANGER - Indicates an imminently hazardous situation that, if not avoided, will result in death or serious injury. This signal word is to be limited to the most extreme situations, typically for machine components which, for functional purposes, cannot be guarded.

If you have any questions not answered in this manual, require additional copies of the manual, or the manual is damaged, please contact your dealer or Meridian Manufacturing Group, 2902 Expansion Blvd., Storm Lake, Iowa, 50588, toll free 1-800-437-2334, phone (712) 732-1780, or fax (712) 732-1028.

NOTICE

Indicates that equipment or property damage can result if instructions are not followed.

SAFETY INSTRUCTIONS

Safety instructions (or equivalent) signs indicate specific safety-related instructions or procedures.

Note: Contains additional information important to a procedure.

YOU are responsible for the **SAFE** operation and maintenance of your Meridian Manufacturing Group Bulk Seed Tender. **YOU** must ensure that you and anyone else who is going to operate, maintain, or work around the Bulk Seed Tender be familiar with the operating and maintenance procedures and related **SAFETY** information contained in this manual. This manual will take you step-by-step through your working day and alert you to all good safety practices that should be adhered to while operating the Bulk Seed Tender system.





Remember, **YOU** are the key to safety. Good safety practices not only protect you but also the people around you. Make these practices a working part of your safety program. Be certain that **EVERYONE** operating this equipment is familiar with the recommended operating and maintenance procedures and follow all the safety precautions. Most accidents can be prevented. Do not risk injury or death by ignoring good safety practices.

- Bulk Seed Tender system owners must give operating instructions to operators or employees before allowing them to operate the machine, and then annually thereafter per OSHA (Occupational Safety and Health Administration) regulation 1928.57.
- The most important safety feature on this equipment is a **SAFE** operator. It is the operator's responsibility to read and follow **ALL** Safety and Operating instructions in the manual. Most accidents can be avoided.
- A person who has not read and understood all operating and safety instructions is not qualified to operate the machine. An untrained operator exposes himself and bystanders to possible serious injury or death. Always be



and stay alert to any possible unsafe operating or maintenance procedures or conditions.





- Do not modify the equipment in any way. Unauthorized modification may impair the function and/or safety of the components and systems and could affect the life of the equipment, possibly invalidating the warranty coverage.
- Think SAFETY! Work SAFELY!

2.1 GENERAL SAFETY

1.  Read and understand the Operator's Manual and all safety signs before operating, maintaining, adjusting, filling, unloading, or unplugging the Bulk Seed Tender system.
2.  Have a first aid kit available for use should the need arise and know how to use it.
3.  Have a fire extinguisher available for use should the need arise and know how to use it.
4.  Do not allow riders.
5. When working around or operating this equipment, wear appropriate personal protective equipment. This list includes but is not limited to:



- A hard hat
 - Protective shoes with slip resistant soles
 - Protective goggles, glasses, or face shield
 - Heavy gloves and protective clothing
 - Respirator
6.  Do not allow long hair, loose fitting clothing, or jewelry around equipment.
 7.  Install and secure all guards before starting.
 8.  Stop engine, remove ignition key, and wait for all moving parts to stop before servicing, repairing, adjusting, loading, filling, or unplugging.

-
9.   Establish a lock-out or tag-out policy for the work site. Be sure all personnel are trained in and follow all procedures. Lock-out or tag-out all power sources before working around loading/unloading equipment.
 10.  Clear the area of people, especially small children, before starting.
 11.  Review safety related items annually with all personnel who will be operating, using, or maintaining the Bulk Seed Tender system.

2.2 EQUIPMENT SAFETY GUIDELINES

1. Safety of the operator and bystanders is one of the main concerns in designing and developing a machine. However, every year many accidents occur which could have been avoided by a few seconds of thought and a more careful approach to handling equipment. You, the operator, can avoid many accidents by observing the following precautions in this section. To avoid personal injury or death, study the following precautions and insist those working with you, or for you, follow them.
2. In order to provide a better view, certain photographs or illustrations in this manual may show an assembly with a safety shield removed. However, equipment should never be operated in this condition. Keep all shields in place. If shield removal becomes necessary for repairs, replace the shield prior to use.
3. Never use alcoholic beverages or sedative drugs while operating this equipment. Consult your doctor about operating this machine while taking prescription medications.
4. Under no circumstances should young children be allowed to work with this equipment. Do not allow persons to operate or assemble this unit until they have read this manual and have developed a thorough understanding of the safety precautions and how it works. Review the safety instructions with all users annually.

5. This equipment is dangerous to children and persons unfamiliar with its operation. The operator should be a responsible, properly trained, and physically able person familiar with farm machinery and trained in this equipment's operations. If the elderly are assisting with farm work, their physical limitations need to be recognized and accommodated.
6. Never exceed the limits of a piece of machinery. If its ability to do a job, or to do so safely, is in question - **DON'T TRY IT.**
7. Do not modify the equipment in any way. Unauthorized modification may result in serious injury or death and may impair the function and life of the equipment.
8. In addition to the design and configuration of this implement, including Safety Signs and Safety Equipment, hazard control and accident prevention are dependent upon the awareness, concern, prudence, and proper training of personnel involved in the operation, transport, maintenance, and storage of the machine. Refer to Safety Messages and operation instructions in each of the appropriate sections of the auxiliary equipment and machine Manuals. Note all Safety Signs affixed to the auxiliary equipment.

2.3 SAFETY TRAINING

1. Safety is a primary concern in the design and manufacture of our products. Unfortunately, our efforts to provide safe equipment can be wiped out by a single careless act of an operator or bystander.
2. In addition to the design and configuration of equipment, hazard control and accident prevention are dependent upon the awareness, concern, prudence, and proper training of personnel involved in the operation, transport, maintenance, and storage of this equipment.
3. The best safety feature is an informed, careful operator. It is the operator's responsibility to read and comply with ALL Safety and Operating instructions in the manual. Accidents can be avoided.
4. Working with unfamiliar equipment can lead to injuries. Read this manual, as well as the manual for your auxiliary equipment, before assembling or operating to acquaint yourself with the machines. If this machine is used by any person other than yourself, it is your responsibility to make certain that the operator reads and understands the operator's manuals and is instructed in safe and proper use.
5. Know your controls and how to immediately stop the conveyor and any other auxiliary equipment in an emergency. Read this manual and the one provided with all auxiliary equipment.
6. Train all new personnel and review instructions frequently with employees. Be certain only a properly trained and physically able person will operate the machinery. A person who has not read and understood all operating and safety instructions is not qualified to operate the machine. An untrained operator exposes himself and bystanders to possible serious injury or death.

2.4 SAFETY SIGNS

Refer to "3.1 Safety Signs" on page 17 for safety information.

2.5 PREPARATION

Refer to "6.1 Safety" on page 26 for safety information.

2.6 TRANSPORT SAFETY

Refer to "7.1 Transport Safety" on page 28 for safety information.

2.7 OPERATING SAFETY

Refer to "8.1 Operating Safety" on page 30 for safety information.

2.8 STORAGE SAFETY

Refer to "9.1 Storage Safety" on page 38 for safety information.

2.9 MAINTENANCE SAFETY

Refer to "10.1 Safety" on page 39 for safety information.

2.10 LOCK-OUT OR TAG-OUT SAFETY

Refer to "10.1.2 Lock-Out or Tag-Out Safety" on page 39 for safety information.

2.11 BATTERY SAFETY

Refer to "10.3.1 Battery Safety" on page 40 for safety information.

2.12 REFUELLING SAFETY

Refer to "10.4.1 Refuelling Safety" on page 41 for safety information.

3. SAFETY SIGN LOCATIONS

3.1 SAFETY SIGNS

The types of safety signs and locations on the equipment are shown in the following pages. Good SAFETY AWARENESS requires that you familiarize yourself with the various safety signs, the type of warning and the area, or a particular function related to that area.

1.  If safety signs have been damaged, removed, become illegible, or parts replaced without signs, new signs must be applied.
2. Replacement parts that displayed a safety sign should also display the current sign.
3. Replacement safety signs (labels) are available from your authorized Dealer Parts Department or the factory at no cost.

3.2 HOW TO INSTALL SAFETY SIGNS

1. Be sure that the installation area is clean and dry.
2. Be sure temperature is above 50°F (10°C).
3. Determine exact position before you remove the backing paper.
4. Remove the smallest portion of the split backing paper.
5. Align the sign over the specified area and carefully press the small portion with the exposed sticky backing in place.
6. Slowly peel back the remaining paper and carefully smooth the remaining portion of the sign in place.
7. Small air pockets can be pierced with a pin and smoothed out using a piece of sign backing paper.

3.3 DECAL LOCATIONS

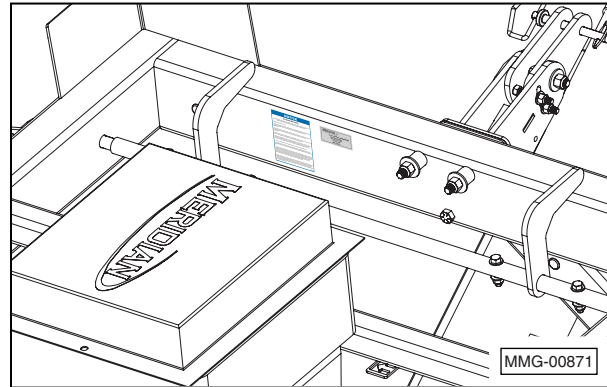

1. NOTICE — Product Warranty (#18432)

NOTICE

Product Warranty

Meridian Manufacturing Group (hereinafter "Meridian") warrants all products manufactured by it to be free of defect in material and workmanship for a period of (1) year from the date of purchase.

This Meridian warranty does not cover:

1. Accessories supplied by Meridian but manufactured by others. Meridian will facilitate the other manufacturer warranty for the benefit of the purchaser but will not be bound thereby (example: augers, trailers, agitators, etc.).
2. Products that have been altered by anyone other than a Meridian employee or are used by the purchaser for the purposes other than what was intended at time of manufacture or used in excess of the "built specifications".
3. Products that are custom manufactured by Meridian utilizing the purchaser's design which deviates from the Meridian normal production line manufacture or customized features of the products.
4. Malfunction or damages to the product from misuse, negligence, customer alteration, accidents or product abuse due to incoming material or poor material flow ability or lack of required performance or required maintenance (e.g., poor material flow ability caused by incoming wet fertilizer or hot soybean meal, etc.).
5. Loss of time, inconvenience, loss of material, down time or any other consequential damage.
6. Product used for a function that is different than designed intent (e.g., storing soybean meal in grain bin, unacceptable material in the bin such as hot bean meal when product originally designed for other application, etc.).

To activate this warranty, the purchaser must make contact in writing with Meridian within one (1) year of date of purchase. After contact, Meridian has the right to determine the cause and qualify the legitimacy of the claim. Meridian, upon acceptance of a warranty claim shall have a reasonable time to plan any repair or replacement and may effect repair or replacement out of its factory or through contract with a local repair service. If a purchaser after warranty notice is made chooses to make the repair itself, Meridian must approve any expenses before they are incurred to be responsible for customer reimbursement.

Meridian shall be liable on a warranty claim for repair or replacement of any defective products and this is the purchaser's sole and exclusive remedy. Meridian will not be liable for any other or further remedy including claims for personal injury, property damage or consequential damage. The law of the State of Iowa shall govern and any such claim and any issues with regard to the same shall be resolved in the Iowa District Court for Buena Vista County, Iowa.

18432

2. Product Serial Number Decal (#19984)



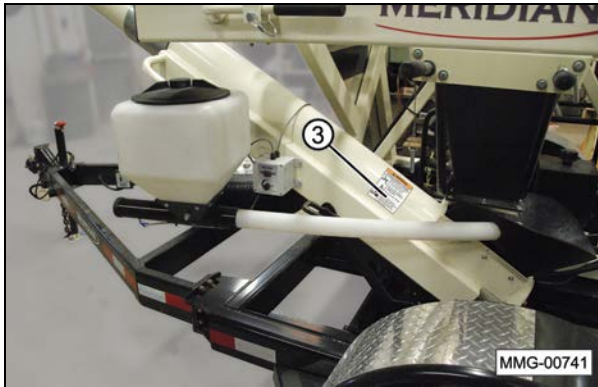

3. WARNING — Rotating Parts (#19936)

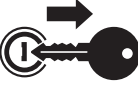
⚠ WARNING	
ENTANGLEMENT HAZARD	
  	<p>Avoid serious injury or death:</p> <ul style="list-style-type: none"> • Do not operate with access door open. • Do not place hands or fingers near rotating or moving parts. • Do not operate without guard. • Stop engine, remove ignition key, and wait for moving parts to stop before performing any work on unit. <p style="text-align: right; font-size: small;">19936</p>

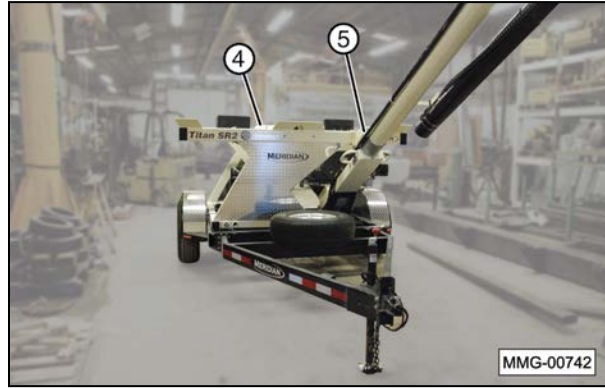

4. WARNING — Upending Hazard (#19938)

⚠ WARNING	
	
UPENDING HAZARD	
<p>To prevent serious injury or death:</p> <ul style="list-style-type: none"> • Do not stand over hitch when unhooking unit from tow vehicle. • FILLING: Fill front bin or load front seed box first to maintain downward pressure on hitch. • EMPTYING: Unload or empty rear bin or seed box first to maintain downward pressure on hitch. <p style="text-align: right; font-size: x-small;">19938</p>	

5. CAUTION — Read and Understand (#19934)

⚠ CAUTION	
	
<ul style="list-style-type: none"> • Read and understand the Operator's Manual before using. Review safety instructions annually. • Stop engine, remove ignition key, and wait for all moving parts to stop before servicing, repairing, adjusting, loading, filling, or unplugging. • Keep working area clean and free of debris to prevent slipping or tripping. • Do not allow riders on the trailer or frame when transporting. • Only enter seed compartment when it is empty. • Keep hands, feet, hair, and clothing away from moving parts. • Do not place hands, arms, or body between seed box and frame or lid to prevent pinching or crushing. Components can move unexpectedly. • Do not place hands, fingers, or arms between unloading auger tube segments when placing in unloading configuration. • Stay away from overhead power lines. Electrocutation can occur without direct contact. • Install and secure all guards before starting. • Use care when climbing on frame or ladder to prevent slipping or falling. • Do not smoke when refuelling or working around machine. • Fasten frame securely to trailer before transporting. • In two compartment seed tenders, always empty Compartment 2 first to prevent an unbalanced load. An unbalanced load can cause hitch to upend. <p style="text-align: right; font-size: x-small;">19934</p>	

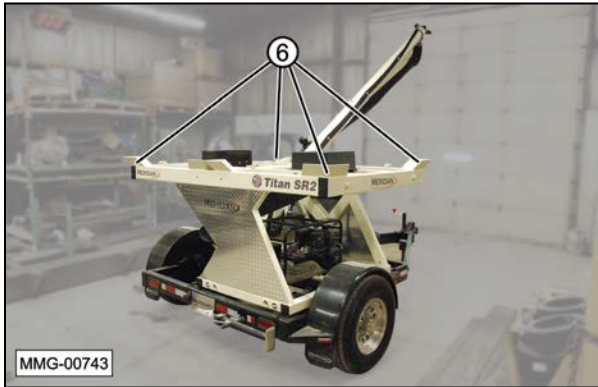

6. WARNING — Pinch Point (#19956)

 WARNING	
	
PINCH POINT HAZARD	
Avoid serious injury from pinching or crushing:	
<ul style="list-style-type: none">• Keep body parts clear of seed boxes and frame when loading.• Keep bystanders at least 15 ft. (4.5 m) away from loading area.	
19956	

4. SPECIFICATIONS

4.1 OVERALL TITAN SR2 SEED TENDER SPECIFICATIONS

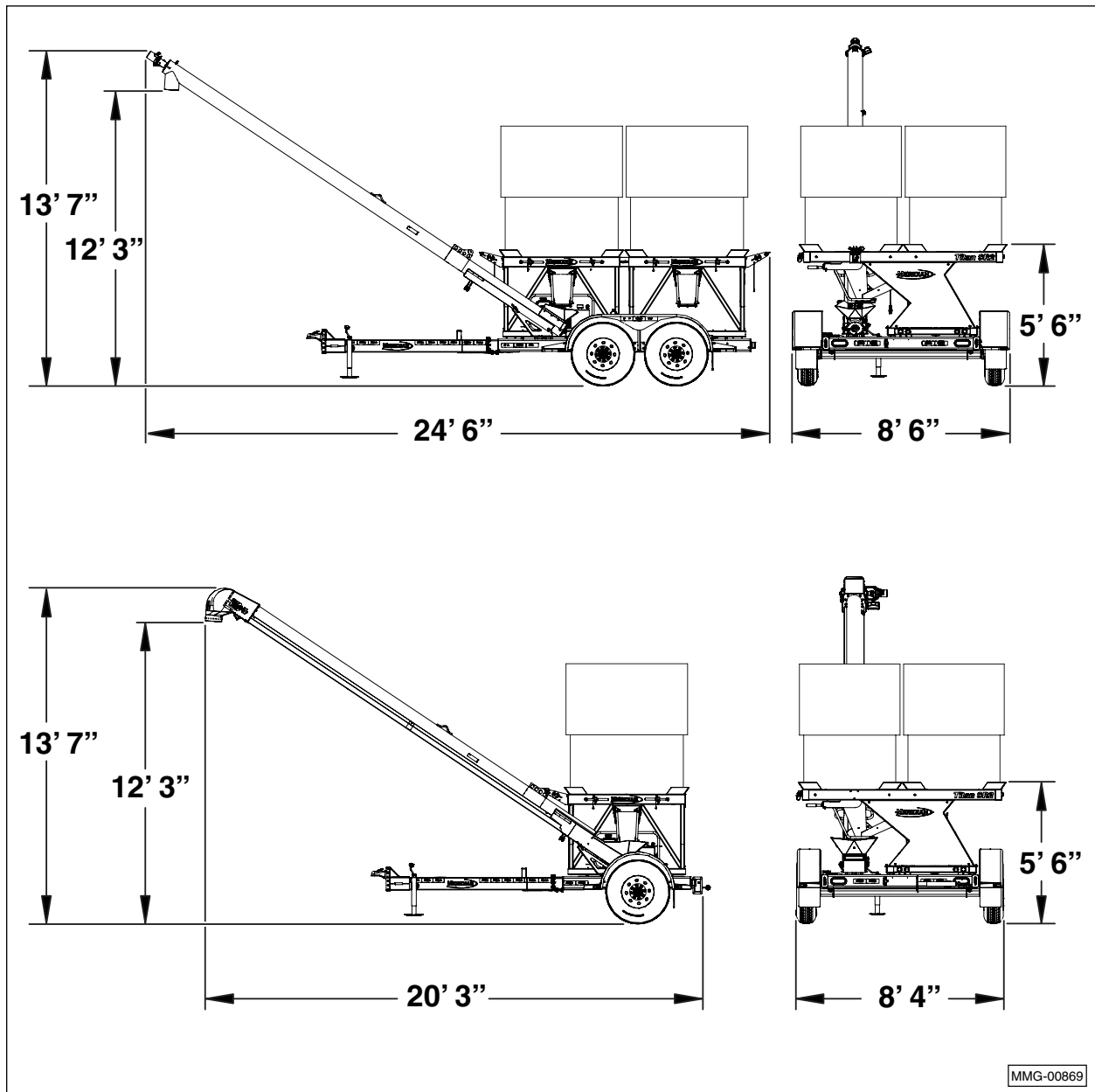

4.2 BOLT SPECIFICATIONS

⚠ WARNING

EQUIPMENT FAILURE



The torque value for bolts and capscrews are identified by their head markings. Replacing higher “Grade” bolts (Grade 8) with lower Grade bolts (Grade 5) will lead to equipment failure and can result in injury or death. Always use replacement bolts with the same Grade markings as the removed bolt.

4.2.1 Bolt Torque Values

Torque figures indicated above are valid for non-greased or non-oiled threads and heads unless otherwise specified. Therefore, do not grease or oil bolts or capscrews unless otherwise instructed in this manual. When using locking elements, increase torque values by 5%.

Bolt Diameter “A”	SAE Grade 2		SAE Grade 5		SAE Grade 8	
	N·m (ft-lbs)		N·m (ft-lbs)		N·m (ft-lbs)	
1/4"	8	(6)	12	(9)	17	(12)
5/16"	13	(10)	25	(19)	36	(27)
3/8"	27	(20)	45	(33)	63	(45)
7/16"	41	(30)	72	(53)	100	(75)
1/2"	61	(45)	110	(80)	155	(115)
9/16"	95	(70)	155	(115)	220	(165)
5/8"	128	(95)	215	(160)	305	(220)
3/4"	225	(165)	390	(290)	540	(400)
7/8"	230	(170)	570	(420)	880	(650)
1"	345	(225)	850	(630)	1320	(970)

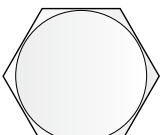
4.2.2 Grade Markings Chart

 No Marking	Grade 2 Low or Medium Carbon Steel
 3 Radial Lines	Grade 5 Medium Carbon Steel Quenched and Tempered
 6 Radial Lines	Grade 8 Medium Carbon Alloy Steel, Quenched and Tempered

5. MACHINE COMPONENTS AND CONTROLS

5.1 COMPONENT NOMENCLATURE AND LOCATION

The Meridian Titan SR2 Seed Tender is designed as a bulk seed transfer unit to transport large amounts of seed into a planter or drill.

Bulk seed boxes are loaded onto the seed tender frame. The conveyor then transfers the seed from the seed boxes into a planter or drill. Slide gates on the unit control the flow of seed into the conveyor.

A gas engine and hydraulic pump mounted on the frame powers a hydraulic motor. A reduction case centrifugal clutch on the engine output shaft engages when the engine speed reaches 1400 RPM. The hydraulic drive system transmits power from the engine to the conveyor or auger. The throttle switch is used to increase or decrease the speed of the conveyor.

Note: The tender may be equipped with a cleated belt conveyor or an auger. The word “conveyor”, as used in this manual, refers to either unloading device, as equipped.

The conveyor will unload to the left side, out of the back of the unit, or out of the front of the unit.

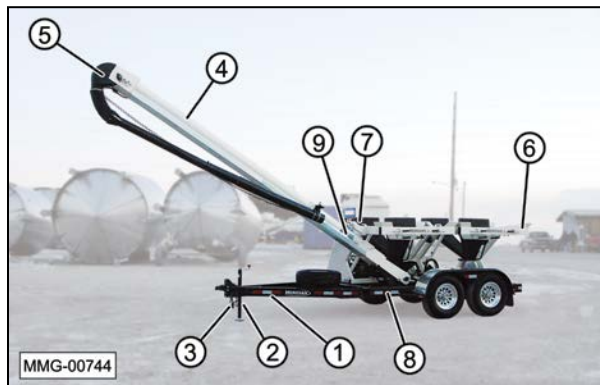

- (1) Break-Away Trailer Brake System.
- (2) Trailer Jack. (3) Safety Chains.
- (4) Conveyor Tube. (5) Discharge Spout.
- (6) Seed Box Frame. (7) Document Storage Tube.
- (8) Trailer Frame. (9) Conveyor Tube Lock.

Once the seed boxes are loaded, the conveyor transfers the seed through the conveyor tube and discharge spout into planters or drills. Slide gate levers (10) on the unit control the flow of seed into the conveyor.

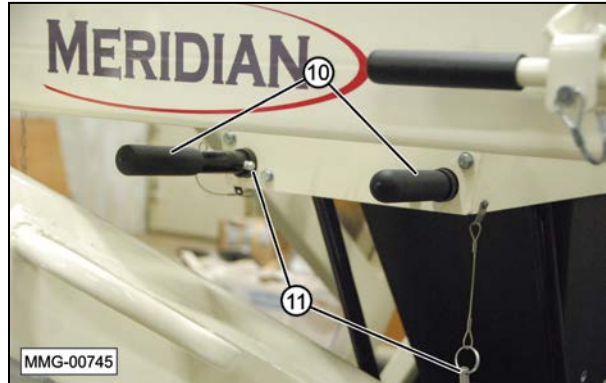

- (10) Open/Close Slide Gate Handles.
- (11) Slide Gate Lock Pins.

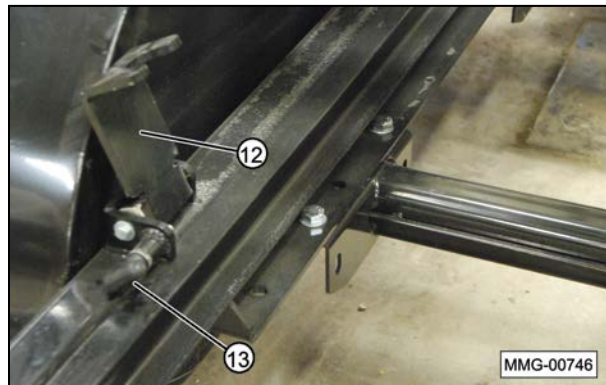

- (12) Trolley Lock Plate. (13) Locking Pin.

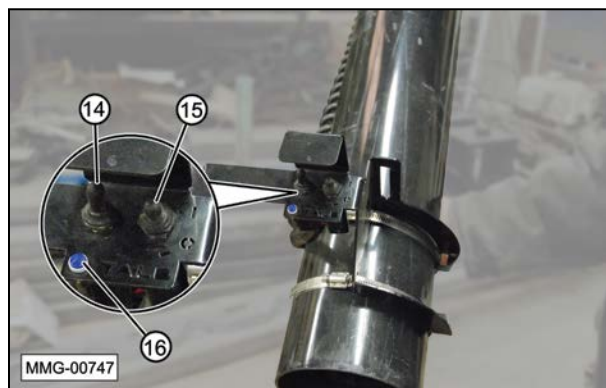

- (14) Engine Speed Control Switch.
- (15) Talc On/Off Switch.
- (16) Talc On Indicator Light.

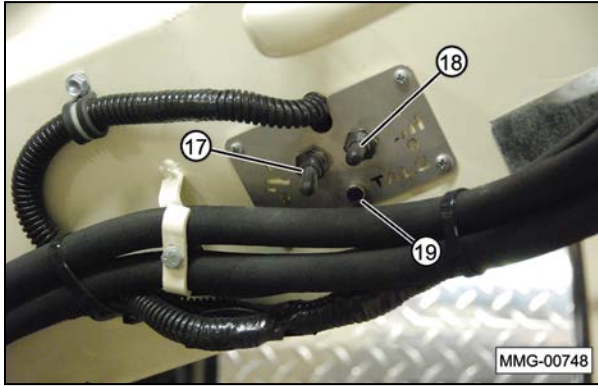

(17) Conveyor Rotation Brake Control Switch.
 (18) Engine Speed Control Switch.
 (19) Talc On Indicator Light.

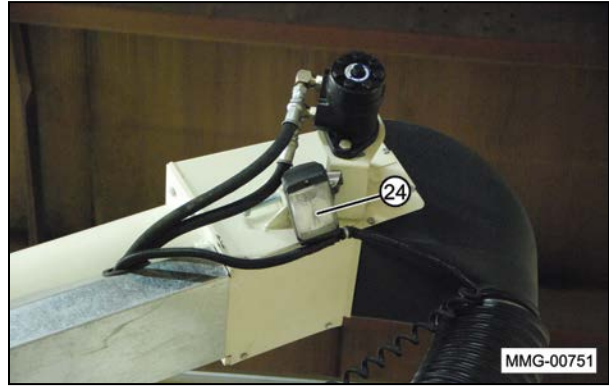

(24) Work Light.

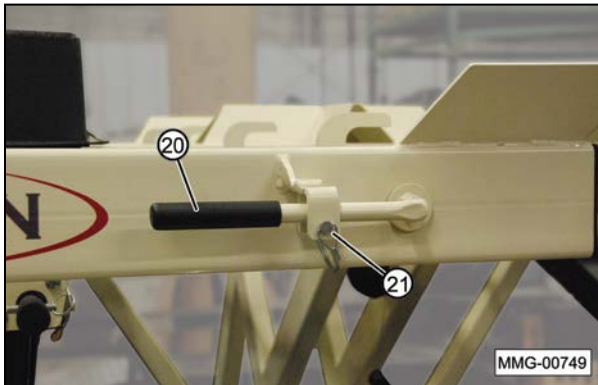

(20) Seed Box Latch Lever. (21) Lock Pin.



(25) Engine Work Light.

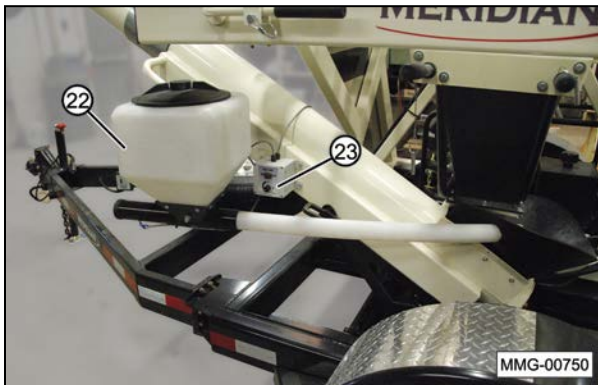

(22) Talc Hopper.
 (23) Talc Dispensing System Control Box.

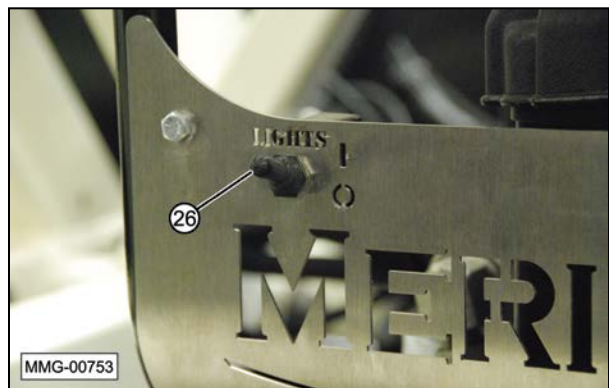

(26) Work Light Switch.

5.2 ENGINE AND CONTROLS

A Kohler® engine is used with this unit. Always read the engine Operator's Manual supplied with the seed tender for the detailed engine operating procedures.



1. Electrical System Key Switch

This key switch controls the power to the electrical system. Turn the key clockwise to turn the electrical system ON. The key will remain in the ON position when the engine is running. Turn the key counterclockwise to stop the engine.

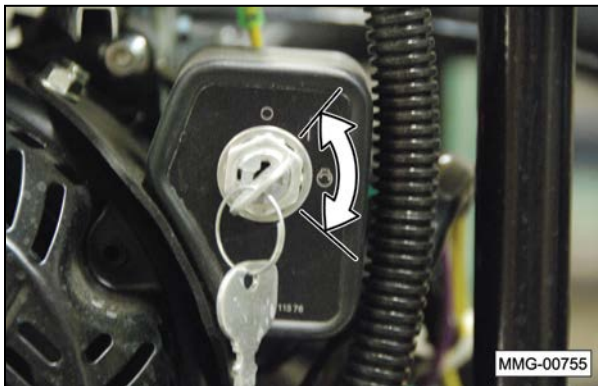

Turn the key switch to the START position to start the engine. When the engine starts, then release the key to allow it to return to the ON position.

2. Starting Rope

This retracting rope and T-bar is an optional method used to start the engine. Turn the key switch to the ON position. Grasp the T-bar firmly and pull the rope sharply to start the engine. The key switch must be in the ON position for the engine to run.

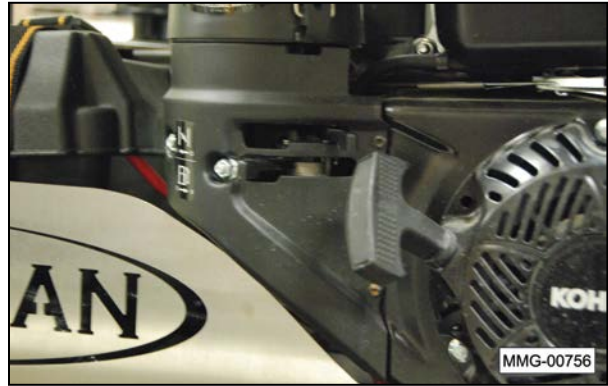

3. Throttle Actuator

The throttle actuator is an electronic unit to control the engine speed by a switch mounted at the end of the discharge spout. This allows the person filling the planter boxes to control the output flow of seed.



4. Choke Lever

The choke lever controls the fuel/air mixture to the engine. Close the choke when starting if the engine is cold. Open the choke as the engine warms. Always open the choke fully during operation.

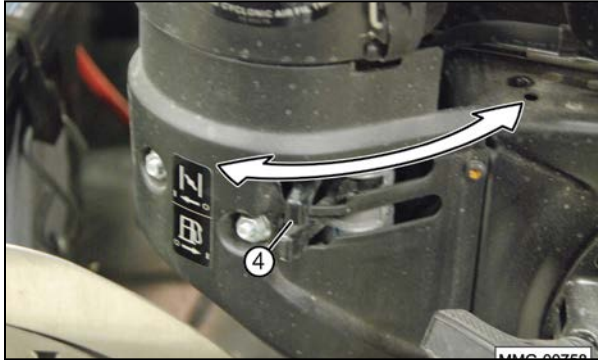

5. Fuel Shut-Off Valve

Each engine is equipped with a valve between the fuel tank and the carburetor. Slide the fuel valve toward the engine to turn ON and away for OFF. Turn the fuel OFF when not in use or before transporting.

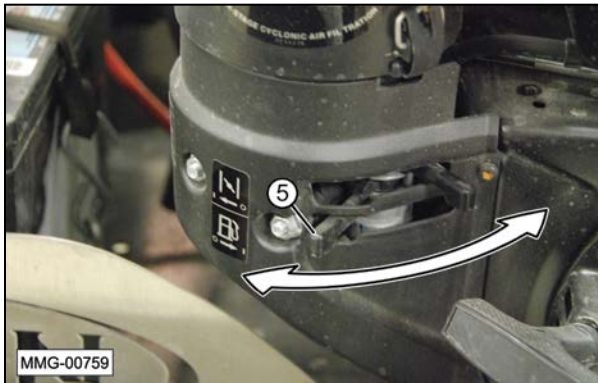

6. Battery (12 Volt)

A 12 Volt 250 CCA battery supplies the power to start the gasoline engine. The battery is recharged during operation.



5.3 ENGINE WARNING DECALS

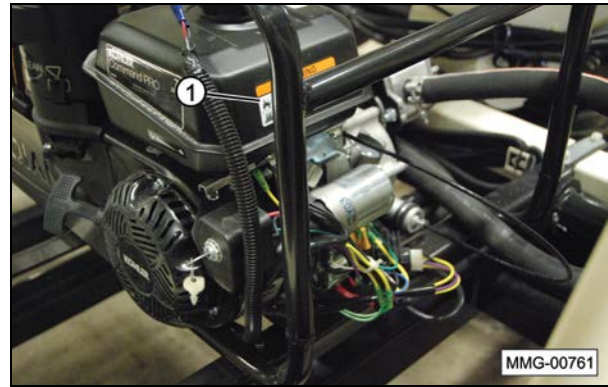

1. WARNING — Explosive Fuel (contact Kohler® Mfg. for replacement of this decal)

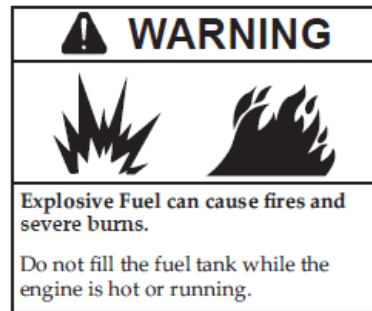



6. PRE-OPERATING INSTRUCTIONS

6.1 SAFETY

-  Never operate the seed delivery system and auxiliary equipment until you have read and completely understand this manual, the auxiliary equipment Operator's Manual, and each of the Safety Messages found on the safety signs on the delivery system and auxiliary equipment.



PROLONGED EXPOSURE TO LOUD NOISE MAY CAUSE PERMANENT HEARING LOSS! Motors or equipment can be noisy enough to cause permanent hearing loss. We recommend that you wear hearing protection on a full-time basis if the noise in the operator's position exceeds 80db. Note: Hearing loss from loud noise (tractors, chain saws, radios, and other such sources close to the ear) is cumulative over a lifetime with uncertain natural recovery.

-  Clear working area of debris, trash, or hidden obstacles that might be hooked or snagged, causing injury, damage, or tripping.
- Operate only in daylight or good artificial light.
- Be sure machine is properly attached to the trailer, adjusted, and in good operating condition.
-  Ensure that all guards, shielding, and safety signs are properly installed and in good condition.
-  Before starting, visually inspect the machine for any loose bolts, worn parts, cracks, leaks, frayed belts, or damage, and make necessary repairs. Always follow maintenance instructions.

6.2 MACHINE BREAK-IN PERIOD

A special break-in procedure has been developed to ensure the integrity of the seed tender when first put into service. Follow the Before Starting instructions and then follow the Inspections for 1/2, 5, and 10 Hours instructions at the appropriate interval.

After completing these instructions, follow the normal service schedule in the Maintenance section and engine manual.

6.2.1 Before Starting

- Read and follow the instructions in the Kohler® engine and the Meridian Operator's Manuals.
- Review and follow the Pre-operation Checklist before starting machine.
- Initially check wheel bolt torque and then again at 10, 25, and 50 miles. Refer to "10.13 Wheel Bolt Torque Requirements" on page 51 for tightening instructions.
- Start the engine and check the controls. Be sure that they function properly.

6.2.2 Inspections for 1/2, 5, and 10 Hours

- Recheck the engine and reduction case oil levels. Refill, as required.
- Recheck the hydraulic oil level. Add as required.
- Recheck hardware and fasteners; frame to trailer tie-downs, all fasteners, and wheel bolts. Tighten to their specified torque.
- At 10 hours, change the engine oil with the specified oil.

6.3 DAILY PRE-OPERATION CHECKLIST

Efficient and safe operation of the Meridian Bulk Seed Tender system requires that each operator reads and follows the operating procedures and all related safety precautions outlined in this section.

A pre-operational checklist is provided for the operator. It is important for both personal safety and maintaining the efficient operation of the delivery system that this checklist be followed.

Before operating the delivery system and each time thereafter, the following areas should be checked:

Check the engine oil level, reduction case oil level, hydraulic oil level, and fuel level. Add as required.





IMPORTANT

The engine warranty is void if the engine is run without oil.

5. Check hardware and fasteners; seed tender frame to trailer tie-downs, hitch bolts, trailer hitch to trailer bolts, and all other fasteners. Tighten to their specified torque.
6. Make sure the wheel bolt lug nuts are tight.
7. Check the tires and ensure that they are inflated to their specified pressure.
8. Remove all entangled material.
9. Visually inspect the conveyor, conveyor tube, and delivery spout for damage.
10. Test the break-away brake unit and the trailer brakes.
 - a. Make sure the trailer brakes are operating properly.
 - b. Make sure the trip wire to the break-away switch is connected to the tow vehicle.
 - c. Make sure the pin is correctly installed in the break-away switch.
 - d. Press the test button. The indicator should illuminate green. If the red light illuminates, the battery charge is low. Recharge the battery. If the battery will not hold a charge, replace the battery.

7. TOWING

7.1 TRANSPORT SAFETY

-  Comply with local, state, and federal laws governing safety and conveyance of farm machinery on public roads.
- Ensure all lights and reflectors are installed and in good working condition.
- Ensure that the trailer brakes are in good working order. Be familiar with their operation.
- Do not exceed a safe travel speed. Slow down for rough terrain and when cornering.
-  Fasten frame securely to the trailer before transporting.
- Be sure the trailer is securely hitched to the towing vehicle and a retainer is used through the hitch jaws. Always attach a safety chain between the hitch and the towing vehicle.
-  Stay away from overhead power lines. Electrocutation can occur without direct contact.
- Plan your route to avoid heavy traffic.
- Install conveyor spout transport lock before transporting.
-  Do not drink and drive.
- Be a safe and courteous driver. Yield to oncoming traffic in all situations, including narrow bridges, intersections, etc. Watch for traffic when operating near or crossing roadways.
-  Never allow riders on the tender or the trailer.

7.2 CONNECTING THE TRAILER

WARNING



UPENDING HAZARD

To prevent serious injury or death from upending hazard, do not stand over hitch when unhooking the trailer from the tow vehicle. On four box units, load seed boxes closest to the hitch first to keep weight on the hitch. Unload seed boxes closest to the rear of the trailer first to keep weight on the hitch.

- Complete the Pre-operation Checklist.

WARNING



CRUSH HAZARD

Ensure that all bystanders, especially small children, are clear of the working area. Ensure there is enough room and clearance to safely back up to the machine.

- Remove retainer clip (1). Release or open the receiver by lifting locking lever (2) into the open position.

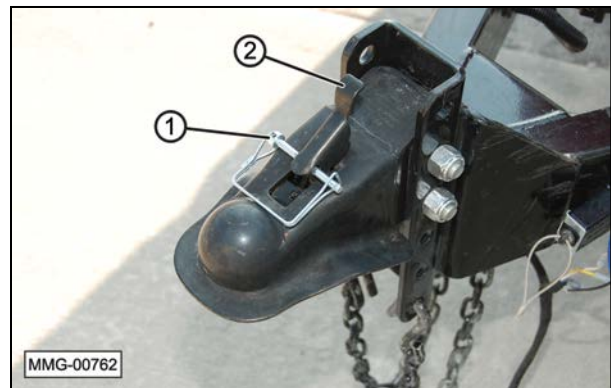

- Using the jack, raise the hitch above the ball on the tow vehicle.
- Slowly back the tow vehicle until the hitch and ball are aligned.

- Lower the hitch onto the ball.
- Raise the jack and place it in its stowed position.

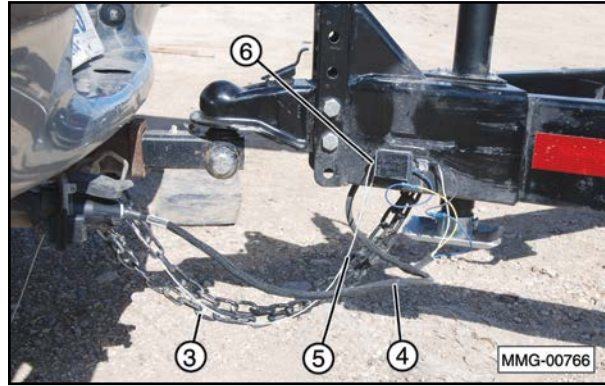

(The photo reflects a different trailer model; however, the hookup method is the same).

- Close the receiver lock lever and install the retainer clip to prevent unwanted opening of the receiver.

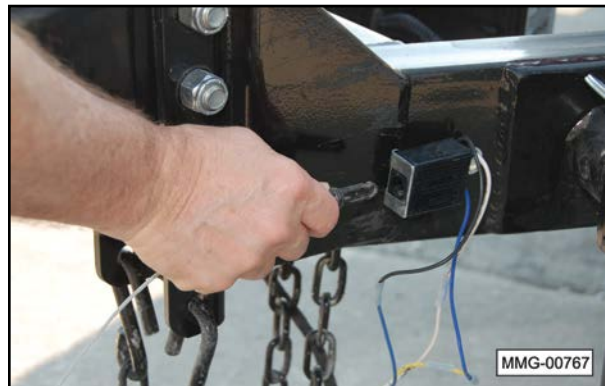
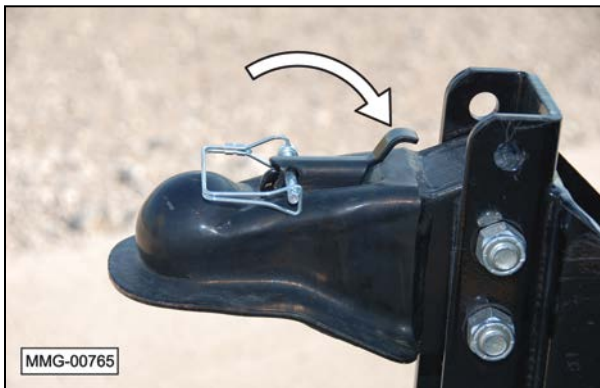

(The key must be completely plugged into the socket for the system to operate properly).

⚠ WARNING

⚠ If the safety chains are damaged in any way, do not use the trailer until proper chains are installed. Substandard or damaged safety chains could allow the trailer to separate from the tow vehicle, resulting in equipment damage, personal injury, or death.

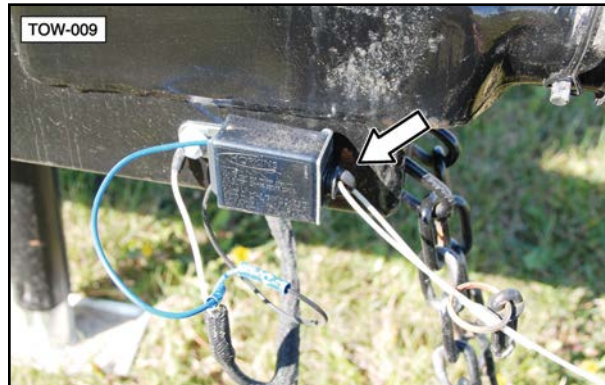















- Attach safety chains (3) securely to the tow vehicle to prevent unexpected separation. Cross the chains when attaching.
- Connect wiring harness (4) with the seven-pin connector for the lights and brakes.
- Connect breakaway system cable (5) to the tow vehicle. Make sure key (6) on the end of the cable is properly plugged into the receiving unit.

- Route all the cables in a manner that will prevent snagging. Be sure to provide slack for turning.

8. OPERATION

8.1 OPERATING SAFETY

-  Make sure that anyone who will be operating the Bulk Seed Tender system or working on or around the unit reads and understands all the operating, maintenance, and safety information in the operator's manual.
-  Keep all bystanders, especially children, away from the machine when loading or unloading, or when authorized personnel are carrying out maintenance work.
-   Establish a lock-out or tag-out policy for the work site. Be sure all personnel are trained in and follow all procedures. Lock-out or tag-out all power sources before servicing the unit or working around loading/unloading equipment.
-  Stop engine, remove ignition key, and wait for all moving parts to stop before servicing, repairing, adjusting, loading, filling, or unplugging.
-   Keep working area clean and free of debris to prevent slipping or tripping.
-  Do not allow riders on the trailer or frame when transporting.
-  Keep hands, feet, hair, and clothing away from rotating parts.
-  Do not place hands, fingers, or arms between moving parts.
-  Stay away from overhead power lines. Electrocutation can occur without direct contact.
-  Install and secure all guards before starting.
-  Use care when climbing on frame or ladder to prevent slipping or falling.
-  Fasten frame securely to trailer before transporting.
- Always empty seed boxes closest to the rear of the trailer first to prevent an unbalanced load. An unbalanced load can cause the tender to upend.

-  Review safety related items annually with all personnel who will be operating, using, or maintaining the seed delivery system.

8.2 LOADING AND UNLOADING SEED BOXES

The photos in this section represent the correct method for loading and unloading seed boxes from the unit. These photos may not represent the exact seed tender in this manual.

WARNING

PENDING HAZARD



Always load the front seed boxes first to maintain a positive tongue weight. Negative tongue weight can cause the hitch to rapidly swing upward if not securely fastened to the tow vehicle, which can result in personal injury.

WARNING



CRUSH HAZARD

Use caution when lifting seed boxes. A typical seed box can weigh 330 lbs. (150 kg.) when empty. Most seed boxes have the capacity of holding up to 2500 lbs. (1135 kg.) of seed. Keep bystanders away from the loading area and at least 15 ft. (4.5 m) from the seed box. Use a lifting device with a rated lift capacity capable of safely moving the seed boxes.

- Remove the retainer clips and open the two lock-down arms.

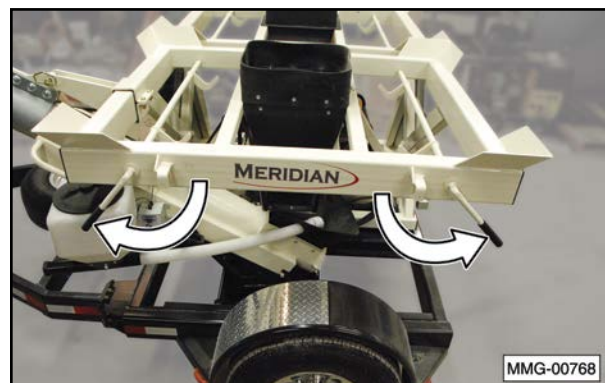

2. Lower the rear jack stand, if equipped.

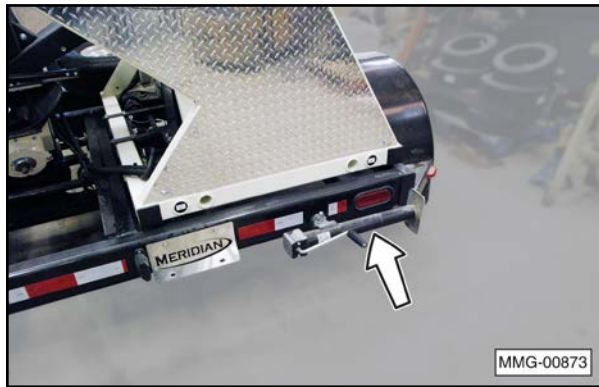

3. Remove the two hairpin retainer clips and remove the protective cover. Place the clips back into the retainer studs. Store the cover in a location that prevents it from being damaged.

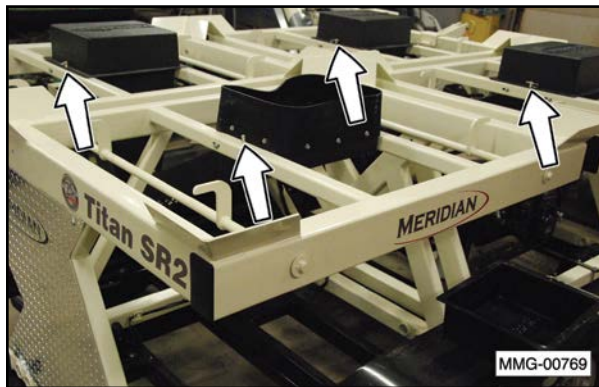

4. Make sure there are no foreign objects or impacted seed blocking the chute leading to the conveyor.



5. Make sure the frame is clear of debris and stand clear when placing the seed box onto the seed tender.



WARNING



PINCH POINT HAZARD

Avoid serious injury from pinching or crushing:

- **Keep body parts clear of seed boxes and frame when loading.**
- **Keep bystanders at least 15 ft. (4.5 m) away from loading area.**

19956

6. Using a suitable lifting device, carefully place the seed box onto the unit.

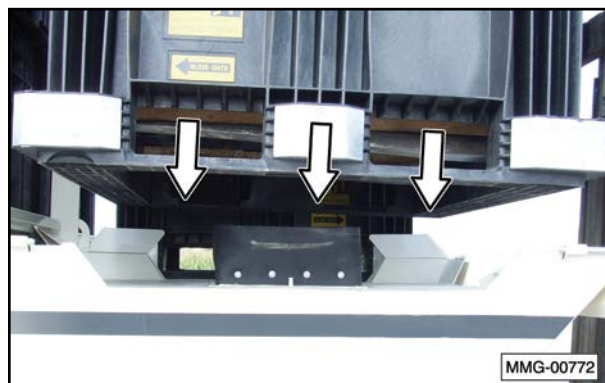

⚠ WARNING



CRUSH HAZARD

Do not remove the lifting device until you are sure the seed box and trailer are stable.

7. Make sure the seed box is loaded properly onto the unit.



8. Make sure the rubber boot contacts the bottom of the seed box.



9. Close both seed box lock-down arms. Insert the retaining pins and lock them in place.



⚠ WARNING



CRUSH HAZARD

Make sure the retainer pins are securely locked to keep the seed box attached to the unit.

10. Open the seed box gate valve.



8.3 TRANSFERRING SEED TO PLANTER

This section provides a step-by-step procedure for loading seed into the planter from the tender.

1. Position the seed tender near the planter.
2. Before unloading, shut off the engine of the tow vehicle, set the parking brake, remove the ignition key, and wait for all moving parts to stop before leaving the cab.
3. Check the surrounding area for overhead power lines that could contact the conveyor. **Contact with electricity can result in serious personal injury or death.**

⚠ WARNING

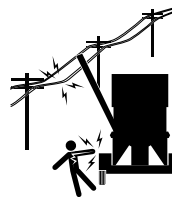

ELECTROCUTION HAZARD
Avoid contact with overhead power lines or electrically powered objects.

1. Be aware of your surroundings when raising or lowering any part of the equipment.
2. Maintain at least 20 feet between the equipment and any electrical hazard.
3. Contact with electricity can result in serious personal injury or death.

⚠ WARNING



UPENDING HAZARD

Always unload the rear seed boxes first to maintain a positive tongue weight. Negative tongue weight can cause the hitch to rapidly swing upward if not securely fastened to the tow vehicle, which can result in personal injury.

4. Remove the hairpin clip and the conveyor lock pin.

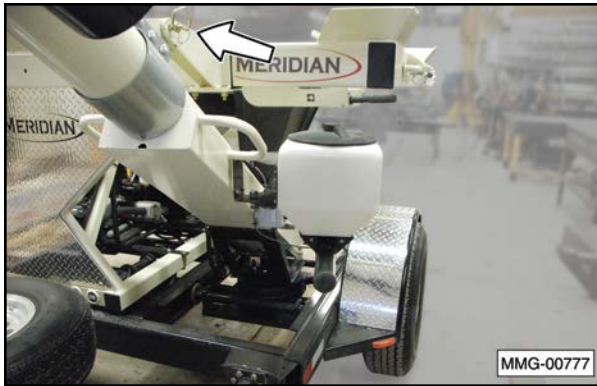

5. Rotate the conveyor to the desired position to reach the planter box.



6. Engage the brake to prevent the conveyor from rotating during unloading.

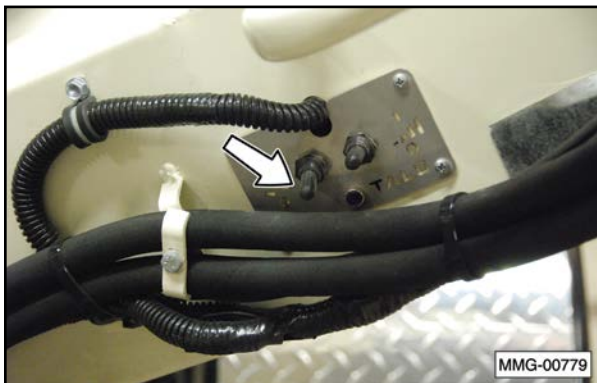

Note: The conveyor brake locks the rotation of the conveyor at any desired point. Make sure the brake is engaged before unloading the seed boxes.

7. Position the conveyor under the desired seed boxes by releasing the trolley lock plate and rolling the conveyor to the desired location.

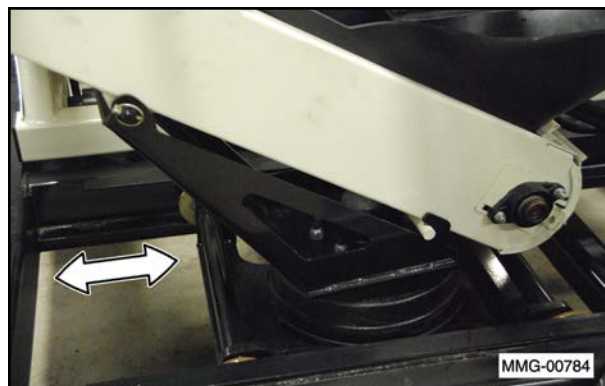
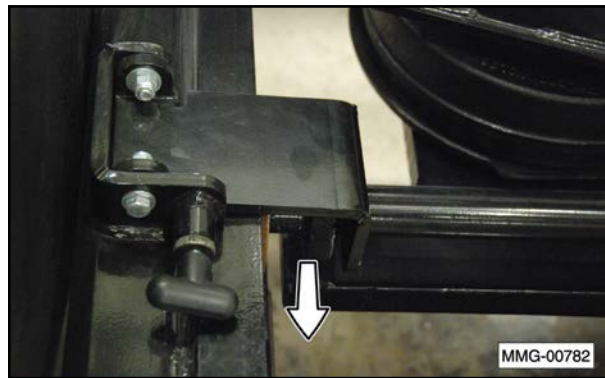

8. Make sure the trolley lock pin is engaged to prevent the trolley from moving during unloading.

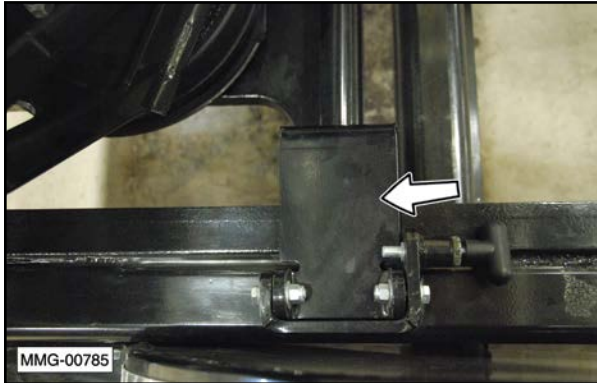

Note: Whenever the conveyor is repositioned, the rubber skirt, which directs the seed into the conveyor, can move out of its normal position. Before opening the slide gates, make sure the rubber boot on the conveyor completely surrounds the bottom of the bin chute.

On single axle units, anytime the conveyor is positioned toward the rear of the unit, away from the tongue, the rear jack stand must be lowered to support the weight of the conveyor.

⚠ WARNING



UPENDING HAZARD

Always maintain a positive tongue weight. Negative tongue weight can cause the hitch to rapidly swing upward if not securely fastened to the tow vehicle, which can result in personal injury.



9. Press and hold the remote throttle switch to move the throttle lever 1/3 the distance of the full open position. An electronic actuator is connected to the throttle lever to increase and decrease the speed of the engine.

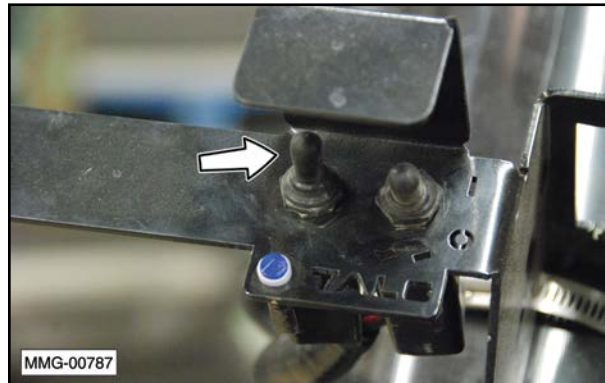

10. Start the gas engine.
 - a. Move fuel valve lever (1) to the ON position.
 - b. To start a cold engine, move choke lever (2) to the CLOSED position.

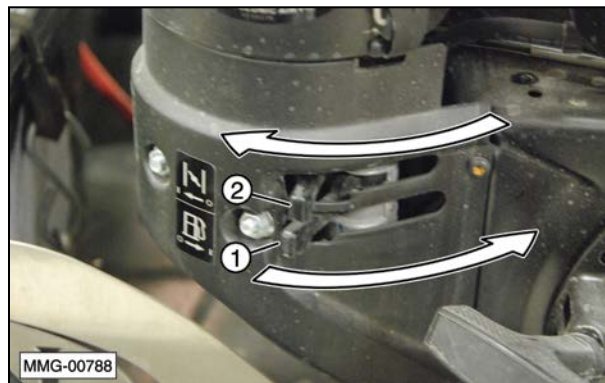

- c. Turn the key switch to the START position. Release the key switch when the engine starts. Allow the engine to warm up for two or three minutes. If the choke was closed to start the engine, gradually open it as the engine warms up.



- 11. If necessary, decrease the engine speed below 1400 RPM using the remote throttle control switch. A centrifugal clutch on the engine will engage and rotate the conveyor when the engine speed exceeds 1400 RPM. Increasing the engine speed will increase the unloading rate.

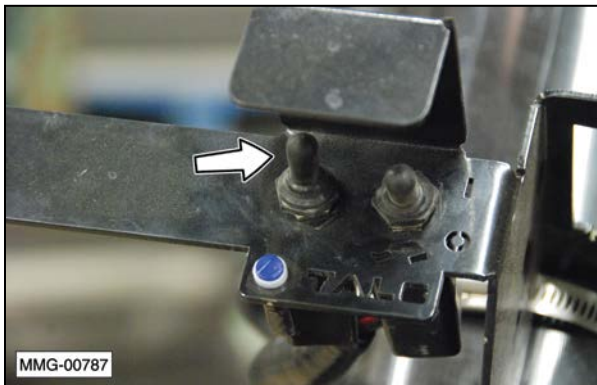

- 12. Remove lock pin (3) to release slide gate handles (4). Open the slide gate by pushing the handle inward. Close the slide gate by pulling the handle outward. The slide gate handle may be positioned at any intermediate position to adjust for the desired material flow.

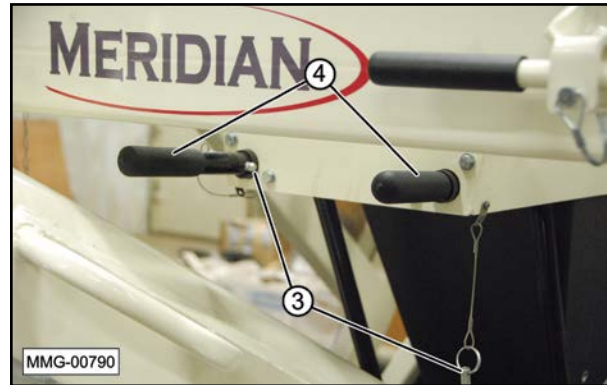

Note: The slide gate on the left is in the closed position with the lock pin in place. The slide gate on the right is in the open position with the lock pin removed.

- 13. Fill the planting equipment.

- a. Move the delivery spout to the seed box or bin and increase engine RPM to rotate the conveyor.
- b. When the seed box or bin is full, reduce the engine RPM to low idle to stop the conveyor.
- c. Move the delivery spout to the next box or bin and increase engine RPM to fill the next one. Repeat this procedure until the remaining boxes or bins are filled.

- 14. When the planter is nearly filled, close the slide gate and wait until the flow of seed stops.



15. When the transfer of seed is complete, press the conveyor speed control switch to reduce the engine RPM and stop the conveyor.

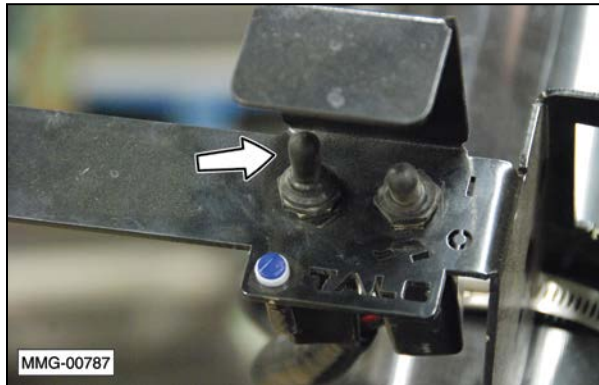

19. Before towing the unit on the road, return the conveyor to its transport position. Insert the lock pin and its retaining pin.



16. Replace the lock pin in the slide gate handle.

17. Turn the gas engine off.



20. Make sure the trolley lock plate is engaged to prevent the trolley from moving during transportation.

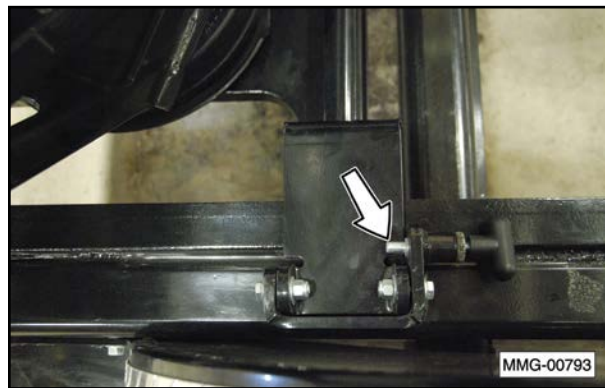

18. Place the engine's fuel lever in the OFF position before towing the seed tender on the open road.

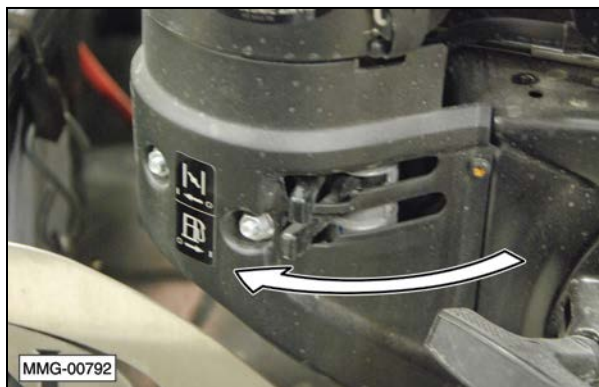

8.4 TALC APPLICATOR

For tenders equipped with the optional talc applicator, follow this procedure.

1. Fill the hopper with talc.



2. Switch the system on at the control box. Use the knob to set the desired flow rate.



3. The application is controlled from the switch on the discharge spout. The indicator light illuminates when talc is being dispensed.

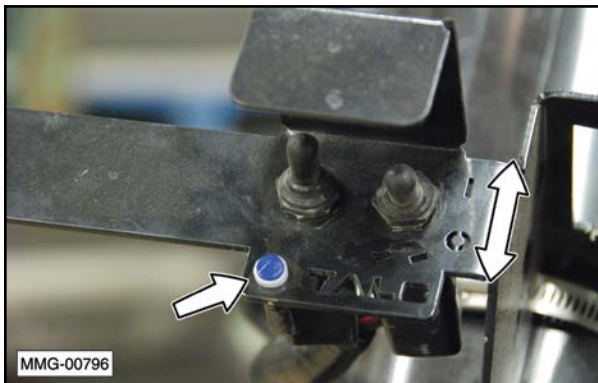

8.5 UNPLUGGING CONVEYOR

If the conveyor plugs, follow the procedure in “10.9 Unplugging” on page 46.

⚠ WARNING	
ENTANGLEMENT HAZARD	
	Avoid serious injury or death: <ul style="list-style-type: none">• Do not operate with access door open.• Do not place hands or fingers near rotating or moving parts.
	<ul style="list-style-type: none">• Do not operate without guard.
	<ul style="list-style-type: none">• Stop engine, remove ignition key, and wait for moving parts to stop before performing any work on unit.
19936	

9. STORAGE

9.1 STORAGE SAFETY

1. Store the unit in an area away from human activity.
2.  Do not permit children to play on or around the stored machine.
3. Store the unit in a dry, level area. Support the frame with planks, if required.

9.2 GENERAL INFORMATION

After planting or when the machine will not be used for a period of time, completely inspect all major systems of the seed tender. Replace or repair any worn or damaged components to prevent unnecessary downtime at the beginning of the next season.

IMPORTANT

To prevent component damage, store the seed tender in a dry, level area. If the seed tender is not attached to a trailer, support the frame with planks to raise the unit off the ground.

9.3 PLACING IN STORAGE

CAUTION



PERSONAL INJURY HAZARD
Store the unit in an area away from human activity. To prevent the possibility of serious injury, do not permit children to play on or around the stored machine.

1. Remove all seed from the seed tender.
2. Place the gasoline engine fuel valve in the OFF position.
3. Thoroughly wash the machine with a pressure washer or water hose to remove all dirt, mud, or debris.
4. Inspect rotating parts for entangled material. Remove all entangled materials.
5. Check the condition of the conveyor and delivery spout. Replace or adjust, as required.
6. Check the condition of the centrifugal clutch reduction case. Replace or adjust, as required.
7. Touch up paint nicks and scratches to prevent rusting.

8. Remove the ignition key and store in a secure place.
9. Remove the battery and store it in a cool, dry area on wooden blocks or a wooden pallet. Charge it monthly to maintain an adequate charge.
10. It is best to store the machine inside and if that is not possible, cover with a waterproof tarp and tie down securely.

9.4 REMOVING FROM STORAGE

When removing the machine from storage, follow this procedure:

1. Remove the tarp, if covered.
2. Install and connect the battery.
3. Review and follow the Pre-Operation Checklist.
4. Review and follow the Service Checks in the Maintenance section.

IMPORTANT

If the machine has been stored for more than twelve months, warm the engine by running it for two to three minutes and then drain the oil. Change the oil while the oil is warm to remove any condensation. Refer to “10.4.5 Changing Engine Oil” on page 42.

10. MAINTENANCE

10.1 SAFETY

10.1.1 General Safety

1. Good maintenance is your responsibility. Poor maintenance is an invitation for trouble.
2. Follow good shop practices. Keep service area clean and dry. Be sure electrical outlets and tools are properly grounded. Use adequate light.

3.  Ensure proper ventilation. Never operate the engine in a closed building. The exhaust fumes may cause asphyxiation.



4.  Before working on this machine, shut off the engine and remove the ignition keys.

5.  Never work under equipment unless it is securely blocked.

6. 

Always use personal protection devices, such as eye, hand, and hearing protectors, when performing any service or maintenance.

7.  Where replacement parts are necessary for periodic maintenance and servicing, genuine factory replacement parts must be used to restore your equipment to the original specifications. The manufacturer will not be responsible for injuries or damages caused by use of unapproved parts and/or accessories.

8.   A fire extinguisher and first aid kit should be readily accessible while performing maintenance on this equipment.

9.  Periodically tighten all bolts, nuts, and screws and ensure all cotter pins are properly installed to ensure the unit is in safe condition.





10.  When completing a maintenance or service function, make sure all safety shields and devices are installed before placing the unit in service.

11.  Turn OFF all electrical power and tag-out or lock-out the power source before performing any electrical test or before connecting or disconnecting valve coils or other electrical loads.

12.  Never operate or test any function of the equipment when people are in an area of a potential crush hazard.

13. Disconnect all electronic device cables from the seed tender before performing any arc welding repair. Damage from high currents may cause internal electronic device damage.

10.1.2 Lock-Out or Tag-Out Safety

1.   Establish a formal Lock-Out or Tag-Out program for your operation.
2.  Train all operators and service personnel before allowing them to work around the seed delivery system.
3.  Provide tags on the machine and a sign-up sheet to record tag-out details.

10.2 LUBRICATION

Use “10.15 Service Record Chart” on page 52 in the Maintenance section to keep a record of all scheduled maintenance.

1. Use an SAE multi-purpose high temperature grease or a multi-purpose lithium base grease.
2. Use only a handheld grease gun for all greasing.
3. Wipe grease fittings with a clean cloth before greasing to avoid injecting dirt and grit.
4. Replace broken zerks immediately.
5. If zerks will not take grease, remove and clean the passageway. Replace fitting, if necessary.

10.2.1 Wheel Bearings

Each axle is equipped with a grease zerk under the center dust cap of the wheel. Add grease sparingly to the wheel bearings, using only wheel bearing grease. The wheel bearings should be repacked annually. Check for excessive end play and tighten, if necessary.

IMPORTANT

Over greasing wheel bearings can cause them to overheat, resulting in damage and/or failure.





10.3 BATTERY

Inspect the battery at least once every six months and before using the seed tender at the beginning of the season. Always follow the safety instructions when servicing a battery.



10.3.1 Battery Safety

1.  Keep all sparks and flames away from batteries, as gas given off by electrolyte is explosive.
2.  Avoid contact with battery electrolyte: wash off any spilled electrolyte immediately because battery acid can cause severe chemical burns.
3.  Wear safety glasses when working near batteries.
4. Do not tip batteries more than 45 degrees to avoid electrolyte loss.

10.3.2 Battery Replacement and Maintenance Tips

- Check the batteries at least every six months for low Voltage, leakage, etc.
- Always use the correct size and type of battery. Replace old batteries with a new SP-30 Lawn and Garden battery with at least 225 CCA and 290 CA ratings.
- Do not install the battery cable to the wrong terminal. Make sure the RED cable is connected to the + (plus) terminal and the BLACK cable is connected to the – (minus) terminal.
- Remove the batteries from the seed tender if not expected to be in use for several months.
- Use recommended practices when recharging a battery.
- Remove any corrosion from the battery post using a wire brush terminal cleaner. Corrosion can also be removed using a baking soda paste and water to neutralize and remove the acid from the battery terminals
- Dispose of old batteries properly.

10.3.3 Battery Maintenance

1. Make sure the tie-down strap is connected to the frame of the battery box and in good condition (not cracked, cut, or damaged).



2. The battery is charged when the engine is operating. If the battery is not charging, check the fuse. Replace the fuse if necessary.

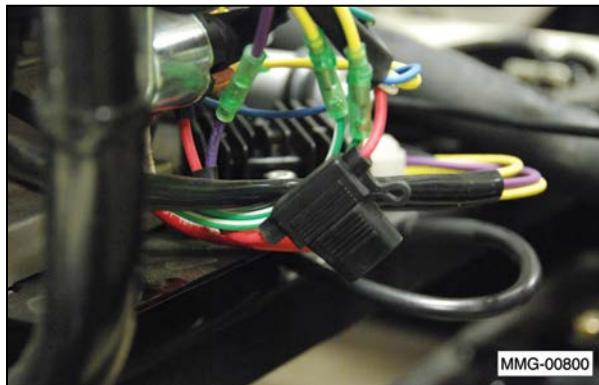





10.4 ENGINE

For any questions concerning the Kohler® engine not answered in this manual, refer to the OEM manual that was provided with the seed tender.

To contact Kohler®, refer to the OEM Literature section in this manual.

10.4.1 Refuelling Safety

1.  Handle fuel with care. It is highly flammable.
2.  Allow engine to cool for five minutes before refuelling. Clean up spilled fuel before restarting engine.
3.  Do not refuel the machine while smoking or when near open flame or sparks.
4. Fill fuel tank outdoors.
5.  Prevent fires by keeping machine clean of accumulated trash, straw, grease, and debris.

10.4.2 Approved Fuel

Use unleaded automotive gasoline for all operating conditions. The fuel tank capacity is 4.1 liters (1.1 gals).

10.4.3 Engine Oil

Use a typical SAE 10W-30 multi-viscosity motor oil for normal operating conditions. Consult your engine manual for the recommended oil in cold temperatures. The crankcase capacity is 0.60 liters (.63 US qts.).

10.4.4 Checking Engine Oil Level

Always check the engine oil level with the engine stopped and in a level position. Before removing the dipstick or the oil fill plug, clean the area around and beneath it. This will help keep foreign matter out of the engine.

Note: The engine may be equipped with two dipsticks, or an oil fill plug and a dipstick. These can be placed in either hole.

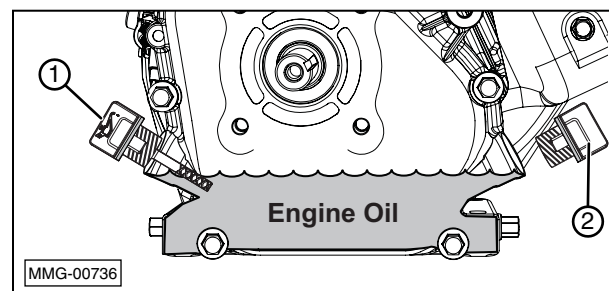

1. To check the oil level with the dipstick:
 - a. Remove dipstick (1), wipe it clean, re-insert, and rest the dipstick on the oil fill neck.

- b. Turn it counterclockwise until it drops into the lowest point of the thread leads.
Do not thread the dipstick into the oil fill neck.
 - c. If the oil level is low, add oil to the upper limit mark on the dipstick.
 - d. Reinstall the dipstick.
2. To check the oil level with the oil fill plug:
 - a. Unscrew and remove oil fill plug (2).
 - b. The oil should be up to, but not over, the point of overflowing the filler neck. If the oil level is low, add oil to this point.
 - c. Reinstall the oil fill cap.

10.4.5 Changing Engine Oil

1. Review the Operator's Manual for the engine.
2. Allow the engine to cool before changing the oil. Draining works best when the oil is warm.



BURN HAZARD
Hot engine oil can burn skin.

3. Be sure the engine key switch is in the OFF position and the fuel valve is turned OFF.
4. Place a pan under drain plug. Remove the drain plug and allow the oil to drain for ten minutes.

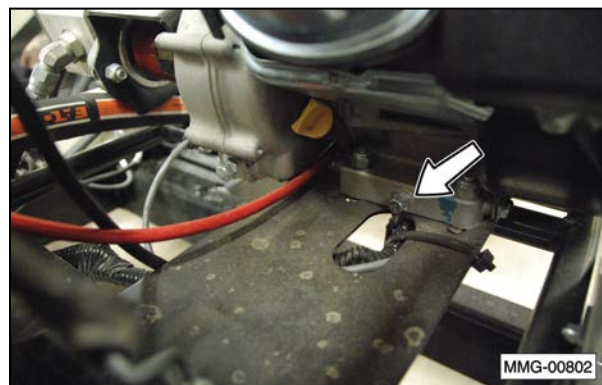

5. Reinstall the drain plug and tighten.
6. Dispose of the oil in an approved container. Follow industrial disposal regulations.

7. Fill the engine up to the point of overflowing the filler neck with SAE 10W-30 oil for general usage. If the engine is operated in more extreme conditions, refer to the OEM manual for oil recommendations.
8. Reinstall the oil fill cap/dipstick securely.



10.4.6 Checking Reduction Case Oil Level

Always check the reduction case oil level with the engine stopped and in a level position. Before removing the dipstick, clean the area around and beneath it. This will help keep foreign matter out of the reduction case.

1. Remove the dipstick, wipe it clean, re-insert, and rest the dipstick on the oil fill neck.



2. Turn it counterclockwise until it drops into the lowest point of the thread leads. Do not thread the dipstick into the oil fill neck.
3. If the oil level is low, add oil until the oil level is up to the full mark on the oil dipstick in the reduction case.
4. Reinstall dipstick securely into the reduction case.

10.4.7 Changing Reduction Case Oil

1. Allow the engine to cool before changing the oil. Draining works best when the oil is warm.

CAUTION



BURN HAZARD
Hot oil can burn skin.

2. Be sure the engine key switch is in the OFF position and the fuel valve is turned OFF.
3. Place a pan under drain plug. Remove the drain plug and allow the oil to drain for ten minutes.

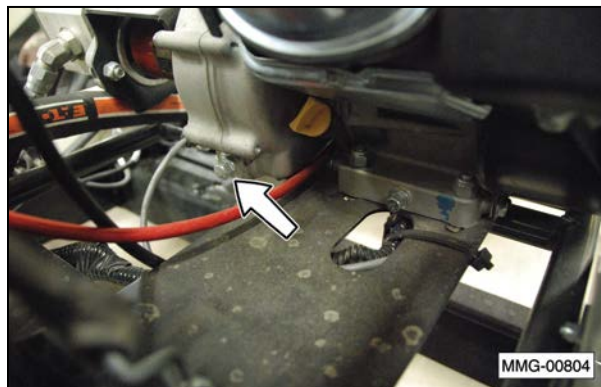

4. Reinstall the drain plug and tighten.
5. Dispose of the oil in an approved container. Follow industrial disposal regulations.
6. Fill the reduction case to the full mark on the dipstick with SAE 20W-40 or 20W-50 oil. Capacity is 0.52 US Qts. (0.5 liters).
7. Reinstall the dipstick securely into the reduction case cover.



10.4.8 Clean Air Cleaner

Check and remove any debris from the foam cover of the air cleaner daily before each use. Thoroughly clean or replace the foam cover every three months or 50 hours of operation (clean it more frequently when used in dusty conditions).



10.5 CONVEYOR ROLLERS

Check conveyor rollers for damage and replace as necessary. The conveyor trolley has four rollers to roll the trolley up and down the channels in the frame.

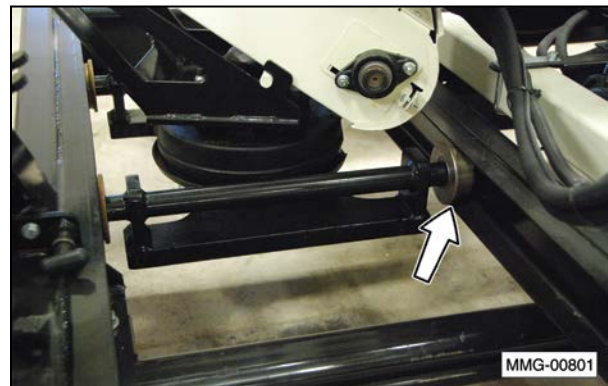

10.6 CONVEYOR ROTATION BRAKE ADJUSTMENT

1. Make sure the trolley lock plate is engaged to prevent the trolley from moving during adjustment.

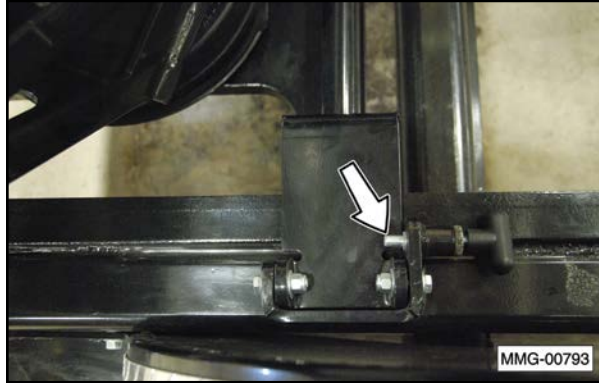

2. Turn the key to the "ON" position.
3. Activate the brake. There should be an audible click from within the hub. If there is not, make sure the battery is fully charged.

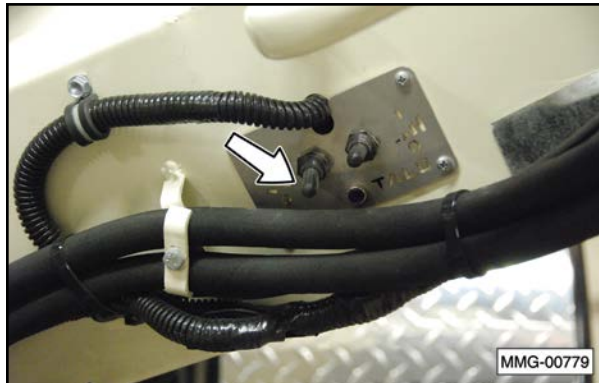

4. Remove the plugs from the adjustment slots on the bottom of the hub.

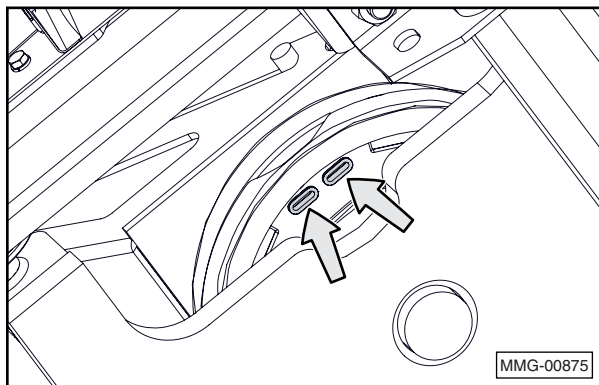

5. Insert a screwdriver through the appropriate slot and turn the brake adjuster. Clockwise rotation will tighten the brake.

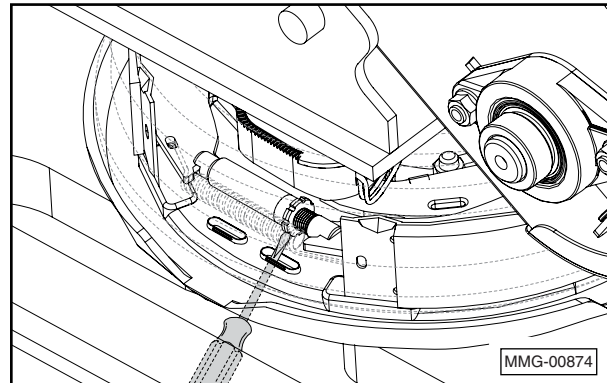

6. Make adjustments in 1/2 turn increments, and test the brake action after each adjustment.
 - a. With the brake off, the conveyor should stop within twelve to fifteen inches when pushed.
 - b. With the brake on, the conveyor should stop within five to ten inches when pushed.
 - c. It should not stop immediately, as this will result in drag when the brake is released and will make conveyor rotation more difficult.



7. Continue the adjustment until the requirements are met.
8. When satisfied with the brake action, replace the plugs in the adjustment access slots and turn the key off.

10.7 CONVEYOR REMOVAL

1. Remove the transport lock and rotate the conveyor to a convenient position.

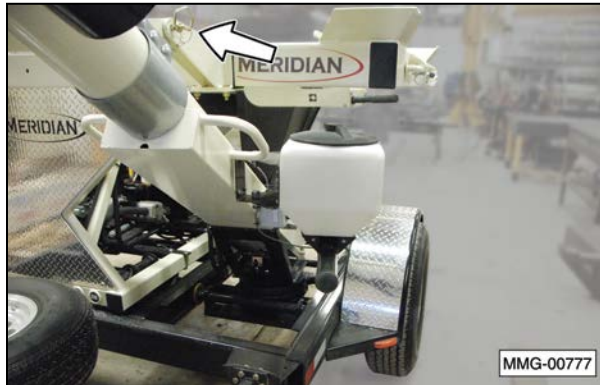

2. Lift the trolley lock plates and roll the trolley away from the slide gates.



3. Attach a suitable lifting device to the lifting point on the conveyor tube.



4. Disconnect the hydraulic lines from the motor. Have a container ready to catch any excess oil that drains from the lines.
5. Remove retaining pin (1) and withdraw lock pin (2).



6. Slide the conveyor out and set in a safe location. Protect the hydraulic fittings from damage and contamination.

10.8 CONVEYOR INSTALLATION

1. Attach a suitable lifting device to the lifting point on the conveyor tube. Slide the conveyor into the carriage. Make sure hooks (3) on the carriage engage rod (4) on the conveyor.

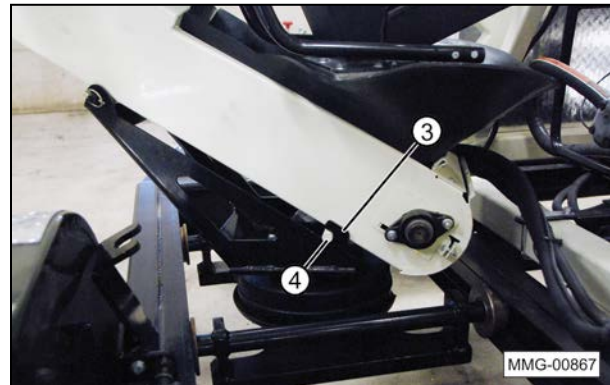

2. Insert the lock pin and its retaining pin.
3. Connect the hydraulic lines to the motor.
4. Detach the lifting device.
5. Start the engine and run the conveyor briefly. Check the hydraulic connections for leaks, and check the hydraulic oil level. Add oil as needed.

- Engage the trolley lock plates and the transport lock before transporting the tender.

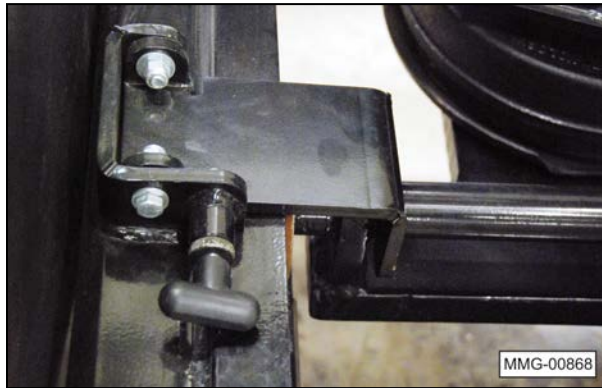

If the conveyor or auger becomes plugged, follow this procedure:

- Close the slide gate.
- Position the conveyor or auger with easy access to both ends.
- Stop the engine and remove the ignition key. Place a lock-out tag on the control box to prevent accidental starting of the conveyor or auger.
- Open the lower access door at the bottom of the conveyor and remove any excess seed or obstruction. If equipped with an auger, remove any excess seed or obstruction through the opening in the top of the auger tube.





10.9 UNPLUGGING

IMPORTANT

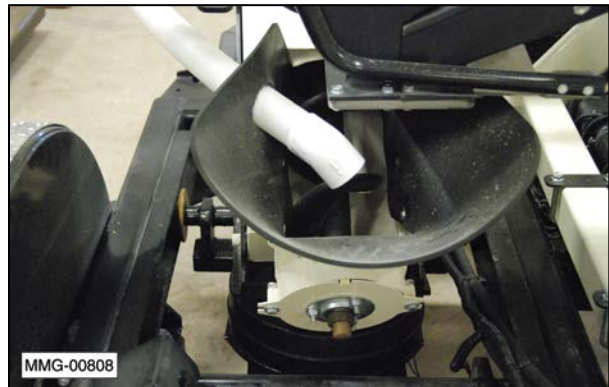
Do not operate the conveyor or auger when it is plugged with excess seed or is hindered from moving by a foreign object. Continued operation can cause damage to the conveyor or result in a broken conveyor belt.

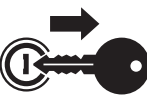

⚠ WARNING	
ENTANGLEMENT HAZARD	
  	<p>Avoid serious injury or death:</p> <ul style="list-style-type: none"> • Do not operate with access door open. • Do not place hands or fingers near rotating or moving parts. • Do not operate without guard. • Stop engine, remove ignition key, and wait for moving parts to stop before performing any work on unit.
19936	

- Close and secure the lower access door.

- Also check the delivery hood for blockage and remove any obstructions.

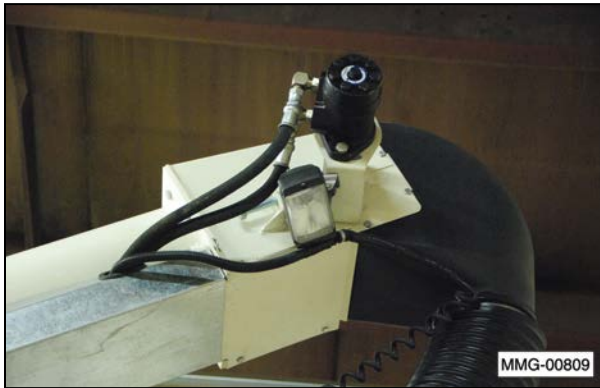

- In an extreme case it may be necessary to remove the galvanized belt guards and/or the belt itself.

10.10 CONVEYOR TUBE

10.10.1 Belt Tension Adjustment



- Loosen the locknut on each side of the belt tension mechanism.
- Tighten the two adjusting bolts equally to 23 ft-lbs. While holding the adjusting bolt in place, retighten both locking nuts.
- Start the conveyor and make sure the belt is tracking in the center of the drive drum. If the belt is not tracking properly, use the Belt Tracking Adjustment procedure to correct the problem.

IMPORTANT

The idler drum at the bottom of the conveyor must be square (drive shaft must be equal distance from end of unit) for the belt to track properly.

10.10.2 Belt Tracking Adjustment



- Loosen the locking nuts on the two adjusting bolts.
- Tighten or loosen the bolts on either side of the discharge hood to correct the tracking problem.
- Using a wrench, hold the adjusting bolt in place while tightening the locking nut against the housing. Repeat this procedure for the other adjusting bolt.
- Start the conveyor and make sure the belt is tracking in the center of the drive drum. Readjust, if needed.

10.10.3 Belt Replacement

If the belt is unbroken, it may be possible to use the old belt to thread the new belt into the delivery tube.

- Position the conveyor with easy access to both ends.
- Open the clean out door.



3. Position the idler drum adjusting bolts to their loosest position.



4. If the old belt can be used to install the new belt, continue with this step; if not, continue to Step 5.
 - a. Disconnect the two ends of the conveyor belt. Attach the replacement belt to the end of the old conveyor belt.



- b. Slowly pull the old belt out of the delivery tube and thread the new one into position.
 - c. Disconnect the old belt and connect the ends of the new belt together.
5. If the old belt cannot be used:
 - a. Remove the discharge hood and lower the galvanized belt guards.



- b. Install the new belt and connect the two ends together.

6. Tighten the two drive drum adjusting bolts equally to 23 ft-lbs. While holding the adjusting bolt in place, retighten both locking nuts.
7. Start the conveyor to make sure the belt is tracking properly. If the belt is not tracking properly, use the Belt Tracking Adjustment procedure to correct the problem.
8. Recheck the tension and alignment of the belt frequently during the first ten hours of operation, and adjust as needed. Then resume regular maintenance.

Note: Typically, a belt will seat itself during the first ten hours of operation and then require less or no adjustment.

10.11 HYDRAULIC SYSTEM

The conveyor or auger is driven by a hydraulic motor. The motor is powered by a hydraulic pump driven by the engine from the reduction case.

10.11.1 Hydraulic Oil Change



An oil and filter change is recommended annually or every 400 hours of operation using an AW HVI Hydraulic ISO 32 oil.

IMPORTANT

Never run the hydraulic pump unless the hydraulic oil tank is full.

1. Place a waste oil container under the tank drain port. The hydraulic tank holds 2.8 gallons (10.6 liters) of oil.
2. Drain the hydraulic tank by removing the drain plug from the tank. Allow the tank to drain completely.

3. Remove and replace the oil filter. Apply a thin coat of oil to the rubber seal of the new oil filter. Hand-tighten only.
4. Reinstall the drain plug.
5. Fill the tank to the bottom of the filler neck with 2.8 gallons of AW HVI Hydraulic ISO 32 oil. Replace the cap.
6. Start the engine and run the conveyor briefly.
7. Recheck the oil level in the tank and add as needed to bring the oil level to the bottom of the filler neck.

10.11.2 Hydraulic Pump Coupling

Changing the pump coupling does not require the hydraulic tank to be drained. If the pump must be disconnected, drain the hydraulic tank and be prepared to catch any oil that remains in the two hydraulic hoses.

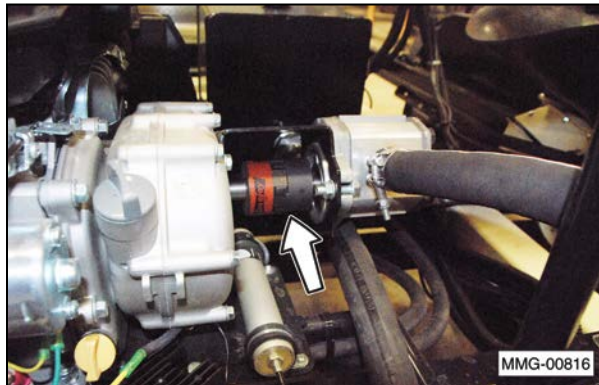

1. Remove the two pump mounting bolts.
2. Pull the pump away from the adapter to separate the coupling halves.
3. Loosen the setscrews in each coupling half and remove the old couplings. Install new couplings on the engine shaft and the pump shaft. When completely assembled, the shaft length in each coupling half should be the same. Tighten the pump end setscrews to 78 to 87 lb-in. Do not tighten the engine shaft coupling at this time.
4. Place the urethane spider in the pump coupling. Align and install the pump and pump coupling.
5. Tighten the pump bolts to a "Grade 5" bolt torque for that size of bolt. Refer to "4.2 Bolt Specifications" on page 21.

6. Slide the engine coupling against the other coupling half and tighten the setscrew.
7. If the adapter plate was removed, tighten the four retaining bolts to "Grade 5" bolt torque for that size of bolt.

10.11.3 Hydraulic Motor Coupling

The conveyor or auger is driven by a hydraulic motor mounted on the discharge end.



Changing the motor coupling does not require the hydraulic tank to be drained. If the motor must be disconnected, drain the hydraulic tank and be prepared to catch any oil that remains in the two hydraulic hoses.

1. Remove the two motor mounting bolts.
2. Pull the motor away from the mounting plate to separate the coupling halves.
3. Loosen the setscrews in each coupling half and remove the old couplings. Install new couplings on the motor shaft and the auger or conveyor shaft. When completely assembled, the shaft length in each coupling half should be the same. Tighten the motor end setscrews to 78 to 87 lb-in. Do not tighten the auger or conveyor shaft coupling at this time.

- Place the urethane spider in the motor coupling. Align and install the motor and motor coupling.
- Tighten the motor mounting bolts to a “Grade 5” bolt torque for that size of bolt. Refer to “4.2 Bolt Specifications” on page 21.
- Slide the drive coupling against the other coupling half and tighten the setscrew.
- If the adapter plate was removed, tighten the four retaining bolts to “Grade 5” bolt torque for that size of bolt. Refer to “4.2 Bolt Specifications” on page 21.

- Plug the trailer into the tow vehicle. The yellow “Charging” light should be ON. Test the system by pulling the pin out of the break-away switch. The battery will activate the brakes. (**Note:** Do not use this kit as a parking brake). The battery should be charged and tested prior to each trailer outing.

10.12 TRAILER BREAK-AWAY SYSTEM

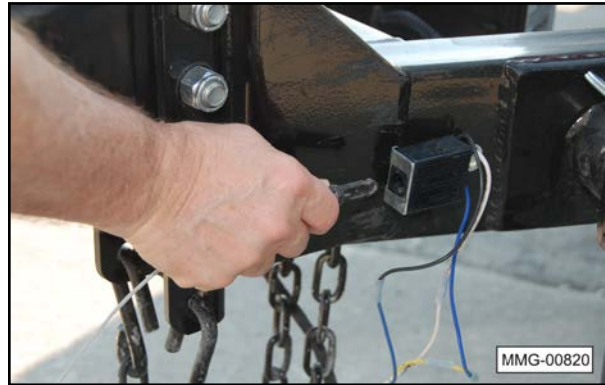

10.12.2 Charging Battery

The battery in the break-away system is rechargeable. If the battery will not hold a charge, replace the battery.

10.12.3 Replacing Battery

The battery in the break-away system is replaceable. If the battery will not hold a charge, replace the battery. Contact the OEM supplier for a replacement battery.

10.12.1 Testing the Battery

- Disconnect the trailer plug from the tow vehicle; otherwise, you are testing the tow vehicle’s battery.
- Press the green TEST button on the control box located inside the frame of the trailer. The green indicator light should illuminate if the battery is fully charged. If the yellow or red indicator lights illuminate, the unit’s battery should be charged before towing the trailer.

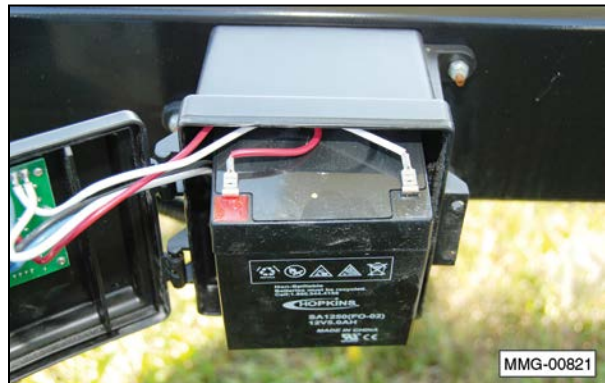

IMPORTANT

If the battery is weak or dead (red indicator, even after charging), as indicated by the indicator light, the battery must be replaced.

10.13 WHEEL BOLT TORQUE REQUIREMENTS



1. Initially check the wheel bolt torque at 10, 25, and 50 miles and after each wheel removal.

Note: Torque wrenches are the best method to ensure the proper amount of torque is being applied to a wheel nut.

CAUTION



EXPLOSIVE FORCE HAZARD
To prevent injury due to possible dangerous separation of wheels from the axle, the wheel nuts must be maintained at the proper torque levels. Properly tightened wheel nuts prevent loose wheels and broken studs.

2. Tighten the wheel nuts in three stages.
 - First stage: 20 to 25 foot pounds.
 - Second stage: 50 to 60 foot pounds.
 - Third stage: 90 to 120 foot pounds.
3. Tighten the wheel nuts in a clockwise, cross-axle alternating pattern.

10.14 AXLE BOLTS, FRAME HOLD-DOWN BOLTS, AND TRAILER HITCH BOLTS

Check the torque on the axle/frame bolts at least once per year. Tighten the bolts to 290 ft-lbs.

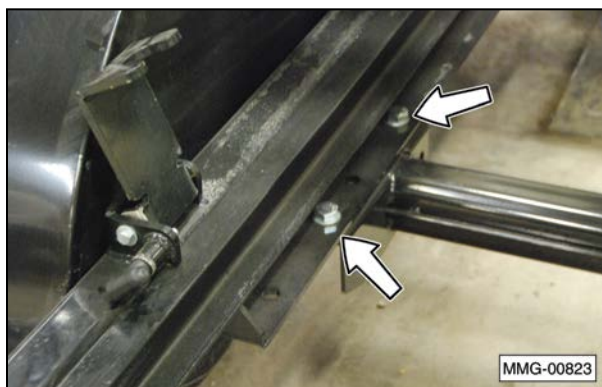

Additional holes are provided in the frame for relocating the axles.

- a. On triple axle units, the axles can be moved forward or rearward on the frame 12" either way.
- b. On double axle units, the axles can be moved 6" rearward if desired.
- c. Axle location cannot be changed on single axle units.

Check the torque on the frame hold-down bolts at least once per year. Tighten the bolts to 40 ft-lbs.

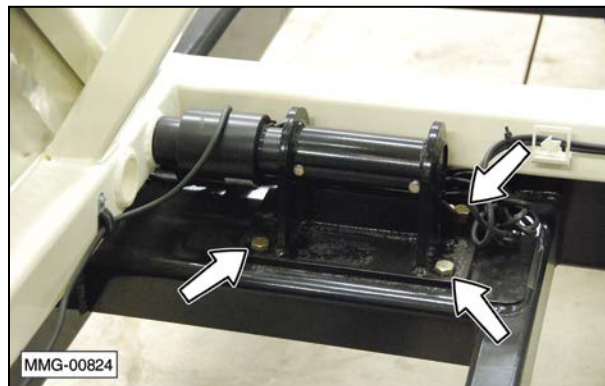

The front hitch section of the seed tender is bolted to the trailer frame. This design allows the same trailer to use either a standard hitch assembly or a gooseneck trailer hitch if this option is available.

Check the torque on the trailer hitch bolts at least once per year. Tighten the bolts to 45 ft-lbs.

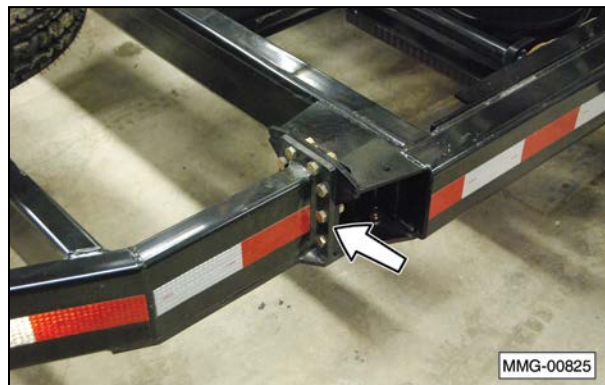

10.15 SERVICE RECORD CHART

The chart on the following page should be copied and filled out as maintenance is performed on the machine. Refer to the Lubrication, Maintenance, and Service sections for additional instructions.

Date																			
Serviced by																			
8 hours or daily																			
Check Engine Oil Level																			
Check Reduction Case Oil Level																			
Check Hydraulic Oil Level																			
Test Break-Away Brake System																			
Inspect Tires																			
50 Hours or Weekly																			
Check Tire Pressure																			
50 Hours																			
Change Reduction Case Oil*																			
Clean Engine Air Intake Filter																			
100 Hours																			
Change Engine Oil*																			
200 Hours or Semi/Annual																			
Adjust Brakes																			
Inspect Brake Magnets																			
Battery - Make sure strap is securely holding battery onto frame, check electrolyte levels in the cells, and clean terminals to remove any dirt or corrosion.																			
400 hours or annually																			
Change Hydraulic Oil																			
Check Wheel Bolt Torque (90-120 ft-lbs.)																			
Check Frame Hold-Down Bolts (40 ft-lbs.)																			
Check Trailer Hitch Bolts (45 ft-lbs.)																			
Check Axle/Frame Bolts (290 ft-lbs.)																			
Inspect Brake Lining Wear and Brake Wiring																			
Repack Wheel Bearings and Check Hub for Wear																			
Inspect Axle Grease Seal																			
Inspect all electrical wiring connections for looseness or corrosion. Tighten and/or seal, as necessary.																			
Thoroughly Clean Machine																			

*As per OEM instructions.

10.16 SERVICE CHECKS

10.16.1 8 Hours or Daily

WARNING



FIRE HAZARD

Gasoline is a highly combustible fuel. Improper use, handling, or storage of gasoline can be dangerous. Never touch or fill a hot engine. **DO NOT** fill the engine's fuel tank near an open flame while smoking or while engine is running. **DO NOT** fill tank in an enclosed area with poor ventilation. **Wipe up spills immediately.**

1. Check engine oil level (1) and fill, as needed. Refer to "10.4.4 Checking Engine Oil Level" on page 41.
2. Check reduction case oil level (2) and fill, as needed. Refer to "10.4.6 Checking Reduction Case Oil Level" on page 42.

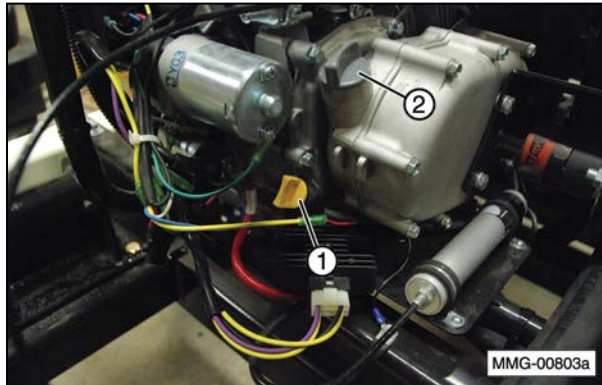

3. Check Hydraulic oil level and fill, as needed. Refer to "10.11.1 Hydraulic Oil Change" on page 48.

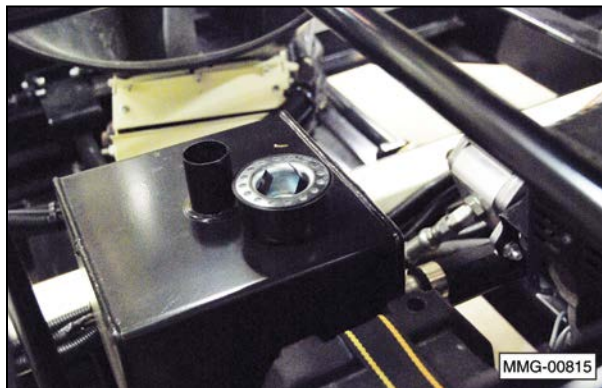

4. Test trailer break-away system. Refer to "10.12.1 Testing the Battery" on page 50.
5. Check tires for damage. Initially check wheel bolt torque (90-120 ft-lbs.) at 10, 25, and 50 miles.

10.16.2 50 Hours

1. Clean or replace the foam filter element. Replace the paper air filter, as required. Refer to "10.4.8 Clean Air Cleaner" on page 43.



2. Change the reduction case oil. Refer to "10.4.7 Changing Reduction Case Oil" on page 43.

10.16.3 50 Hours or Weekly

1. Check the tire pressure. Inflate the tires to the recommended pressure stated on the tire.

10.16.4 100 Hours or Monthly

1. Change the engine oil. Refer to "10.4.5 Changing Engine Oil" on page 42.

10.16.5 200 Hours or Semi-Annually

1. Adjust the trailer brakes.
2. Inspect the brake magnets.
3. Clean the battery terminals to remove any dirt or corrosion, check electrolyte levels in the cells, and make sure the strap holding the battery box onto the frame is secure. Refer to "10.3.3 Battery Maintenance" on page 41.

10.16.6 400 Hours or Annually

1. Check the trailer hitch bolts (45 ft-lbs.).
2. Check the axle/frame bolts (290 ft-lbs.).
3. Check the frame and trailer hold-down bolts (40 ft-lbs.).
4. Check wheel bolt torque (90-120 ft-lbs.).
5. Repack the wheel bearings and check for excessive end play in the bearings. Refer to "10.2.1 Wheel Bearings" on page 40.
6. Check the tires for wear, and replace if needed.
7. Thoroughly clean the seed tender.

10.17 AXLE MAINTENANCE

10.17.1 First 200 Miles

1. Adjust brakes. Refer to OEM manual for procedure.

10.17.2 3,000 Miles or 3 Months

1. Adjust brakes. Refer to OEM manual for procedure.
2. Check torque on wheel nuts. Refer to the section in this manual.
3. Inspect tires for wear. Refer to OEM manual for procedure.

10.17.3 6,000 Miles or 6 Months

1. Inspect brake magnets for wear. Refer to OEM manual for procedure.
2. Inspect suspension parts for wear. Refer to OEM manual for procedure.

10.17.4 12,000 Miles or 12 Months

1. Inspect brake lining wear, and inspect brake wiring for damage. Refer to OEM manual for procedure.
2. Grease the wheel bearings and check the hub for wear. Refer to OEM manual for procedure.
3. Inspect grease seal for leakage. Refer to OEM manual for procedure.

10.18 TIRES

Check the tires for normal and/or abnormal tire wear. Replace tires that are damaged or worn beyond normal tread life. Refer to the axle OEM manual for a Tire Wear Diagnostic Chart.

Replace the tires with Meridian part number 18131 or an equivalent tire:
3T235/80R16
TR643
Load Range E
For Trailer Service Only

10.19 WELDING REPAIRS



Repair welding must be done with care and with procedures that may be beyond the capabilities of the ordinary welder.

Before performing any type of welding repair to the seed tender, contact Meridian for approval.

WARNING



PERSONAL INJURY HAZARD

Repairs or modifications to the trailer, trailer tongue, or trailer hitch can result in serious injury or death should these repairs fail.

IMPORTANT NOTICE

Anyone performing a welding repair should be certified in accordance to the American Welding Society (AWS) standards.

11. TROUBLESHOOTING

11.1 TROUBLESHOOTING CHART

PROBLEM	CAUSE	SOLUTION
Engine will not start.	No fuel.	Fill the fuel tank.
	Low engine oil.	Fill the crankcase with oil.
	Cold engine.	Close choke.
	Ignition key switch off.	Turn ignition key switch on.
	Battery dead.	Recharge or replace battery.
	Engine problem.	Refer to engine manual.
Conveyor will not start.	Not rotating.	Start engine and increase speed above 1400 RPM.
	Hydraulic pump coupling or conveyor motor coupling.	Repair or replace. Refer to "10.11 Hydraulic System" on page 48.
	Failed centrifugal clutch.	Replace clutch.
Electrical functions are not working properly.	Battery cable or battery.	Check battery cable and make sure battery is fully charged.
	Improper ground.	Check for proper grounding of electrical circuit.
Remote throttle doesn't work.	No input power.	Check charge of battery. Recharge or replace, as required.
		Check connections in the remote throttle harness. Be sure connectors are clean and terminals are firmly pushed together.

12. OEM LITERATURE

OEM literature can be stored on the seed tender using the document storage tube.



12.2 AXLE

For any questions concerning the Axis Products axle, refer to the OEM manual that was provided with the seed tender. An Owner's Manual and parts listing is provided with the seed tender.

Additional information can be obtained from:
Axis Products, Inc.
3403 Reedy Drive
Elkhart, IN 46514
Phone: (574) 266-8282

12.1 KOHLER® ENGINE

For any questions concerning the Kohler® engine, refer to the OEM manual that was provided with the seed tender.

KOHLER Command PRO
CH260, CH270, CH395, CH440
Owner's Manual

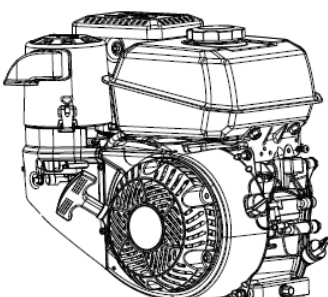

EN
DA
DE
ESE
ESS
FRC
FRF
HR
ID
IT
KO
NL
PL
PT
RO
RU
SL
ZH

IMPORTANT: Read all safety precautions and instructions carefully before operating equipment. Refer to operating instruction of equipment that this engine powers.
Ensure engine is stopped and level before performing any maintenance or service.
Warranty coverage as outlined in the warranty card and on KohlerEngines.com. Please review carefully as it provides you specific rights and obligations.
To maintain compliance with applicable emission regulations, exhaust system backpressure may not exceed limits which can be found on KohlerEngines.com. Search by Model No., select Read More, then select Specs tab.

Record engine information to reference when ordering parts or obtaining warranty coverage.

Engine Model _____
Specification _____
Serial Number _____
Purchase Date _____

17 590 12 Rev. -- KohlerEngines.com

Additional information can be obtained from:

Kohler Co.,
Kohler, WI 53044
(920) 457-4441
KohlerEngines.com

13. WARRANTY

13.1 WARRANTY STATEMENT

Limited Materials and Workmanship Warranty For Bulk Seed Tenders

Meridian Manufacturing Group (hereinafter referred to as the Manufacturer) hereby warrants the Bulk Seed Tender(s) sold by it to be free from any defect in material or workmanship under normal use and service for a period of one (1) year from the date of shipment. The Manufacturer's obligation under this warranty shall be limited to the repair or replacement only, FOB the original point of shipment, of any defective parts or portions of the seed tender or accessories manufactured by Meridian. Any warranty claim must be reported to the Manufacturer within one (1) year from the date of shipment.

THIS WARRANTY IS SUBJECT TO THE FOLLOWING LIMITATIONS, PROVISIONS AND CONDITIONS:

1. This warranty does not apply:
 - a) To any product sold by the Manufacturer where it is used in areas exposed to corrosive or aggressive conditions including salt water, acids, alkaloid, ash, cement dust, animal waste or other corrosive chemicals from either inside or outside the bin.
 - b) For failures or defects arising out of damage during shipment or during storage on site.
 - c) To materials replaced or repaired under this warranty except to the extent of the remainder of the applicable warranty.
 - d) To damage resulting from misuse, negligence, accident or improper site preparation by others.
 - e) If the product has been altered or modified by others.
 - f) If in the case of coating failures the failure is the result of damage, lack of proper maintenance or failure to remove road salt or other contaminants that may have come in contact with the bin surface.
 - g) To loss of time, inconvenience, loss of material, down time or any other consequential damage.
 - h) For a function that is different than original designed intent.
2. The obligation of the Manufacturer under this warranty shall not arise unless the Manufacturer is notified and this warranty is presented together with a written statement specifying the claim or defect within thirty (30) days after the failure is first detected or made known to the owner and within one (1) year from the shipment date. The Manufacturer in its sole discretion shall determine if the claim is valid and whether correction of the defect or failure shall be made by repair or replacement of the materials.
3. The coating warranty is based on the manufacturer's performance specification for Polyester Powder finishes and does not include repair of minor blemishes or rusting that is normally part of the general maintenance of the seed tender. This warranty does not cover excessive wear on interior coatings. See attachment for full Performance Specification details on Polyester Powder Finishes.
4. The obligation of the Manufacturer hereunder extends only to the original owner and to the Meridian dealer to whom the materials may have been initially sold. This warranty shall not be subject to any assignment or transfer without the written consent of the Manufacturer.
5. The customer shall acknowledge that it has made its own independent decision to approve the use of the supplied materials and also the specific fabrication and construction procedures utilized to complete the seed tender, and has satisfied itself as to the suitability of these products for this particular application.
6. The foregoing sets forth the only warranties applicable to said materials and said warranties are given expressly and in lieu of all other warranties, expressed or implied, statutory or otherwise, of merchantability or fitness for a particular purpose and all warranties which exceed or differ from said warranties herein are disclaimed by the Manufacturer.
7. The owners sole and exclusive remedy against the Manufacturer shall be limited to the applicable warranty set forth herein and the endorsements, if any, issued together with this document and no other remedy (including but not limited to the recovery of assembly or disassembly costs, shipping costs, direct, incidental, special, indirect or consequential damages for lost profits, lost sales, injury to person or property or any other loss, whether arising from breach of contract, breach of warranty, tort, including negligence, strict liability or otherwise) shall be available to the owner or Meridian Dealer or any other person or entities whether by direct action or for contribution or indemnity or otherwise.
8. The financial obligation of the Manufacturer under this warranty shall be limited to the repair or replacement of the product as originally supplied and in no event shall exceed the original cost of the product supplied.
9. The Manufacturer shall not have any obligation under any warranty herein until all accounts for materials, installation and erection of the said product thereof and for labor and other work performed by the Manufacturer or its dealers have been paid in full by the owner.

Warranty Claim Procedure

1. Registering product with Meridian Manufacturing.
2. Contact the dealer unit was purchased from upon discovery of any defects.
3. A completed warranty claim form submitted by dealer to Meridian warranty representative for review and course of action.
4. Warranty repair work will only be performed by Meridian, the dealer or an approved representative. No warranty work completed prior to approval. Failure to follow procedure may affect any or all reimbursement.
5. Claims will be adjudicated at the sole discretion of the manufacturer and in accordance with the terms and conditions of the applicable limited warranty.
6. A complete list of warranty procedures can be procured from the Warranty Department or found in your owner's manual.

Effective July 1, 2009

14. PARTS

The following pages contain a list of serviceable parts for the Titan SR2 Seed Tender unit.

Parts are available from your authorized Dealer Parts Department.

14.1 TITAN SR2 SEED TENDER FRAME 32384

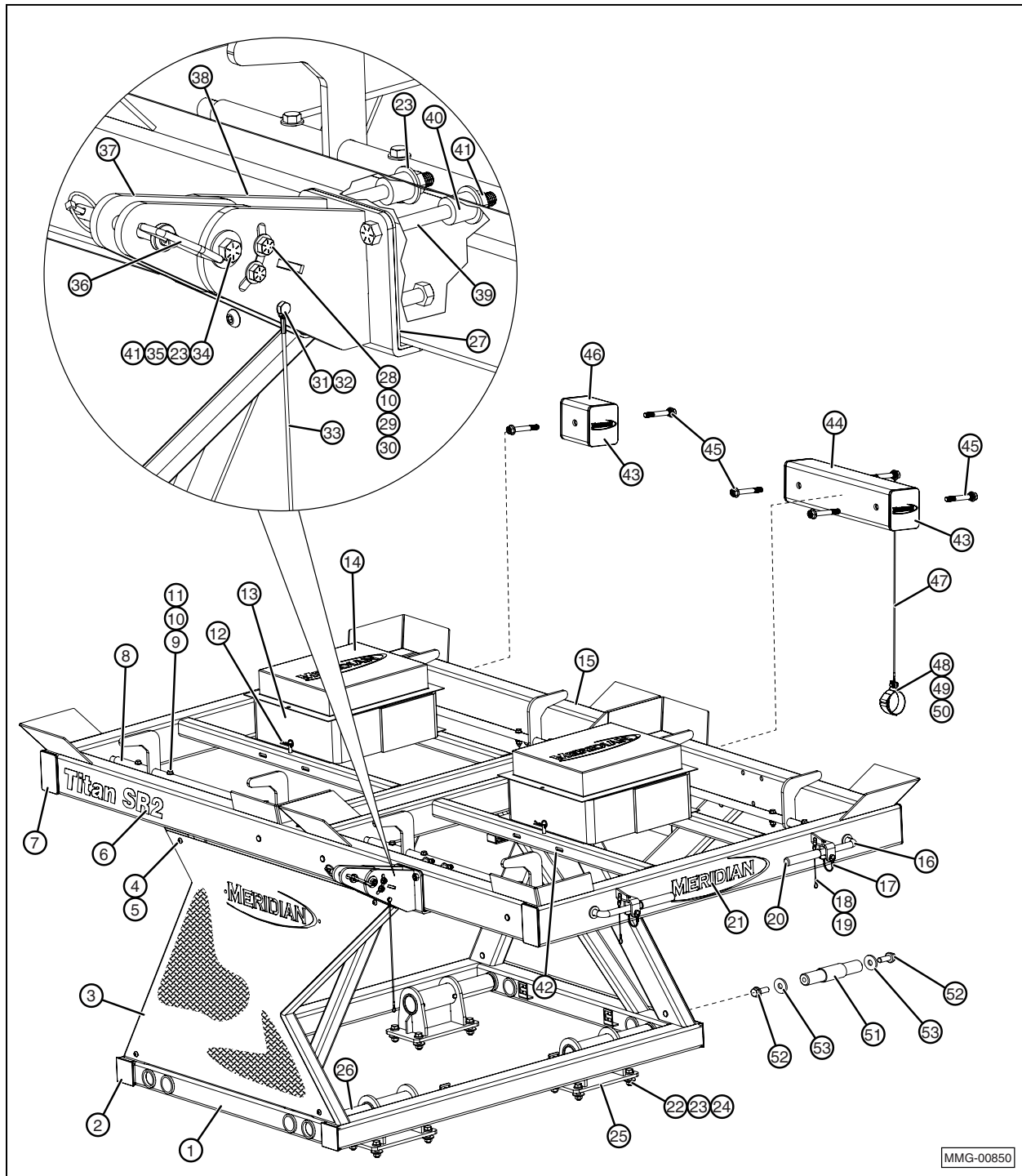

MMG-00850

1	1	32383	Frame, Weldment
2	4	18000	Plug
3	1	20787	Plate, Meridian, Front
4	8	17239	Screw
5	8	17230	Insert, Threaded
6	2	17227	Decal, Titan SR2
7	4	18420	Plug
8	4	32379	Tube, Latch
9	8	19618	Bolt, Hex, 3/8-16 x 1-3/4"
10	16	19068	Washer, Flat, 3/8"
11	8	19347	Nut, Lock, Nylon, 3/8-16
12	4	19594	Pin, Hairpin Cotter
13	2	22147	Seal, Box Top Deck, Titans
14	2	14020	Lid, Plastic
15	1	20786	Plate, Meridian, Rear
16	8	21592	Rod, Handle
17	2	23573	Pin
18	2	19089	Rivet
19	2	—	Tether
20	2	17237	Grip
21	2	17228	Decal, Meridian
22	16	19575	Bolt, Hex Flange, 1/2-13 x 1-1/2"
23	21	18487	Washer, Flat, 1/2"
24	16	19595	Nut, Hex, Flanged, 1/2-13
25	4	30458	Mount, Weldment
26	4	23933	Pin, Mount
27	1	17232	Pad
28	2	17240	Bolt, Hex 3/8-16 x 3-1/2"

29	4	19191	Nut, Hex, 3/8-16
30	2	17241	Nut, Lock, 3/8-16
31	1	19301	Bolt, Hex 1/4-20 x 1"
32	1	19128	Nut, Lock, 1/4-20
33	1	14053	Tether
34	1	17231	Bolt, Hex, 1/2-13 x 3-1/2"
35	1	19115	Nut, Hex, Lock, 1/2-13
36	1	19748	Pin
37	2	20788	Plate
38	1	32458	Bracket, Weldment
39	3	17235	Bolt, Hex, 1/2-13 x 5-1/2"
40	3	17233	Spacer
41	1	17234	Nut, Hex, Lock, 1/2-13
42	20	17256	Plug
43	*	17252	Plug
44	*	20785	Tube
45	*	17238	Bolt, Hex, Flange, 1/2-13 x 4", Grade 8
46	*	12446	Tube
47	1	17254	Tether
48	1	17769	Bolt, Hex, Flange, 1/4-20 x 3/4"
49	2	19307	Washer, Flat, 1/4"
50	1	19128	Nut, Hex, Lock, 1/4-20
51	*	17229	Pin, Mount
52	*	17234	Bolt, Hex, 3/4-10 x 2", Grade 8
53	*	20855	Washer, Flat, 3/4"

14.2 TITAN SR2 CONVEYOR ASSEMBLY

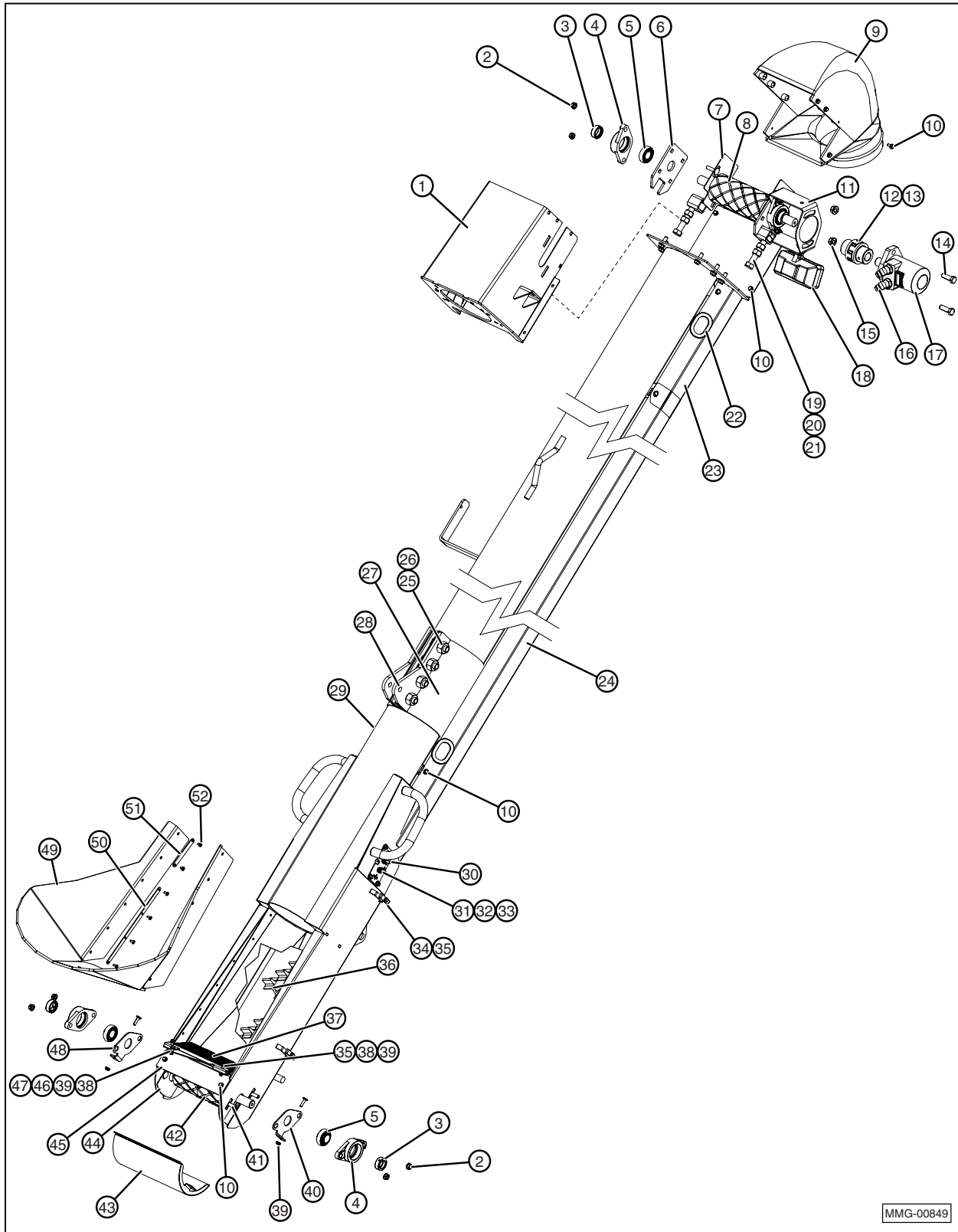

1	1	32409	Weldment, Cover
2	8	19564	Nut, Hex, Flanged, 3/8-16
3	4	21258-00C	Bearing, Collar
4	4	27040	Housing, Roller Bearing
5	4	21258	Bearing
6	2	32406	Plate, Discharge Roller Slide
7	2	20758	Plate
8	1	36200-01	Roller, Drive
9	1	17214	Hood, Discharge
10	8	—	Bolt, Hex, Flanged, 1/4-20 x 1/2"
11	1	20751	Bracket, Motor Mount
12	2	19249	Coupling, Hyd.
13	1	19291	Spider
14	2	19355	Cap Screw, 1/2-13 x 1-1/2"
15	2	19595	Nut, Hex, Flanged, 1/2-13
16	2	17999	Fitting, Hyd.
17	1	19768	Motor, Hydraulic
18	1	18188	Light, Work
19	2	19380	Bolt, Hex, 5/8-11 x 4-1/2"
20	4	19382	Nut, Hex, 5/8-11
21	2	19663	Nut, Sq., 5/8-11
22	2	14061	Grommet
23	1	20752	Guard, Belt
24	1	20747	Guard, Belt
25	4	19745	Bolt, Carriage, 3/4-10 x 3"
26	4	19652	Nut, 3/4-10
27	1	17270	Clamp, Tube

28	2	23711	Plate
29	1	32407	Weldment, Tube
30	1	14002	Switch
31	1	14058	Switch
32	1	20986	Plate, Switch
33	4	19682	Screw, Hex, Self Drilling, #10
34	6	20983	Plate
35	8	—	Bolt, Hex, Flanged, 1/4-20 x 1-1/4"
36	1	21107	Belt, 8"
37	1	17215	Brush
38	4	18485	Washer, Flat, 1/4"
39	5	19126	Nut, Hex, Flanged, 1/4-20
40	1	32405	Plate
41	8	19695	Bolt, Carriage, 3/8-16 x 1-1/4"
42	1	36201	Roller, Idler
43	1	32403	Cover
44	2	20794	Plate
45	8	20748	Plate
46	1	17769	Bolt, Flanged, 1/4-20 x 3/4"
47	1	20749	Plate
48	1	20756	Plate
49	1	20750	Hopper, Rubber
50	2	20773	Strip
51	2	20774	Strip
52	12	19129	Rivet

14.3 TITAN SR2 AUGER ASSEMBLY

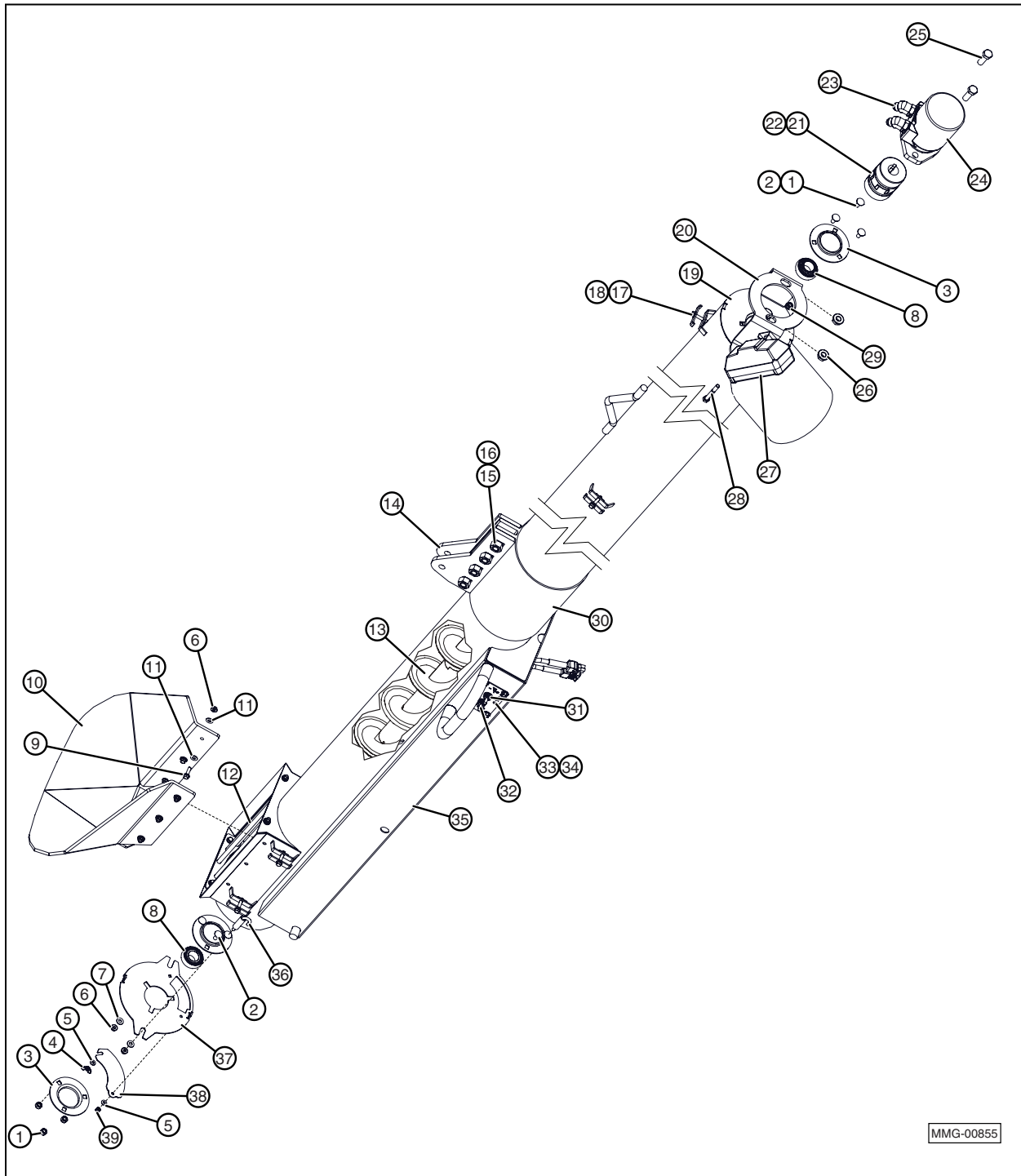

1	6	19586	Nut, Hex, Flanged, 5/16-18
2	1	19315	Bolt, Carriage, 5/16-18 x 3/4"
3	4	21259	Flange
4	1	17236	Nut, Wing, #10-32
5	4	17591	Washer, Flat, #10
6	1	19126	Nut, Hex, Flanged, 1/4-20
7	6	19307	Washer, Flat, 1/4"
8	2	21258	Bearing
9	6	—	Bolt, Hex, Flanged, 1/4-20 x 7/8"
10	1	20982	Hopper, Rubber
11	16	18485	Washer, Flat, 1/4"
12	1	32399	Guard
13	1	17280	Auger
14	2	23711	Plate
15	4	19745	Bolt, Carriage, 3/4-10 x 3"
16	4	19652	Nut, 3/4-10
17	7	20983	Plate
18	7	—	Bolt, Hex, Flanged, 1/4-20 x 1-1/4"
19	1	20980	Plate
20	1	20981	Bracket, Motor Mounting

21	2	19247	Coupling, Hyd.
22	1	19291	Spider
23	2	17999	Fitting, Hyd.
24	1	17271	Motor, Hydraulic
25	2	19355	Screw, Cap, 1/2-13 x 1-1/2"
26	2	19595	Nut, Hex, Flanged, 1/2-13
27	1	18188	Light, Work
28	2	—	Bolt, Hex, 5/16-18 x 2-1/2"
29	2	19318	Nut, Hex, Flanged, 5/16-18
30	4	17270	Clamp, Tube
31	1	14002	Switch
32	1	14058	Switch
33	1	20986	Plate, Switch
34	4	19682	Screw, Hex, Self Drilling, #10
35	1	34200	Weldment, Auger Tube
36	2	17399	J-Bolt, 1/4-20
37	1	20795	Plate
38	1	20796	Plate, Access
39	1	17722	Nut, Locking, #10-32

14.4 TITAN SR2 DELIVERY CHUTE & SLIDE GATES 32461

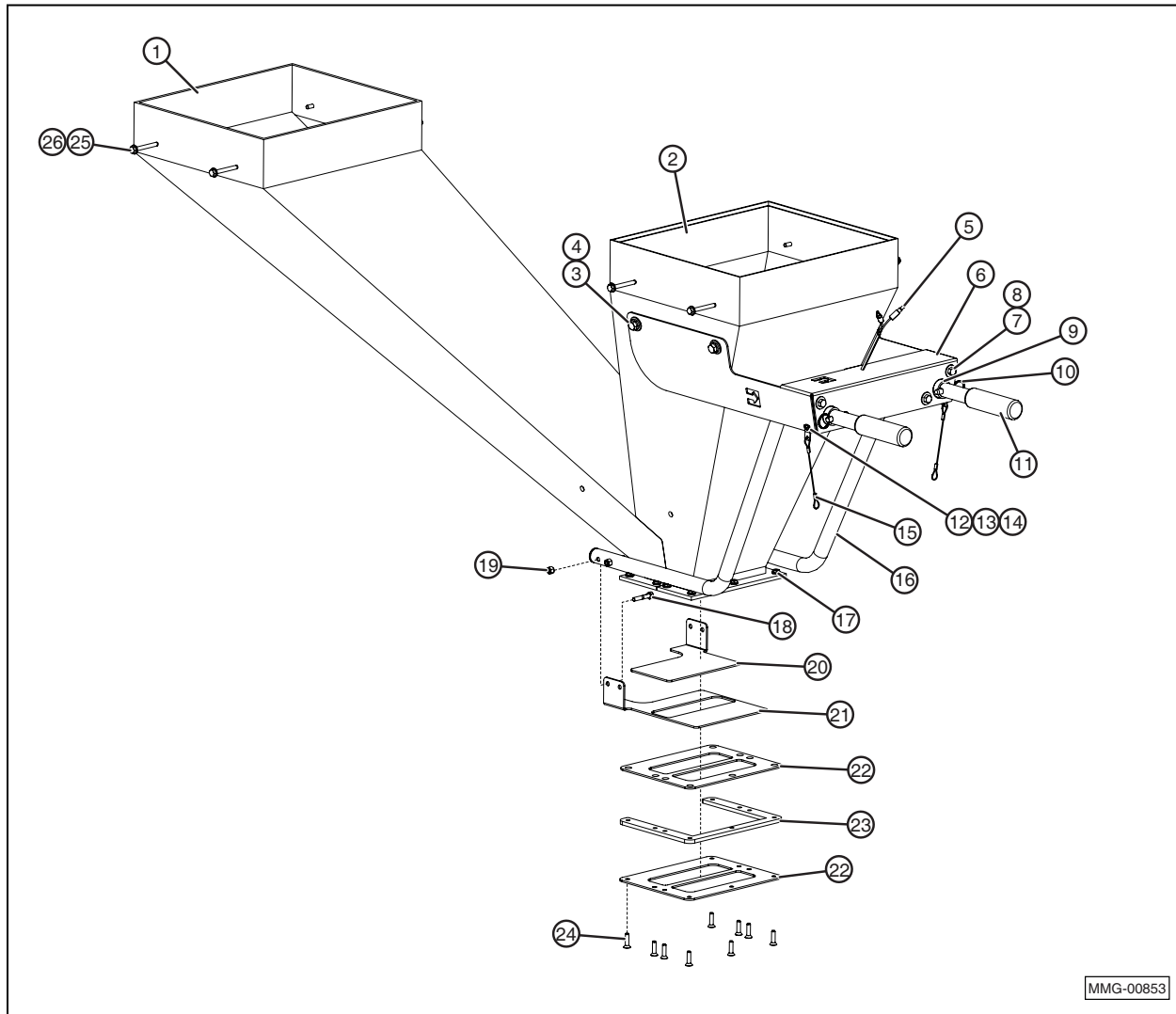

1	1	17243	Discharge Transition
2	1	17242	Discharge Transition
3	4	19577	Bolt, Hex, Flanged, 3/8-16 x 3/4"
4	4	18473	Washer, Flat, 3/8"
5	1	17221	Harness, Wire
6	1	20860	Bracket, Handle
7	4	—	Bolt, Hex, Flanged, 5/16-18 x 7/8"
8	4	19318	Nut, Hex, Flanged, 5/16-18
9	2	19404	Guide, Handle
10	2	17244	Pin, Lock
11	2	19447	Grip, Handle
12	2	21255	Screw, Cap, #10-32 x 1/2"
13	2	17591	Washer, Flat, #10

14	2	17722	Nut, Locking, #10-32
15	2	17245	Tether
16	2	17220	Handle, Gate
17	9	19126	Nut, Hex, Flanged, 1/4-20
18	4	—	Bolt, Hex, 1/4-20 x 1-1/2"
19	4	19128	Nut, Hex, Flanged, 1/4-20
20	1	20858	Slide, Gate
21	1	20859	Slide, Gate
22	2	20861	Plate
23	2	20862	Spacer
24	9	—	Screw, Machine, Countersunk, 1/4-20 x 1"
25	2	—	Bolt, Hex, 1/4-20 x 3"
26	2	19307	Washer, Flat, 1/4"

14.5 TITAN SR2 CARRIAGE ASSEMBLY

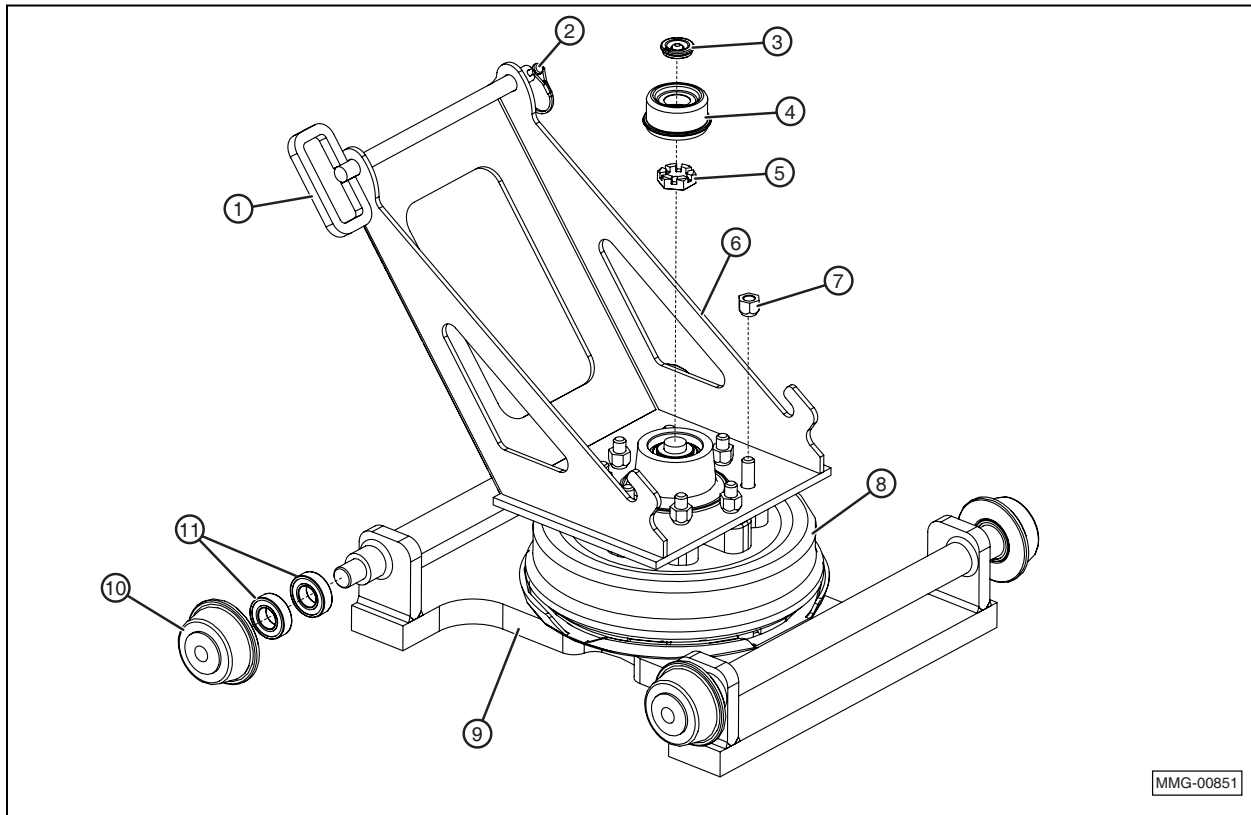

MMG-00851

1	1	30878	Pin, Retaining
2	1	19693	Pin, Locking
3	1	770963110000	Plug
4	1	770963150000	Cap
5	1	786722016140	Nut, Castle
6	1	30879	Mount, Conveyor
7	8	750730008120	Nut, Lug
8	1	17282	Hub with Brake
9	1	32455	Carriage
10	4	17283	Roller
11	8	17277	Bearing

14.6 TITAN SR2 POWER UNIT

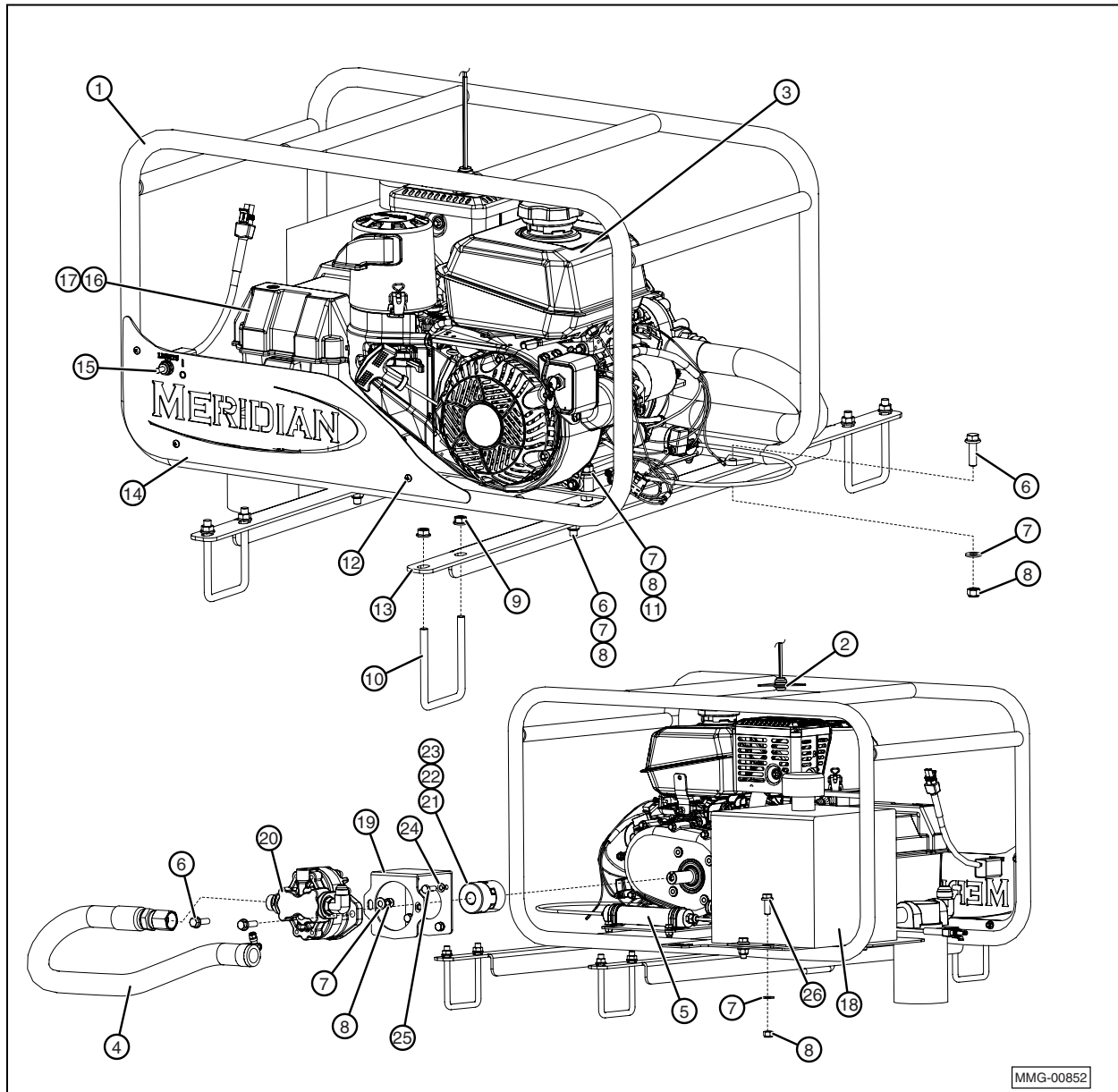

MMG-00852

1	1	32465	Mounting Frame, Power Unit
2	1	17221	Light
3	1	17278	Engine, Kohler 7 Hp Electric Start
4	1	20873	Hose, Hydraulic
5	1	17721	Actuator
6	4	18680	Bolt, Hex, 3/8-16 x 1-1/4"
7	14	19348	Washer, Flat, 3/8
8	14	19347	Nut, Lock, 3/8-16 Nylon
9	8	19564	Nut, Hex, Flanged, 3/8-16
10	4	17226	U-Bolt, 3/8-16
11	4	19626	Bolt, Hex, Flanged, 3/8-16 x 1-3/4"
12	1	21255	Screw, Round Head, #10-32 x 1/2"
13	2	20870	Angle, Mounting
14	1	20871	Plate, Meridian

15	1	14058	Switch, Light
16	1	11219	Box, Battery
17	1	21286	Battery, SP-30
18	1	17281	Tank, Hydraulic
19	1	20872	Adapter, Pump Mounting
20	1	17246	Pump, Hydraulic
21	1	17224	Coupling, Hyd., Pump
22	1	17223	Spider
23	1	17225	Coupling, Hyd., Engine
24	4	19322	Washer, Flat, 5/16"
25	4	—	Bolt, Hex, Flanged, 5/16-18 x 7/8"
26	4	19569	Bolt, Hex, Flanged, 3/8-16 x 1"

14.7 TITAN SR2 GOOSENECK HITCH ASSEMBLY

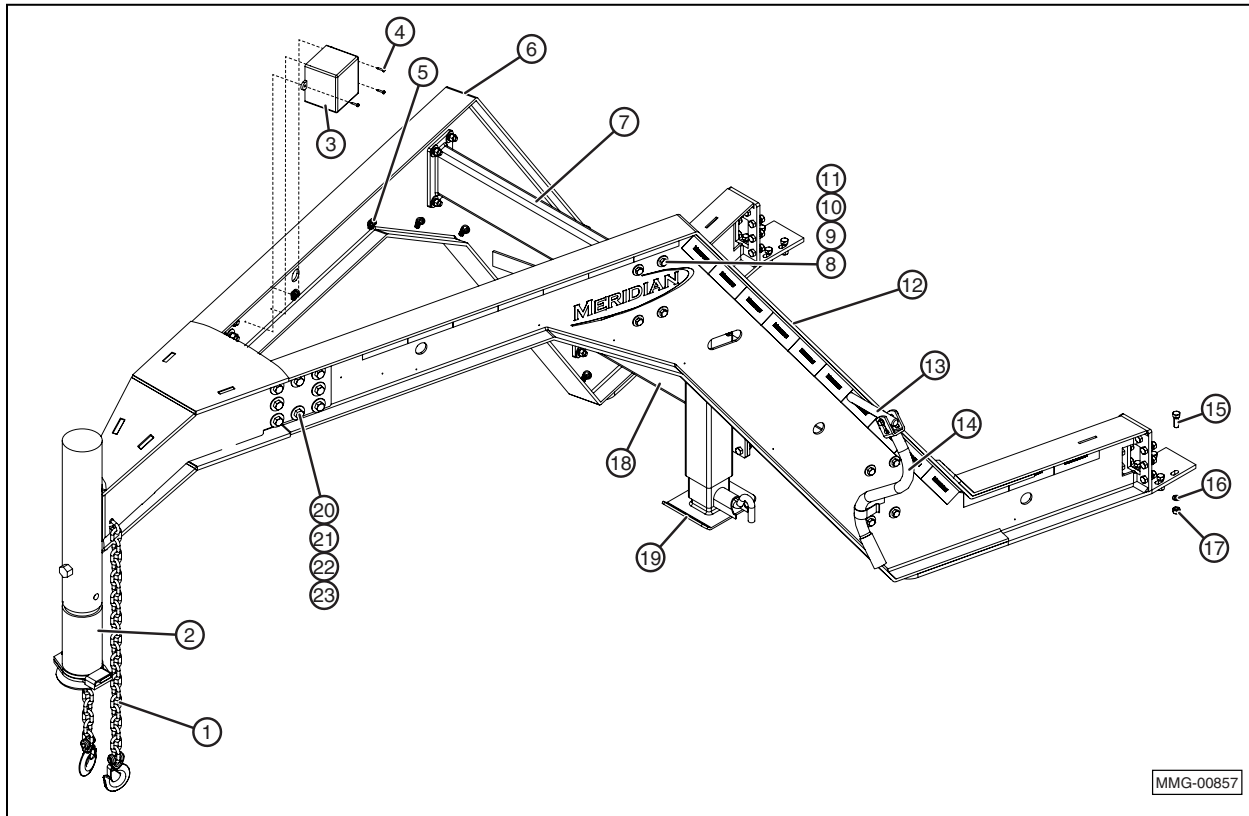

1	2	19171	Chain, Safety with Hook
2	1	25261	Gooseneck Hitch
3	1	19275	Breakaway System
4	3	19779	Screw, Self Drilling
5	7	18679	Clamp
6	1	32040	Weldment, Beam, Gooseneck, (R)
7	1	32042	Weldment, Beam, Upper
8	16	—	Bolt, Hex, 1/2-13 x 1-3/4", Grade 8
9	32	18487	Washer, Flat, 1/2"
10	16	18486	Washer, Lock, 1/2"
11	24	19369	Nut, Hex 1/2-13, Grade 8
12	1	32045	Weldment, Beam, Gooseneck, (L)
13	1	25325	Handle Extension Gooseneck Jack
14	1	18197	Handle, Gooseneck Jack
15	24	19116	Bolt, Hex, 1/2-13 x 1-1/2", Grade 8
16	24	19373	Washer, Lock, 1/2"
17	24	19115	Nut, Hex 1/2-13, Grade 8
18	1	32043	Weldment, Beam, Lower
19	1	25322	Drop Leg Jack Gooseneck
20	16	19375	Bolt, Hex, 5/8-11 x 2", Grade 8
21	32	19384	Washer, Flat, 5/8"
22	16	18460	Washer, Lock, 5/8"
23	16	18351	Nut, Hex 5/8-11, Grade 8
24	12	18096	Tape, Reflective, Meridian

14.8 TITAN SR2 TRAILER HITCH ASSEMBLY

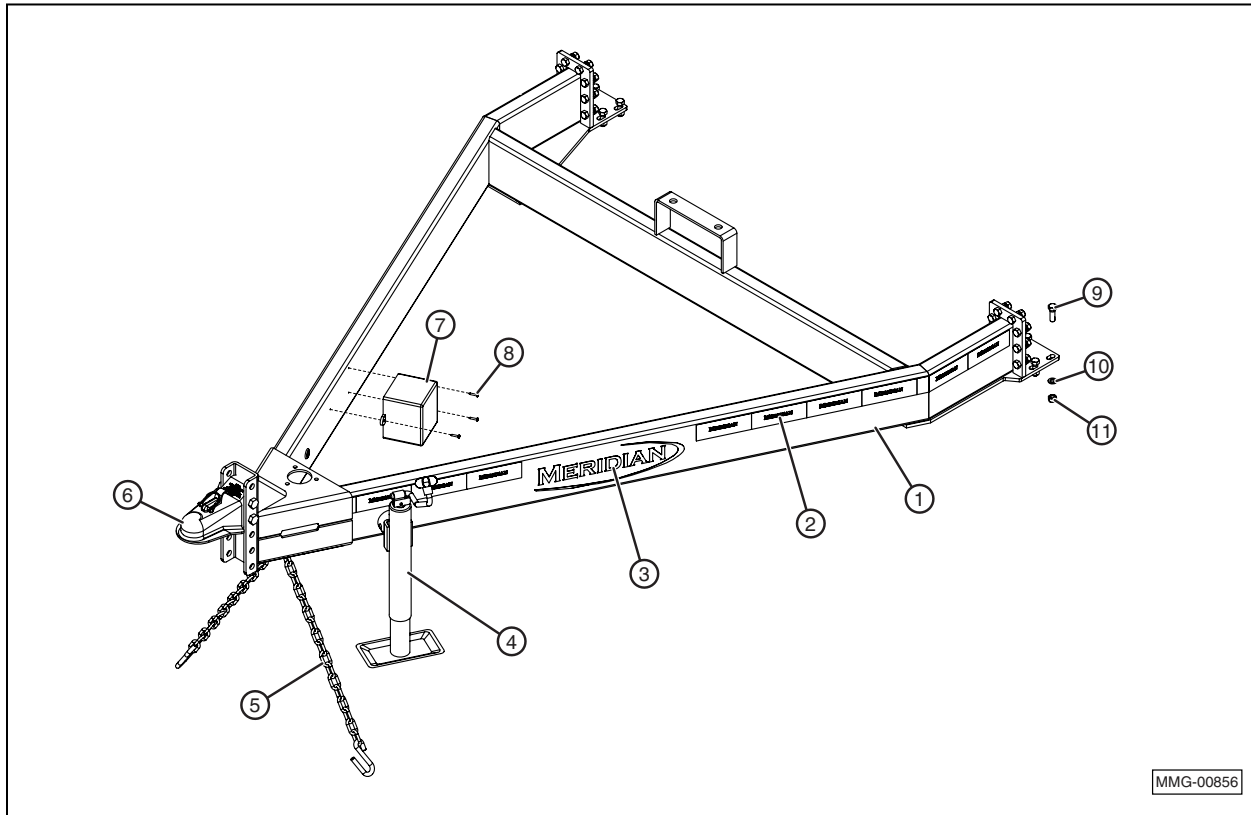

1	1	25851	Weldment, Tongue
2	4	18096	Tape, Reflective
3	2	19911	Decal, Meridian
4	1	18164	Jack, Top Wind A-Frame
5	2	19225	Chains, Safety with Hook
6	1	19298	Hitch, Bumper, 2-5/16" Ball
7	1	19275	Breakaway System, Battery BA10-150
8	18	18091	Washers, Helical Spring Lock
9	24	19116	Bolt, Hex, 1/2-13 x 1-1/2", Grade 8
10	24	19373	Washer, Lock, 1/2"
11	24	19115	Nut, Hex 1/2-13, Grade 8

14.9 TITAN SR2 TRAILER ASSEMBLY

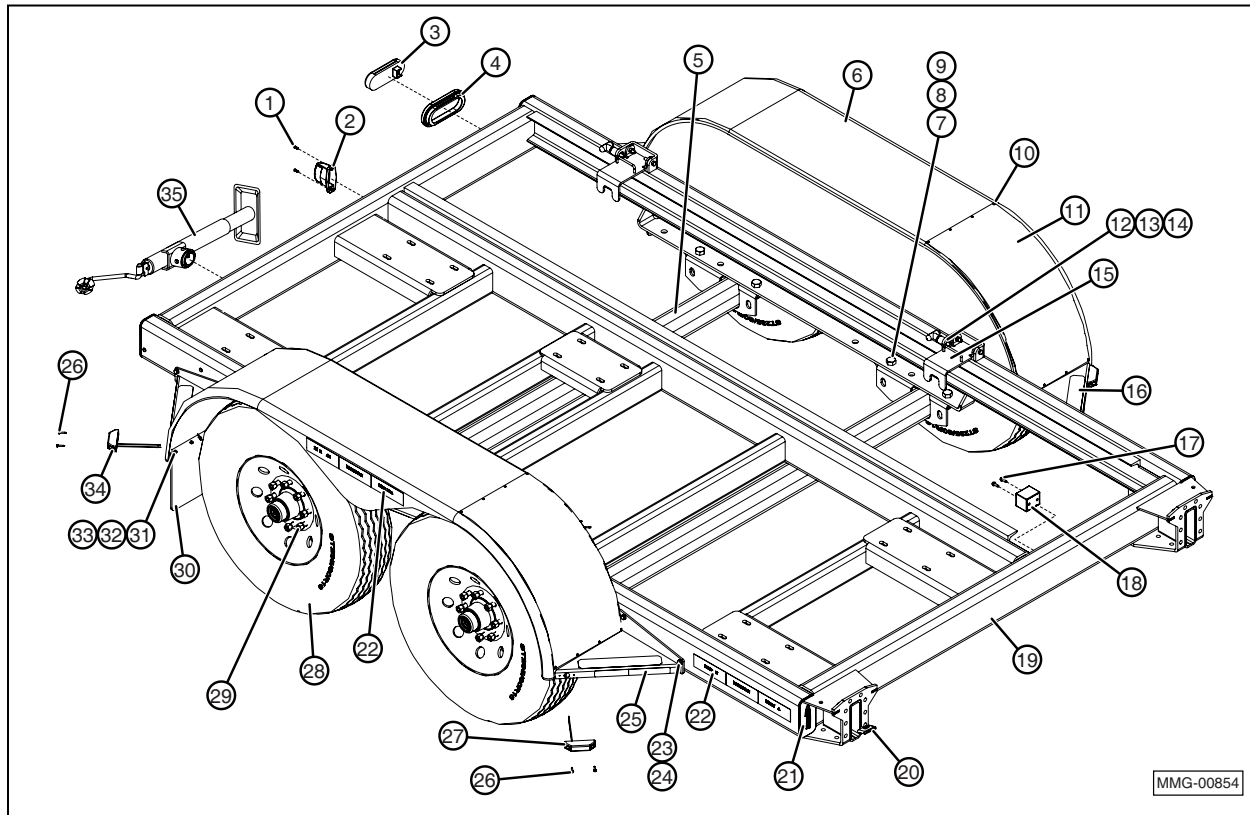

1	2	17673	Screw, Countersunk, Self-Tapping
2	1	17674	Light, License Plate
3	2	17670	Taillight, Red
4	2	17671	Seal, Taillight
5	*	18193	Axle, 7000 lbs.
6	2	17284 11076 —	Fender, (Single Axle) Fender, (Tandem Axle) Fender, (Triple Axle)
7	*	19936	Washer, Lock, 3/4"
8	8	19652	Nut, Hex, 3/4-10
9	*	19388	Bolt, Hex, 3/4-10 x 2"
10	16	17041	Screw, Self Tapping
11	2	20729 22990	Guard, Fender, (Single Axle) Guard, Fender
12	*	19327	Bolt, Hex, 3/8-16 x 1-1/2"
13	*	19347	Nut, Locking, 3/8-16
14	*	17156	Pin, Locking
15	*	32386	Lock, Trolley
16	4	18118	Tape, Anti-Slip
17	2	19597	Screw, Self Drill, 1/4-14 x 3/4"
18	1	17262	Bumper, Rubber

19	1	32393 32387 —	Weldment, Frame, (Single Axle) Weldment, Frame, (Tandem Axle) Weldment, Frame, (Triple Axle)
20	1	32392 17155	Harness, Wire, Single Axle Harness, Wire, Tandem Axle
21	4	17251	Plug, Tube
22	4	22965	Tape, Reflective, Meridian
23	8	11551	Bolt, Hex, 3/8-16 x 1-3/4"
24	4	18153	Washer, Lock
25	4	18153	Tape, Reflective, Fender
26	8	19779	Screw, Self Drilling, #8-18 x 3/4"
27	2	18151	Light, Amber Clearance
28	*	18131	Tire, ST235/80R16
29	*	18991	Nut, Lug, 9/16-18
30	2	19274	Mud Flap
31	8	19112	Nut, Hex, Lock, #8
32	8	19141	Screw, Round Head Pan, #8-32 x 5/8"
33	8	19629	Washer, Flat, #8
34	2	17669	Light, Red Clearance
35	1	18164	Jack, Top Wind, Rear (Single Axle Only)

* Quantity as required per model.

NOTES

MERIDIAN MANUFACTURING INC.

With over 65 years of experience,
Meridian is your storage and handling expert.



AGRICULTURAL



INDUSTRIAL



PETROLEUM



Scan to learn
more about us or
visit our website

Cambridge Office
605 Sheldon Drive
Cambridge, ON N17 2K1
PH: 519-620-6004
TF: 855-346-3712
FX: 519-620-6041

Regina Office
PO Box 1996
Regina, SK S4P 3E1
PH: 306-545-4044
TF: 800-667-5904
FX: 306-545-4216

Camrose Office
4232 - 38 St.
Camrose, AB T4V 4B2
PH: 780-672-4516
TF: 800-830-2467
FX: 780-672-4759

Storm Lake Office
2902 Expansion Blvd.
Storm Lake, IA 50588
PH: 712-732-1780
TF: 800-437-2334
FX: 712-732-1028

Lethbridge Office
3125 - 24 Ave. N.
Lethbridge, AB T1H 5G2
PH: 403-320-7070
TF: 800-661-1436
FX: 403-320-7579

Winkler Office
Box 760, 275 Hespeler Ave.
Winkler, MB R6W 4A8
PH: 204-325-7883
TF: 800-665-7259
FX: 204-325-5556

MERIDIAN[®]
www.meridianmfg.com