

MERIDIAN[®]

OWNER'S MANUAL



meridianmfg.com/hopper-combos



CORRUGATED HOPPER COMBO

PRODUCT REGISTRATION FORM



Attention Dealers:

You can register products online through the Dealer Login: <http://dealers.meridianmfg.com/login/>

It is mandatory to register your product in order to qualify for future warranties that may arise. Knowingly falsifying information on this form will result in the voiding of the product warranty.

You may scan/photograph this completed form (must be legible), email it to: register@meridianmfg.com
A copy of this form may also be mailed to Meridian Manufacturing Inc.

Buyer's Name _____	Dealer's Name _____
Address _____	Address _____
City, Prov/State _____	City, Prov/State _____
Postal/Zip Code _____	Postal/Zip Code _____
Phone Number _____	Phone Number _____

Note: Registering a product in multiple entry format is only allowed when the product has the same model number and the same dealer, however each serial number must be legibly listed for each unit. Delivery dates for a multiple entry must be within a one month time frame.

Product Information: _____

Model Number _____	Serial Number _____
Invoice Date _____	

Important: Please send this form to the Meridian Manufacturing Inc. location which built this product being registered. If you require further assistance call you're dealer or the Meridian® outlet nearest to your location.

We want to thank you for purchasing a Meridian® manufactured product. Whether this is your first Meridian® purchase or you have been a customer for years, you are now part of the Meridian® community of customers and we appreciate your business.

It is important that you now complete the product registration information and this form indicating you have received delivery. This registration and information is necessary to ensure you have access to warranty and product updates in the event it be required in the future.

Registration can be completed by using this form or visiting your dealer who will complete the form online. You will be given access to the Meridian® Community and become eligible for updates, special offers and prizes.

Again, thank you for choosing Meridian.

I have thoroughly instructed the buyer on the above described equipment. The review included the content of this manual, equipment care, adjustments, safe operation and warranty policy.

Date _____ Dealer's Signature _____

The above equipment and this manual have been received by me. I have been thoroughly instructed as to care, adjustments, safe operation and applicable warranty policy.

Date _____ Buyer's Signature _____

This page intentionally left blank

TABLE OF CONTENTS

DESCRIPTION	PAGE
<u>Section 1: INTRODUCTION</u>	1-1
1.1 Serial Number	1-1
<u>Section 2: SAFETY</u>	2-1
2.1 Safety Orientation	2-2
2.2 General Safety	2-2
2.3 Equipment Safety Guidelines	2-3
2.4 Safety Decals	2-3
2.4.1 Applying Decals	2-3
2.5 Decal Location	2-4
2.6 Work Preparation	2-4
2.7 Operating Safety	2-5
2.8 Maintenance Safety	2-6
2.9 Lock-Out Tag-Out Safety	2-6
<u>Section 3: SITE AND INSTALLATION</u>	3-1
3.1 Bin Location	3-1
3.2 Bin Foundation	3-2
3.3 Concrete Slab Construction	3-3
3.4 Installation	3-5
<u>Section 4: OPERATION</u>	4-1
4.1 Components and Controls	4-2
4.2 Optional Equipment	4-4
4.3 Meridian Airmax™	4-6
4.4 Loading	4-8
4.5 Unloading	4-9
<u>Section 5: SERVICE AND MAINTENANCE</u>	5-1
5.1 Concrete Slab Inspection	5-2
5.2 Bin Inspection	5-2
<u>Section 6: REFERENCE</u>	6-1
6.1 Bin Specifications	6-1
Warranty Statement	

This page intentionally left blank

Section 1: INTRODUCTION

Thank you for choosing a Meridian® Corrugated Hopper Combo.

This product has been designed and manufactured to meet the exacting standards for such equipment in the agricultural industry.

Keep this manual for future reference. Call your dealer, distributor or Meridian if you need assistance, information, additional/replacement copies, or a digital copy of this document.

Information provided herein is of a descriptive nature. Meridian Manufacturing Inc. reserve the right to modify the equipment design and specifications without any preliminary notice.

Performance quality may depend on the product being handled, weather conditions and other factors.

Bin specifications, features and available options may vary depending on the region.

SERIAL NUMBER

The serial number is located above the safety decals, on the hopper leg where the crank is attached.

Have the serial number available when communicating with the dealer or factory and requesting service or asking for information.

Use the space provided for easy reference.

Bin Model No: _____

Bin Serial No: _____

Auxiliary Equip: _____



Fig 1 - Serial number location on hopper leg



Meridian Manufacturing Inc. continuously enhances its product offering through product improvements and new product innovations. Marketplace feedback, technological innovation, new materials and manufacturing methods, and a philosophy of continuous improvement constantly challenge the company to develop new and better ways of addressing market needs. Meridian is committed to innovation and reinvestment and as a result, the company maintains a portfolio of patents and intellectual property. For more information on our patents please see our website:

www.meridianmfg.com/patents

Section 2: SAFETY

3 Big Reasons why safety is important to you:

- Accidents Disable and Kill
- Accidents Cost
- Accidents Can Be Avoided

The Safety Alert Symbol means:



The Safety Alert Symbol identifies important safety messages on the bin and in this manual.

The following signal words are used in this manual to express the degree of hazard for areas of personal safety.

When you see the symbol and/or the signal words described below, obey the accompanying message to avoid possible injury or death.



Indicates a hazardous situation that, if not avoided, will result in death or serious injury. This signal word is limited to the most extreme situations. Typically for machine components which, for functional purposes, cannot be guarded.



Indicates a hazardous situation, if not avoided, could result in death or serious injury. This word identifies hazards that are exposed when guards are removed. It may be used to alert against unsafe practices.



Indicates a hazardous situation, if not avoided, could result in minor or moderate injury. It may be used to alert against unsafe practices.



Indicates practices or situations which may result in the malfunction of, or damage to equipment.



Safety instructions (or equivalent) signs indicate specific safety-related instructions or procedures.

2.1 SAFETY ORIENTATION

YOU are responsible for the SAFE usage and maintenance of your Meridian® Corrugated Hopper Combo. Be sure that everyone who will maintain or work around it, is familiar with the safety, maintenance procedures.

This manual will take you step-by-step through your working day. It will alert you to all the safe practices that should be adhered to while using the bin.

Remember, you are the key to safety. Good safety practices not only protect you but also the people around you. Make these practices a regular part of your safety program. Be certain that everyone who will work with this equipment follows these procedures.

Most accidents can be prevented. Do not risk injury or death by ignoring good safety practices.

- Bin owners must give instructions to employees before allowing them to use the bin.
 - Procedures must be reviewed annually thereafter, as per OSHA (Occupational Safety and Health Administration) regulation 1928.57.
 - The operator must be responsible, properly trained and physically able. You should be familiar with farm machinery in general.
- Develop a comprehensive safety program for your work area.
- Think SAFETY! Work SAFELY!

2.2 GENERAL SAFETY

- You are responsible for the safe use and maintenance of this bin. Good safety practices not only protect you, but also those around you. All accidents can be avoided.



- Use this corrugated bin for its intended purpose.
- This bin is not intended for use by children.

2.3 EQUIPMENT SAFETY GUIDELINES

- Safety of the workers and bystanders is one of the main concerns when designing and developing this bin. However, every year many accidents occur which could have been avoided by a few seconds of thought, and a more careful approach to handling equipment.
- DO NOT allow personnel to use this tank until they have read this manual. They should have a thorough understanding of the safety precautions.
 - Review the safety instructions with all users annually.
- Do not modify the equipment in any way. Unauthorized modification result in serious injury or death and may impair the function and life of the equipment.

2.4 SAFETY DECALS

- Keep safety decals clean and legible at all times.
- Replace safety decals that are missing or have become illegible.
- All safety decals have a part number in the lower right hand corner. Use this part number when ordering replacements.
- Safety decals are available from your authorized distributor, dealer's parts department or from Meridian Manufacturing Inc.

2.4.1 Applying Decals:

1. Be sure the application area is clean and dry. Ensure the surrounding temperature is above 10°C (50°F).
 - a. Remove all dirt, grease, wax from surface.
 - b. Clean the area with a non-ammonia based cleaner.
 - c. Wipe the clean surface with isopropyl alcohol on paper towel, and allow to dry.
2. Determine the exact position before you remove the backing paper.
3. Peel a small portion of the split backing paper.
4. Align the decal over the specified area. Use a squeegee to carefully press the small portion, with the exposed adhesive backing, into place.
5. Slowly peel back the remaining paper and carefully smooth the rest of the decal into place.
6. Small air pockets can be pierced with a pin and smoothed out using the squeegee, or a piece of sign backing paper.

2.5 DECAL LOCATION

The safety decal(s) are located on the hopper leg where the crank is attached.

Fig 2 - Safety decal



19977SK-70

2.6 WORK PREPARATION

- Work only in daylight or good artificial light.
- Clear working area of stones, branches or hidden obstacles that might be hooked or snagged, causing injury or damage.
- Be sure all machine is in a stable position, is adjusted and in good operating condition.
- Ensure that all safety guards and safety decals are properly installed and in good condition.
- Install and secure all guards on auxiliary loading/unloading equipment be using it.
 - Safety decals must be in good condition.
- Before starting, inspect all equipment for any loose bolts, worn parts, cracks, leaks or frayed belts. Make the necessary repairs.
- **PROLONGED EXPOSURE TO LOUD NOISE MAY CAUSE PERMANENT HEARING LOSS!**

Agricultural equipment can often be noisy enough to cause permanent, partial hearing loss. We recommend that you wear hearing protection on a full-time basis if the noise in the operator's position exceeds 80 db.





Noise over 85 db on a long-term basis can cause severe hearing loss.

Noise over 90 db adjacent to the operator over a long-term basis may cause permanent, total hearing loss.

Note:

Hearing loss from loud noise (tractors, chain saws, radios, etc.) is cumulative over a lifetime without hope of natural recovery.

2.7 MAINTENANCE SAFETY

- Create a Lock-Out Tag-Out program for the auxiliary equipment used to load and unload the bin.
- These bins can store a variety of products and each site is different. It is important to develop an applicable maintenance program to suit your specific work place.
- Do not crawl under the opened unloading chute to inspect for a suspected blockage. Product could suddenly break loose and cause facial and/or eye injury.
- If you enter the bin:
 - Lock out the power sources for all equipment.
 - Have a responsible person close at hand in case of an emergency.
- Use personal protective equipment (PPE) such as eye, hand, breathing and hearing protectors, when performing any service or maintenance work. 
- Enter the empty bin with extreme caution:
 - Wear protective clothing, and a properly filtered respirator mask to protect against chemical vapour or residual dust.
 - Connect a safety line to yourself and have a responsible, trained person outside in case of an emergency.
- A fire extinguisher and first aid kit should be kept readily accessible while performing maintenance on this equipment. 
- Periodically tighten all bolts, nuts and screws and check that all cotter pins are properly installed to ensure the bin and auxiliary equipment are secure.

2.8 OPERATING SAFETY

- Make sure that anyone who will be using the bin or working on or around it reads and understands all the operating, maintenance and safety information in the owner's manual.
- Keep all bystanders, especially children, away from the bin when loading or unloading is being done, or when authorized personnel are carrying out maintenance work.
- Do not crawl under the opened unloading chute to inspect for a suspected blockage. Caked or impacted product could suddenly break loose and cause facial and/or eye injury.
- Do not attempt to enter the bin through the top loading hatch. This opening is designed for loading the bin only and not for human entry.
- Use the optional roof manhole only for entry into the bin and only when the bin is empty for cleaning purposes.
- If you enter the bin, ensure that there is no possibility that the loading or unloading auger could be started up.
 - Lock out the power sources for all equipment.
 - Have a responsible person close at hand in case of an emergency.
- Enter the empty bin with extreme caution. Wear protective clothing, goggles and a properly filtered respirator mask to guard against chemical vapour or residual dust.
 - Connect a safety line to yourself and have a responsible, trained person outside, holding the line, in case of an emergency.
- Do not enter the bin to break loose impacted, caked or bridged material. You could fall through the bridged material if you are trying to clear it from the top. Or have it cave in on you from the bottom. Either situation could result in you being buried in the falling material and suffocating.



- If material is bridged or caked causing a blockage. Use a long pole, a length of board to break the material loose.
- Be very careful when climbing up or down the exterior ladder. Remove excess mud or other material from your footwear that could cause slipping.
 
- Make sure the safety section of the access ladder is raised and latched in place to prevent children and other unauthorized persons from climbing up on the bin.
- The optional roof manhole should not be used to load or unload material. This will cause the material to be off-centre, either piling up or emptying unevenly to one side of the bin. This uneven stressing of the bin could cause structural damage.

2.9 LOCK-OUT TAG-OUT SAFETY

- Establish a formal Lock-Out Tag-Out program for your work site.
- Train all operators and service personnel before allowing them to work around the area.
- Provide tags on all auxiliary equipment and a sign-up sheet to record tag-out details.

This page intentionally left blank

Section 3: SITE AND INSTALLATION

WARNING

- Read and understand the owner's manual.
- Clear the area of bystanders, especially children, before starting.
- Prepare the base carefully to be sure the bin is supported evenly to prevent tipping.
- Stay away from power lines when lifting or moving the bin. Electrocutation can occur without direct contact.
- Move the bin on a calm day or light breeze. The bin is a large, hard-to-handle object that can easily be caught and moved by the wind.
- Use extra care when moving bin. Never move a bin with product in it.
- Use only an approved hoist, crane or other lifting system when positioning bin.
- Secure, anchor the base when positioned.

3.1 BIN LOCATION

Unless otherwise specifically provided in writing, Meridian® does not take responsibility for any defects or damages to any property, or injury to any persons, arising from or related to any site or assembly considerations, including but not limited to:

- Bin location and siting.
 - Soil conditions and corresponding foundation requirements.
 - Field modifications or equipment additions that affect the bin structure.
 - Interconnections with neighbouring structures.
 - Compliance with all applicable safety standards, including but not limited to, fall restraint systems (ladders or other systems). Local safety authorities should be contacted as standards vary between jurisdictions.
- It is important that you, the customer, plan the work site to minimize or eliminate the need to move the bin(s) once positioned.
- We recommend that you consult a civil engineer regarding the chosen site, the soil load bearing capacity, proper method of construction and type of concrete pad.
 - Clear area of bystanders, especially children.
 - Use only hoists or cranes with sufficient lift capacity and reach for the bin being positioned.
 - Do not move or transport the bin when it is windy. Wait for a calmer day.
 - Ensure the bin is positioned on a base that has been properly prepared to support the weight and loads of the bin when filled.
 - Electrocutation can occur without direct contact. Do not place bin within 40 ft from power lines.

3.2 BIN FOUNDATION

The following foundation specifications shall be interpreted as recommendations only. We recommend that you consult a civil engineer regarding the chosen site. Because of the many variable soil conditions, Meridian Manufacturing Inc. assumes no liability for results arising from the use of the recommendations. However, these minimum standards must be respected to assure bin warranty applicability.

• Gravel Base:

Meridian® hopper combo bins installed with steel skid bases require proper site preparation to prevent damage or possible overturning.

- The site should be in a well-drained location with all silt, organic, and loose soil removed. Topsoil should be excavated to a depth equivalent to the depth of the gravel base specified below.
- Provide a compacted gravel base of sufficient depth and bearing capacity as follows:
 - 21 ft dia. hopper (23 ft max. wall height)
 - 18 in. depth at 4500 lb/ft²
 - 24 ft dia. hopper (23 ft max. wall height)
 - 24 in. depth at 5000 lb/ft²
 - 27 ft dia. hopper (23 ft max. wall height)
 - 30 in. depth at 6000 lb/ft²
- The gravel base should extend beyond the inner and outer perimeter of the foundation a distance equal to the depth of the gravel base.
- The compacted gravel base must be level within $\pm 3/8$ ". This condition must be maintained even after loading in order to prevent damaging eccentric loading.
- The foundation must contact the gravel base at all points around its perimeter. Gaps between the foundation and the gravel are not acceptable.
- The assembled foundation, hopper, and bin should be anchored to prevent the overturning from wind when empty.

• Concrete Slab:

We recommend that you consult a civil engineer regarding the site you choose, the soil conditions, and soil load bearing capacity. A professional engineer can advise on the proper method of construction and type of concrete slab for your needs.

The best type of base, and the one we recommended, is a concrete slab that is located on well drained, level ground that is capable of supporting the concrete slab and a full bin under all environmental conditions.

The design of a concrete slab is based on varied load bearing specifications for the different sized corrugated bins. Meridian® is not responsible for damage caused by an inadequate concrete slab. It is the responsibility of the owner to ensure that good construction practices are followed to obtain the required load carrying capacity for the slab. A concrete slab built to the proper performance specifications will ensure a long, trouble-free life for the storage system.

Meridian® can provide your engineer with the required information, such as bin design and leg reactions (wind and weight load).

The bin must be bolted to the slab so that all the legs or bolt plates sit evenly and are firmly in contact with the concrete. If the concrete is uneven, full "leg base plate" shims can be used.

3.3 CONCRETE SLAB CONSTRUCTION

The following information provides specifications and general guidelines for construction of concrete slabs for supporting bins.

It is very important that close attention be given to site preparation and soil conditions in order to provide a good base for the concrete slab.

Items to be aware of include but are not limited to the following:

1. **Soil Conditions:**

Sod and other organic material must be removed before laying down the gravel fill. Positive drainage must be provided to drain excessive moisture away from the concrete slab.

The concrete slab is designed for load stresses on soils with minimum allowable soil bearing capacity of 1500 psf.

The engineer is not responsible for concrete slab performance on soils with lower than specified bearing capacity or soils that are unsuitable for supporting a concrete pad.

Soil conditions should be assessed on the basis of soil tests, or of the performance history of similar structures in your local area.

2. **Slab Structures:**

The following specifications must be followed to construct a concrete slab to meet the load and stress carrying requirements:

- The concrete must have a minimum 28 day strength of 3000 psi (1361 kg).
- Use sulphate resistant cement where required by soil conditions.
- Do not pour concrete on frozen ground or in an excavation that contains ice, snow, excessive moisture or when the air temperature is below 4°C (40°F).

3. **Foundation Specifications:**

- a. All foundations must be designed on leveled soil with a bearing capacity of 3,000 psf (14,646 kg/m²). When in doubt, consult a local engineer or architect.
- b. All soil or organic material on the site of the foundation must be excavated and replaced by porous frost-proof material to provide proper draining under foundation and reduce frosting problems (gravel, sand, ballast, crushed stone). This underlying basis is then compacted and covered with polyethylene plastic which acts as a moisture barrier.
- c. Once the forms have been prepared, begin the placement of reinforcement rods in the foundation (see foundation drawing details). The reinforcement rods offer their greatest strength when they have been joined together, either by weld or wire. 6 x 6" (15.24 x 15.24 cm) wire mesh or 10M (#3) at 12" O/C each way covering the entire area of the foundation, completes preparation before beginning concrete pouring.
- d. Concrete must have a minimum compressive strength of 3,000 psi (20.7 MPa) after 28 days.
- e. Approximative concrete volume quantities found in the corresponding table.
- f. Foundation surface must be level. Columns must be shimmed in uneven circumstances.
- g. Follow general concrete best practices and guidelines. Wait a minimum of 7 days to install the bins on concrete. It is recommended to wait 28 days until filling the combo hopper bin, to ensure full concrete strength is achieved.

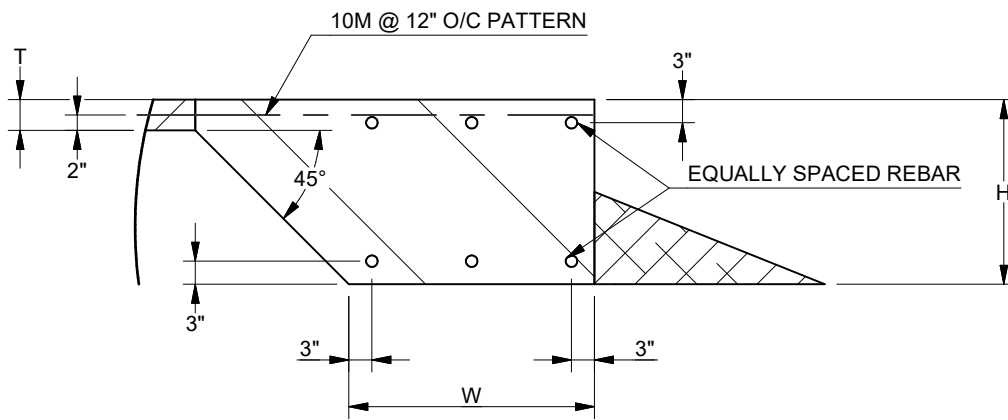
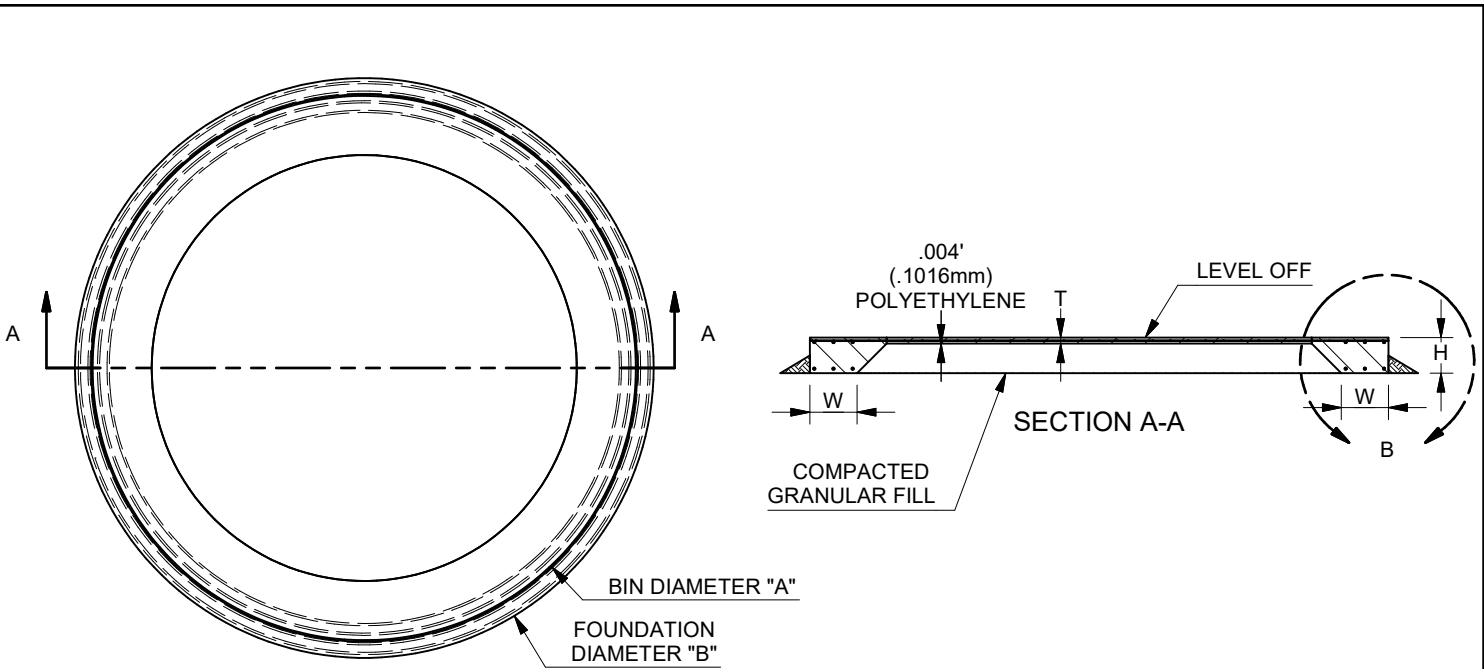

DETAIL B

Table 1 - Hopper Combo Concrete Details

BIN DIAMETER "A"	FOUNDATION DIAMETER "B"	REBAR		CONCRETE		
		METRIC	IMPERIAL	HEIGHT "H"	WIDTH "W"	THICKNESS "T"
15' (4.57m)	17' 6"	3-15M	3-#5	18"	42"	4"
15' 10" (4.82 m)	19' 0"	3-15M	3-#5	18"	42"	4"
18' (5.49 m)	21' 0"	3-15M	3-#5	18"	42"	4"
18' (5.49m)	21' 0"	3-15M	3-#5	18"	42"	4"
21' (6.40m)	24' 0"	3-15M	3-#5	18"	42"	4"
24' (7.32m)	27' 0"	3-15M	3-#5	18"	42"	4"
27' (8.23m)	30' 0"	3-15M	3-#5	18"	42"	4"

Notes: Concrete specs for DC bins installed on other manufactures hopper cones should be sourced from that manufacture
 - Maximum sidewall height = 23'-0" (6 Rings)
 - Maximum product bulk density = 50 PCF

3.4 INSTALLATION

Care must be used when moving, lifting and installing the bin. Installation instructions include but are not limited to:

- Clear the area of bystanders, especially small children.
- Have at least one other trained and responsible person to assist and who, in case of an emergency or accident, can provide assistance or seek assistance.
- Stay away from power lines when lifting or moving the bin. Do not place a bin within 40 ft from power lines.

Electrocution can occur without direct contact.

- Never move a bin that has product in it. The legs, base and supporting structure are not designed with sufficient strength to carry the combined mass. Any structural damage occurring during the move, can lead to more problems or damage when the bin is filled at its final position.
- Do not use tow hooks on a temporary skid base to pull the bin with any product inside. Because of the inherent high centre of gravity and the pulling force that would be concentrated at the tow hooks, the bin would tip over, creating a safety hazard.
- If the unit must be pulled, make sure that it is completely empty and that the area that it will be pulled over is firm, level and contains no obstructions. Proceed with extra caution. The bin is top heavy, having a high centre of gravity and can tip easily.
- Use only a crane, hoist or lift with sufficient load carrying and reach capacity. It must have the appropriate stability to raise, move, position and lower the bin.

- It is recommended that installing the bin be done on a calm day or one with light winds. A bin is a large, hard-to-handle object that can easily be caught and moved by the wind.

Note:

It is easier to position the top lid before placing the bin than after.

- Determine where the auger or conveyor will be when loading the bin. The position of this equipment will determine the rotation of the top lid, covering the loading hatch, at the peak of the bin. The lid will need to be opened and out of the way of the loading equipment.
 - Loosen the lid clamping bolts and rotate it to the required position prior to securing the bin into its permanent position.
 - Tighten the clamping bolts to their specified torque and tie the rope to the lid handle.
- Be sure the base cannot move.
 - Stake the skid plate when equipped with a temporary base.
 - Bolt the base to the permanent concrete pad.

If the base can move, it can lift or slide which leads to tipping.



Fig 3 - Unloading bin

This page intentionally left blank

Section 4: OPERATION

WARNING

- Read and understand the owner's manual.
- Keep all bystanders, especially small children, away from bin(s) when loading, unloading or performing maintenance work.
- Do not unload bin from the side. Uneven loading can cause side loads and damage the structure.
- Do not crawl under opened unloading chute to inspect for a suspected blockage.
- Use a long pole or plank to dislodge and break the material loose while outside bin.
- Do not attempt to enter bin through the top loading hatch.
- Only enter bin when it is empty.
- Wear appropriate safety gear including but not limited to protective clothing, goggles and respirator before entering bin. Attach a safety line to an anchor outside.
- Use care when climbing ladder to prevent falling.
- Raise and latch ladder in the up position when not being used to prevent unauthorized use.

This Meridian® Hopper Combo is designed to be used in with grain storage operation. There is a wide variety of options and auxiliary equipment which can be used to load and unload product.

It is the responsibility of the owner and users to be familiar with the bin(s) and all the auxiliary loading/unloading equipment before starting. Read the equipment manuals and train all personnel before they start working with the machine. Follow all safety instructions exactly - it is everyone's business. By following the recommended procedures, a safe working environment is provided for the workers and bystanders in the work site.

The design and configuration of this bin includes safety decals. Hazard controls and accident prevention are dependent upon the personnel working with and maintaining it. Their awareness, concern, prudence and proper training are crucial.

Many features incorporated into this bin are the result of suggestions made by customers like you.

By following these instructions, in conjunction with a good maintenance program, your bin will provide many years of trouble free storage.

4.1 COMPONENTS AND CONTROLS

Bin specifications, components and available options may vary depending on the region. The location of components and options may vary and change without notice.

One Piece Cone Hopper:

Cone hoppers are available in one piece. 15 ft diameter bins have a 40° cone, and the 16-21 ft diameter cones have a 35° cone.

Split Hopper Cone:

Split hopper cones are available for 24 ft and 27 ft diameter bins. They have a 35° cone.

These hopper cones have bolt-on legs.

Unloading Chute with Slide Gate:

The unloading chute at the base of the cone comes with a rack and pinion slide gate assembly. A crank is used to work the gate.



Fig 4 - Open piece hopper with skid base



Fig 5 - Split hopper cone



Fig 6 - Unloading chute with slide gate and crank

⚠ WARNING
FALLING HAZARD
Use extreme caution when climbing.

Sidewall and Roof Ladder:

Each bin is designed and built with a roof and sidewall ladder. One section of the sidewall ladder is connected to each corrugated bin ring.



Fig 7 - SC Roof ladder



Fig 8 - DC Roof ladder

27" Bin Lid:

This patent pending lid, covering the 27 inch loading hatch, is spring-loaded and has a remote lid opener.

A cable is attached to the lid, extends down to the ground, and is connected to a leg. Pull it to open the lid, release it to close.



Fig 9 - Loading hatch covered by the lid

Sealed Roof Eave:

The DC bin roof wraps over the top bin sheet to created a sealed roof eave.



Fig 10 - Sealed roof eave

4.2 OPTIONAL EQUIPMENT

The location of options may vary and change without notice. Not all options may be available in all regions.

Ladder Cage:

This cage surrounds the ladder to reduce the chance of falling.



Fig 11 - Ladder Cage

Spiral Staircase:

This staircase is available for 18' to 27' hopper combos.



Double or Triple Skid:

A double or triple skid base is available to bolt the hopper legs.



Fig 12 - Triple skid

Bottom Manway:

This access hole is located on the cone and provides access to the interior of the bin. Do not use it to dislodge bridged material inside the bin.



Fig 13 - Bottom manway

Auger Boot:

This assembly allows an auger to fit into the bottom cone of the Bin and provides for easy and convenient unloading.



Fig 14 - Auger boot

Utility Auger:

A utility auger is available for convenient unloading. It is available in 4, 6, 8 and 10 inch diameters. The tube is a standard 16 foot length, and extensions are available.

LevALERT® Bin Level Indicator:

LevALERTs are available for installation on the sidewall of the bin. The indicator turns a bright yellow colour when the product inside the bin reaches that point or is above it.

- LevALERT can be installed at any time, and are available with an optional proximity switch to control lights, alarms, etc.



Fig 15 - LevAlert® bin level indicator

Additional Options:

- Roof Vents
- Leg Extensions
- Grain or Feed Boot
- Transitions
- Fan Mounting Brackets

Note:

A variety of control systems and switches are available to be used with your storage system for loading and unloading.

Always have a licensed electrician provide the power and controls for your system. All wiring should comply with the ANSI/NFPA 70 electrical requirements.



Fig 16 - Roof vents and stiffeners

4.3 MERIDIAN AIRMAX™ AERATION SYSTEMS

One of these patent pending Airmax™ Aeration systems may have come with your bin to condition the product stored inside.

NOTICE

CORROSIVE MATERIAL HAZARD
Do not store fertilizer in a bin containing an aeration system.



Fig 17 - Horizontal AirMax™ Aeration tube

4.3.1 Airmax™ Horizontal Aeration System:

The horizontal aeration tube is inserted through the fan mount. Then the fan can be installed.

- Bolt the in-line fan to the mount in a way that the electrical lines can be routed conveniently.

The aeration tube is removable, to facilitate cleaning of the screen.

- Remove the fan, then unfasten the bolts and carefully pull the tube out of the bin.
- Once the tube is removed, replace the cover plate to prevent moisture and pests from entering the bin.



Fig 18 - AirMax™ Inline fan

Fig 19 - Vertical Aeration
-One-Piece

Fig 20 - Vertical Aeration
-Sectional



Horizontal Aeration Disclaimer:

Remove the horizontal aeration tube if fertilizer will be stored in the bin. If left inside, it could limit or void the warranty if the cause of a claim is deemed to be from the storage of fertilizer.

4.3.2 Airmax™ Vertical Aeration System:

The internally mounted “rocket” has a hollow duct design formed by a self-cleaning perforated metal screen.

Bolt the centrifugal fan to the mount on the hopper bottom.



Fig 21 - AirMax™ Centrifugal fan

Note:

- Vertical Aeration is available in 30” or 45” diameters.
- Horizontal Aeration is available in 18” or 24” round aeration tubes.
- Order them to be installed in the factory or as a bolt-in sectional kit to be installed into existing hopper bins.

Table 2 - Meridian Airmax™ Specifications

Models	Max Bin Size (Bushels) ¹	Dimensions	Dia. I.D.	Weight (LB)	Screen Surface (Inches)	Inlet Size and Type	Height into Grain Cavity 35° Cone ³	Height into Grain Cavity 40° Cone ³	Height into Grain Cavity 55° Cone ³
Vertical Aeration – One Piece									
V3004	3500	30” x 4’	20”	385	6299	9” x 14” Rect	n/a	86”	n/a
V3006	5000	30” x 6’	20”	440	9656	9” x 14” Rect	n/a	110”	n/a
V3008	6000	30” x 8’	20”	525	13132	9” x 14” Rect	n/a	134”	n/a
V4504	7000	45” x 4’	30”	580	9301	14” x 17” Rect	n/a	95”	n/a
Vertical Aeration – Sectional (Designed for Retrofitting Existing Hopper Bins and High-Flow Applications) ⁴									
VS3004	5000	30” x 4’	20”	420	5245	9” x 14” Rect	80”	86”	99”
VS3006	8000	30” x 6’	20”	500	7990	9” x 14” Rect	104”	110”	123”
VS4504	15000	45” x 4’	30”	600	7925	14” x 17” Rect	88”	95”	116”
VS4506	20000	45” x 6’	30”	745	12100	14” x 17” Rect	112”	119”	140”
Horizontal Aeration (Removable for Fertilizer Storage and Available for Retrofitting Existing Bins)									
H1808	5000	18” x 8’	n/a	155	3478	18” Rnd	38”	44”	n/a
H2408	6500	24” x 8’	n/a	235	4660	24” Rnd	44”	50”	n/a
H2410	6500	24” x 10’	n/a	285	6284	24” Rnd	51”	59”	n/a
H2410-HD	8,500	24” x 10’	24”	360	6284	24” Rnd	51”	59”	n/a
H2412-HD	11,000	24” x 12’	24”	425	7908	24” Rnd	58”	68”	n/a

1. Recommended bushel capacities for Meridian AirMax® system.
2. Recommended bin model(s) for maximum grain drying and aeration results.
3. Distance from gate to top of aeration mechanism.
4. Meridian AirMax™ Sectional system is an exclusive and unique aeration product allowing installation of vertical aeration in existing hopper bins. This unit is built heavier than the one-piece Meridian AirMax®, withstanding weights up to 20,000 bushels.

4.4 LOADING

The bin(s) are designed to be easy to load with product. This list of general guidelines will help you in the loading process:

- A spring-loaded lid covers the loading hatch and can be opened from the ground by pulling on the cable provided. The lid will automatically close when the cable is released.
- The lid can be rotated to open in any direction. Before erecting the bin, decide on the opening direction and make the adjustment. This will be more convenient than waiting until the bin is set in place.

NOTICE

STRUCTURAL DAMAGE HAZARD

Do not load bin off-centred.

Side piling will cause structural damage.



Fig 22 - Loading the bin

- A bin should always be centre loaded and unloaded to prevent uneven stresses caused by product piling up on one side and emptying from the other. Over-stressing in this manner will cause eventual structural damage. The loading hatch at the peak of the bin will facilitate centre-loading.
- The unloading chute at the base of the bin is designed to centre unload product.
- Do not, under any circumstances, attempt to use the optional roof manhole as either a loading port. The material will pile up unevenly, creating a situation that could cause damage to the bin.

4.5 UNLOADING

The standard hopper combo is designed with two feet of clearance at the bottom of the cone to provide room for unloading equipment. Use auxiliary unloading equipment as appropriate for your storage system.

A general list of guidelines to be followed include but are not limited to:

NOTICE

IMPLOSION HAZARD

Check that all air vents are clear and open before emptying tank.

- Remember to regularly inspect the air vents to be sure they are not clogged.
- To unload product from the bin, use the crank to open the slide gate below the chute. The emptying rate is determined by how far the slide gate is opened.

Optional permanent auger mounts and boots to enclose the unloading chute are available to complement the functioning of your storage bin.

- If product cakes to the side, an uneven stress is generated on the bin structure and could cause structural damage. In most cases, banging the side of the bin with a rubber mallet will loosen the product. Another option is to use a long pole or piece of wood through the inspection manhole to break the caked material free.
- Do not crawl under an opened unloading chute to inspect for a suspected blockage. Caked or impacted product could suddenly break loose and cause facial, body and/or eye injury.

- Do not attempt to enter the bin through the loading hatch at the peak. This opening is designed for loading the bin only and not for human entry.
- Enter the roof manhole only when the bin is empty, for cleaning purposes.
- Use the bottom manway to enter the bin only when it is empty, for cleaning purposes.
- If you enter the bin, make sure that there is no possibility that the loading/unloading auger could be started up.

IMPORTANT:

Lock-Out Tag-Out the power sources to all auxiliary equipment and have a responsible, trained person close at hand to keep unauthorized individuals away from the work area.

- Enter the empty bin with extreme caution. Wear protective clothing, goggles for eye protection and a properly filtered respirator mask for lung protection.

It is also good safety practice to connect a safety line to yourself and a secure attachment point outside the bin before entering the enclosed area. Have a responsible, trained person outside to assist in case of an emergency.

This page intentionally left blank

Section 5: SERVICE AND MAINTENANCE

WARNING

- Read and understand the owner's manual.
- Keep all bystanders, especially small children, away from the bin(s) when performing maintenance work.
- Establish a Lock-Out, Tag-Out program for your work site. Always Lock-Out, Tag-Out equipment before entering the bin or performing any maintenance work
- Do not crawl under opened unloading chute to inspect for a suspected blockage.
- Use care when climbing ladder.
- Do not attempt to enter bin through the top loading hatch.
- Only enter bin when it is empty. Attach a safety line to an anchor outside before entering.
- Wear appropriate personal protective gear, for the task you are performing. Wear a respirator when entering the bin.

Each work site is different. You must develop a service and maintenance program specific to your location and circumstances. You are responsible to ensure that your hopper bottom corrugated bin(s) are compatible with the product which you wish to store.

By following a careful service and maintenance program for your bin(s), you will enjoy many years of trouble-free storage.

IMPORTANT:

If you enter the empty bin, make sure that there is no possibility that loading could start up. Lock-Out, Tag-Out all auxiliary equipment. A responsible, trained person must be close at hand for assistance.

WARNING

CONFINED SPACE HAZARD

Enter the empty bin with extreme caution. Wear protective clothing, and a properly filtered respirator mask. Connect a safety line to yourself and have a responsible, trained person outside to assist in an emergency.

5.1 CONCRETE SLAB INSPECTION

Check the foundation conditions regularly. Cracks that are more than 1/8 inch wide in the concrete slab indicate significant movement.

Always consult with a professional engineer when foundation problems arise. If severe cracking exists, slab levels should be taken to determine whether any area of the slab is sinking independently.

Subsoil conditions should be monitored to ensure against bearing capacity losses.

5.2 BIN INSPECTION

1. Check that the bin lid is not obstructed and can be opened fully.

NOTICE

IMPLOSION HAZARD
Ventilation prevents a vacuum from forming during unloading, which may cause the bin to implode.

2. Inspect all seams.
3. Tighten all bolts to their specific torques.
4. Use the loading hatch to visually check inside the bin.
5. When the bin is empty, use the bottom manway in the hopper cone to enter for inspection and cleaning purposes.

Section 6: REFERENCE

For information not included here, or for a digital copy of this manual, please call your dealer, or Meridian Manufacturing Inc. directly for assistance. Visit our website at: www.meridianmfg.com.

6.1 BIN SPECIFICATIONS

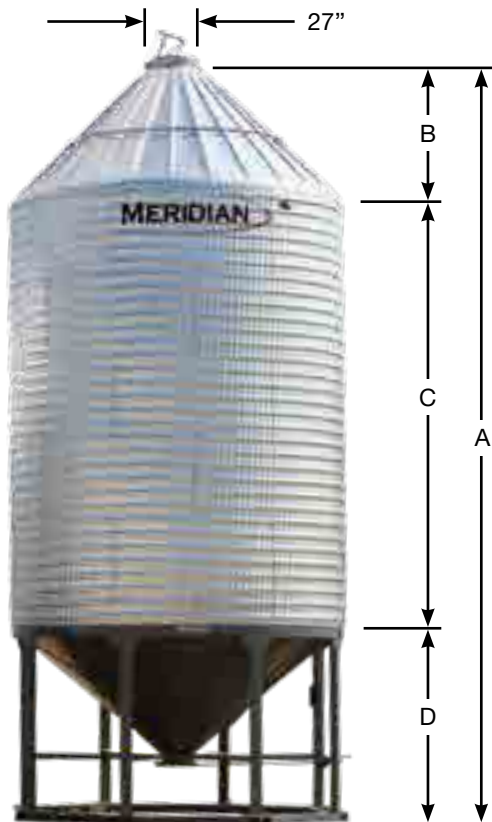

Fig 23 - 1605 DC Pictured



Fig 24 - 2406 SC Pictured

1605 DC



5
Rings of
Wall Sheets



DOUBLE
CORRUGATED

2406 SC



6
Rings of
Wall Sheets



SINGLE
CORRUGATED

Table 3 - Corrugated Hopper Combo Bins

Hopper Combo	Bushel Capacity	Diameter	Overall Height (A)	Roof Height (B)	Wall Height (C)	Cone/Skid Height (D)	Bin Weight	Cone/Skid Weight	Overall Weight	Auger Requirement *
1505 SC	3,342	15'	30' 8"	4' 5"	18' 11"	7' 4"	2,986 lb	3,970 lb	6,956 lb	59'
1506 SC	3,909	15'	34' 5"	4' 5"	22' 8"	7' 4"	3,616 lb	3,970 lb	7,586 lb	59'
1604 DC	3,548	15' 10"	31' 5"	7' 4"	16' 3-1/2"	7' 9"	2,880 lb	4,090 lb	6,970 lb	59'
1605 DC	4,170	15' 10"	35' 2"	7' 4"	20' 0-1/2"	7' 9"	3,585 lb	4,090 lb	7,675 lb	59'
1805 SC	4,874	18'	32' 11"	5' 1"	18' 11"	8' 6"	3,567 lb	4,680 lb	8,247 lb	59'
1806 SC	5,690	18'	36' 8"	5' 1"	22' 8"	8' 6"	5,421 lb	5,000 lb	10,421 lb	66'
2105 SC	6,804	21'	35' 1"	6' 2"	18' 11"	9' 8"	4,270 lb	7,260 lb	11,530 lb	66'
2106 SC	7,914	21'	38' 10"	6' 2"	22' 8"	9' 8"	5,360 lb	7,260 lb	12,620 lb	66'

Table 4 - Corrugated Split Hopper Combo Bins

Hopper Combo	Bushel Capacity	Diameter	Overall Height (A)	Roof Height (B)	Wall Height (C)	Cone/Skid Height (D)	Bin Weight	Cone/Skid Weight	Overall Weight	Auger Requirement *
2406 SC	10,498	24'	41' 1"	7' 2"	22' 8"	10' 10"	6,213 lb	9,750 lb	15,963 lb	66'
2706 SC	13,643	27'	43' 5"	8' 3"	22' 8"	12' 1"	7,801 lb	11,900 lb	19,701 lb	72'

* Auger length is based on level ground. If ground slopes away from bin it needs to be taken into consideration

WARRANTY STATEMENT

1. Meridian Manufacturing Inc, hereafter referred to as Meridian, guarantees its products against any defects in materials or workmanship for a period of twelve (12) months from the date of purchase, provided that the said products are set up according to its instructions and recommendations and also that the said products are operated and used in proper conditions and according to its instructions and recommendations.
2. Meridian's responsibility and obligations under this warranty shall be limited to replacement of parts and shall not extend to parts, equipment or accessories that are component parts of Meridian's products but that are manufactured by other manufacturers. Those manufacturers' warranty will apply to such parts, equipment or accessories. Any parts set up by reason of the application of this warranty shall be amenable to the terms of this warranty except that the period of twelve (12) months applicable to such parts shall be preemptory and that upon termination of the said period, warranty shall be null and void, for any purpose whatsoever with respect to the said parts substituted to it before the termination of the said period of twelve (12) months.
3. This warranty shall not extend to loss and damage to content of the products, neither to property or loss of revenue. Moreover, it shall not extend to bodily injuries, including death, sustained by any person or animal.
4. The purchaser shall give notice to Meridian, without delay, of any damage or defects to its products that he may ascertain before they are set up, otherwise this warranty will not apply to such damage or defects.
5. Any modification or incorporation whatsoever made to products, except those authorized or recommended by Meridian, shall void this warranty; this warranty shall not apply to damages resulting from improper installation or erection of products by purchaser.
6. This warranty is the sole and only warranty and it is in lieu of any other warranty, express or implied, statutory or not.
7. Any claim under this warranty shall be notified in writing to Meridian's head office within thirty (30) days from the failure.

Specifications and descriptions are subject to change without notice.

Register your product at: www.meridianmfg.com
For warranty information send an email to: warranty@meridianmfg.com

WARRANTY REQUEST PROCEDURE

1. The product must be registered with Meridian Manufacturing Inc.
2. The purchaser must contact the dealer, from where the unit was purchased, immediately upon discovery of any defects.
3. A completed Warranty Request (Claim) Form must be submitted by the dealer to the Meridian's warranty representative for review and any subsequent course of action.
 - Warranty requests must be completed with ALL required information in order it to be considered for approval.
 - Send photographs of the entire piece of equipment, and of the specific area of concern.
4. Warranty repair work will only be performed by Meridian or an approved representative of Meridian. Warranty work completed prior to Meridian's approval will NOT be honoured. Failure to follow this procedure may affect any or all of this warranty.
5. All warranty requests will be adjudicated at the sole discretion of Meridian and in accordance with the terms and conditions of the warranty.



Camrose, AB: (800) 830-2467
Lethbridge, AB: (800) 661-1436
Winkler, MB: (800) 665-7259
www.meridianmfg.com | galvanized@meridianmfg.com