



SAFETY AND OPERATION'S MANUAL



SLMD SERIES AUGER

SLMD10 • SLMD12 • SLMD14



www.meridianmfg.com

DECLARATION OF CONFORMITY

We the Manufacturer:

**Meridian Manufacturing Inc.
PO Box 1996 2800 Pasqua Street North
Regina, Sk, Canada
S4P 3E1**

Declare the Augers listed below conform to the 2006/42/EC Machinery Directive

SLMD 10 - SLMD 12 - SLMD 14

The Meridian Swing Drive Auger and Tube Assembly is designed for the movement of Grains and Cereals.

PATENT INFORMATION



Meridian continuously enhances its product offering through product improvements and new product innovations. Marketplace feedback, technological innovation, new materials and manufacturing methods, and a philosophy of continuous improvement constantly challenge the company to develop new and better ways of addressing market needs. Meridian is committed to innovation and reinvestment and as a result, the company maintains a portfolio of patents and intellectual property. For more information on our patents please see our website: www.meridianmfg.com/patents

TABLE OF CONTENTS

GENERAL

A1	Declaration of Conformity
A2	Table of Contents
A3	Sign Off Sheet

SAFETY

B1	Safety Symbols
B2	Safety & General
B3	Equipment Safety Guidelines
B4	Safety Training & Safety Signs
B5	Preparation
B6	Operating Safety
B7	Maintenance & Lockout/Tag Out Safety
B8	Required Tools for Assembly & Maintenance
B9	Safety Alert Symbols
B10	Designated Work Area
B11	Transport & Placement
B12	Safety Guard Description
B13	Safety Sign Locations

OPERATIONS

C1	Start Up and Break In
C2	Lubrication and Maintenance
C3	Grease Locations

WARRANTY

D1	Limited Warranty Statement
----	----------------------------

INFORMATION

E1	Information
----	-------------

SAFETY SYMBOLS

This Safety Alert Symbol means:
ATTENTION! BECOME ALERT!
YOUR SAFETY IS INVOLVED!



The Safety Alert Symbol identifies important safety messages on the Meridian Equipment and in the manual. When you see this symbol, be alert to the possibility of personal injury or death. Follow the instructions in the safety message.

Why is SAFETY important to you?

3 Big Reasons:

Accidents Disable and Kill
Accidents Cost
Accidents Can Be Avoided

SIGNAL WORDS:

Note the use of the signal words **DANGER**, **WARNING** and **CAUTION** with safety messages. The appropriate signal word for each message has been selected using the following guide-lines.

DANGER:

Indicates an imminently hazardous situation that, if not avoided, will result in death or serious injury. This signal word is to be limited to the most extreme situation typically for machine components which, for functional purpose, cannot be guarded.

WARNING:

Indicates a potentially hazardous situation that, if not avoided, could result in death or serious injury and includes hazards that are exposed when guards are removed. It may also be used to alert against unsafe practices.

CAUTION:

Indicates a potentially hazardous situation that, if not avoided, may result in minor or moderate injury. It may be used to alert against unsafe practices.

Failure to read this Transport Equipment Manual and its Safety Instructions is a misuse of the equipment.

If you have any questions not answered in the manual, require additional copies or the manual is damaged, please contact your dealer or Meridian Manufacturing Inc.

PO Box 1996 2800 Pasqua Street North, Regina SK, S4P 3E1
1-800-667-5904 (T) 1-306-545-4216 (F) www.meridianmfg.com

SAFETY & GENERAL SAFETY

SAFETY

YOU are responsible for the **SAFE** operation and maintenance of your Meridian Equipment. You must ensure that you and anyone else who is going to operate, maintain or work around the equipment be familiar with the operation and maintenance procedure and related **SAFETY** information contained in this manual.

Remember, **YOU** are the key to safety. Good safety practices not only protect you but also the people around you. Make these practices a working part of your safety program. Be certain that **EVERYONE** operating this equipment is familiar with the recommended operation and maintenance procedures and follow the safety precautions. Most accidents can be prevented. Do not risk injury or death by ignoring good safety practices.

- Equipment owners must give operating instructions to operators or employees before allowing them to operate the machine, and at least annually thereafter.
- A person who has not read and understood all operating and safety instructions is not qualified to operate the machine. An untrained operator exposes themselves and bystanders to possible serious injury or death. Always be and stay alert to any possible unsafe operating or maintenance procedures or conditions.
- Do not modify the equipment in any way. Unauthorized modification may impair the function and/or safety of the components and systems and could affect the life of the equipment, possibly invalidate the warranty coverage.
- Think **SAFETY!** Work **SAFELY!**

GENERAL SAFETY

1. Read and understand the operator's manual and all safety signs before operating, maintaining, adjusting, or unplugging the equipment.
2. Have a first-aid kit available for use should the need arise and know how to use it.
3. Have a fire extinguisher available for use should the need arise and know how to use it.
4. Wear appropriate gear. The list includes but not limited to:

- A Hard hat
- Protective shoes with slip resistant soles
- Protective goggles, glasses or face shield
- Heavy gloves
- Protective clothing
- Respirator

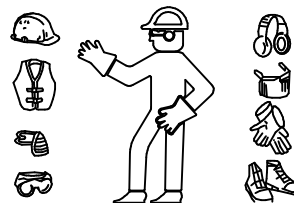

5. Install and secure all guards before starting.
6. Establish a Lock-out/Tag-out policy for work site. Be sure all personnel are trained and follow all procedures. Lock-out/Tag-out all power sources before entering bin or working around loading/unloading equipment.
7. Clear the area of people, especially small children, before starting.
8. Review safety related items annually with all personnel who will be using or maintaining the Equipment.

EQUIPMENT SAFETY GUIDELINES

1. Safety of the operator and bystanders is one of the main concerns in designing and developing a machine. However, every year many accidents occur which could have been avoided by a few seconds of thought and a more careful approach to handling equipment. You, the operator, can avoid many accidents by observing the following precautions in this section. To avoid personal injury or death, study the following precautions and insist those working with you, or for you, follow them.
2. In order to provide a better view, certain photographs or illustrations in this manual may show an assembly with a safety shield removed. However, equipment should never be operated in this condition. Keep all shields in place. If shield removal becomes necessary for repair, replace the shield prior to use.
3. Replace any safety sign or instruction sign that is not readable or is missing. See Safety Sign Locations for the locations of such safety signs.
4. Never use alcohol or drugs which can hinder alertness or coordination while operating the equipment. Consult your doctor about operating this machine while taking prescription medications.
5. Under no circumstances should your children be allowed to work with this equipment. Do not allow persons to operate or assemble this unit until they have read this manual and have developed a thorough understanding of the safety precautions and of how it works. Review the safety instructions with all users annually.
6. This Equipment is dangerous to children and persons unfamiliar with its operation. The operator should be a responsible, properly trained and physically able person familiar with farm machinery and trained in this equipment's operation. If the elderly are assisting with farm work, their physical limitations need to be recognized and accommodated. Never exceed the limits of a piece of machinery. If its ability to do a job, or to do so safely, is in question - DO NOT TRY IT!
7. Do not modify the equipment in any way. Unauthorized modifications can result in serious injury or death and may impair the function and life of the equipment.
8. In addition to the design and configuration of this implement, including Safety Signs and Safety Equipment, hazard control and accident prevention are dependent upon the awareness, concern, prudence and proper training of personnel involved in the operation, transport, maintenance and storage of the machine. Refer also to Safety message and operation instructions in each of the appropriate sections of the auxiliary equipment and machine manuals. Pay close attentions to the Safety Signs affixed to the auxiliary equipment and the machine.

SAFETY TRAINING & SAFETY SIGNS

SAFETY TRAINING

1. Safety is a primary concern in the design and manufacture of our products. Unfortunately, our effort to provide safe equipment can be wiped out by a single careless act of an operator or bystander.
2. In addition to the design and configuration of equipment, hazard control and accident prevention are dependent upon the awareness, concern, prudence and proper training of personnel involved in the operation, transport, maintenance and storage of this equipment.
3. It has been said, "The best safety feature is an informed, careful operator." We ask you to be that kind of operator. It is the operator's responsibility to read and understand ALL Safety and Operating instructions in the manual and to follow these. Accidents can be avoided.
4. Working with unfamiliar equipment can lead to careless injuries. Read this manual and the manual for your auxiliary equipment, before assembly or operating, to acquaint yourself with the machines. If this machine is used by any person other than yourself, it is the machine owner's responsibility to make certain that the operator, prior to operating:
 - a) Reads and understands the operator's manuals.
 - b) Is instructed in safe and proper use.
5. Know your controls and how to stop the auger, conveyors and any other auxiliary equipment quickly in an emergency. Read this manual and the one provided with your other equipment.
6. Train all new personnel and review instructions frequently with existing workers. Be certain only a properly trained and physically able person will operate the machinery. A person who has not read and understood all operating and safety instructions is not qualified to operate the machine. An untrained operator exposes themselves and bystanders to possible serious injury and death. If the elderly are assisting with farm work, their physical limitations need to be recognized and accommodated.



SAFETY SIGNS

1. Keep safety signs clean and legible at all times.
2. Replace safety signs that are missing or become illegible.
3. Replaced parts that previously displayed a safety sign should also display the current sign.
4. Safety signs are available from your authorized Distributor or Dealer Parts Department or the factory.

How to Install Safety Signs:

- Be sure that the installation area is clean and dry.
- Be sure temperature is above 50°F (10°C).
- Determine exact position before you remove the backing paper.
- Remove the smallest portion of the split backing paper.
- Align the sign over the specified area and carefully press the small portion with the exposed sticky backing in place.
- Slowly peel back the remaining paper and carefully smooth the remaining portion of the sign in place.
- Small air pockets can be pierced with a pin and smoothed out using the piece of sign backing paper.

PREPARATION

1. Never operate the Equipment and auxiliary equipment until you have read and completely understand this manual, the auxiliary equipment operator's manual, and each of the safety messages found on the safety signs on the equipment and auxiliary equipment.

2. Personal protection equipment including hard hat, safety glasses, safety shoes and gloves are recommended during assembly, installation, operation, adjustment, maintaining, repairing, removal, or moving the implement. Do not allow long hair, loose fitting clothing or jewelry to be around the equipment.

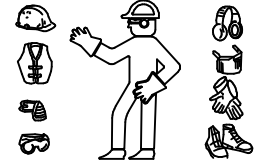

3. **PROLONGED EXPOSURE TO LOUD NOISE MAY CAUSE PERMANENT HEARING LOSS!**

The motor or equipment attached can often be noisy enough to cause permanent or partial hearing loss. We recommend that you wear hearing protection on a full-time basis if the noise in the operator's position exceeds 80db. Noise over 85db on a long-term basis can cause severe hearing loss. Noise over 90db adjacent to the operator over a long-term basis may cause permanent, total hearing loss.



NOTE: Hearing loss from loud noise (from tractors, chain saws, radios and other sources close to the ear) is cumulative over a lifetime without hope of natural recovery.

4. Clear area of debris, trash or hidden obstacles that might be hooked or snagged, causing injury, damage or tripping.

5. Operate only in daylight or good artificial light.

6. Be sure machine is properly anchored, adjusted and in good operating condition.

7. Ensure that all safety shields and safety signs are properly installed and in good condition.

8. Before starting, give the machine a look over for any loose bolts, worn parts, cracks, leaks, frayed belts and make necessary repairs. Always follow maintenance instructions.

OPERATING SAFETY

1. Make sure that anyone who will be operating the equipment or working on or around the unit read and understand all the operating, maintenance and safety information in the operator's manual.
2. Have another person nearby who can shut down the equipment in case of accident. It is good practice to always work with a second person around the equipment.
3. Do not operate with any safety shields removed.
4. Inspect the lift cable before using the equipment. Replace if frayed or damaged.
5. Ensure that equipment is empty before raising or lowering.
6. Operate equipment on level ground. Even though the equipment is connected to the tractor during operation, tipping can occur.
7. Keep hands, feet and clothing away from moving parts. Loose clothing can become entangled in rotating parts and cause serious injury.
8. Keep all bystanders, especially children, away from the equipment in use, or when authorized personnel are carrying out maintenance work.
9. Establish a Lock-out/Tag-out policy for work site. Be sure all personnel are trained in and follow all procedures. Lock-out/Tag-out all power sources before working around the equipment.
10. Review safety related items annually with all personnel who will be operating, using or maintaining the equipment.

MAINTENANCE & LOCK-OUT/TAG-OUT SAFETY

MAINTENANCE SAFETY

1. Good maintenance is your responsibility. Poor maintenance is an invitation to trouble.
2. Follow good shop practices.
 - Keep service area clean and dry.
 - Be sure electrical outlets and tools are properly grounded.
 - Use adequate light for job at hand.
3. Review safety related items annually with all personnel who will be operating, using or maintaining the equipment.
4. Use personal protection devices such as eye, hand, breathing and hearing protection, when performing any services or maintenance work.
5. A fire extinguisher and first aid kit should be kept readily accessible while performing maintenance on this equipment.
6. Periodically tighten all bolts, nuts and screws to ensure the unit is in safe condition.
7. When completing a maintenance or service function, make sure all safety shields and devices are installed before placing unit in service.



LOCK-OUT/TAG-OUT SAFETY

1. Establish a formal Lock-Out/Tag-Out program for you operation.
2. Train all operators and service personnel before allowing them to work around the equipment.
3. Provide tags at the work site and sign-up sheets to record tag out details.

REQUIRED TOOLS FOR ASSEMBLY & MAINTENANCE



HARD HAT



WORK GLOVES



SAFETY GLASSES



WRENCHES



EAR PROTECTION



WRENCH & SOCKETS



STEEL TOE WORK BOOTS



GREASE & OIL

SAFETY ALERT SYMBOLS



This symbol is used to call your attention to instructions concerning your personal safety. Watch for this symbol - it points out important safety precautions. It means "ATTENTION - Become Alert! Your Safety Is Involved!" Read the message that follows and be alert to the possibility of personal injury or death.

MACHINE INSPECTION

- Check to see that all guards listed in the assembly instructions are in place and secured, and functional.
- Check winch and cable for security and operation. There should be at least 3 complete wraps of cable around winch drum in full down position. Cable anchor on winch drum must be tight.
- Are all fasteners tight?
- Are all chains properly adjusted. (See Maintenance Section)
- Check oil levels in gear box. (See Maintenance Section)

OPERATOR QUALIFICATIONS

Operation of this transport equipment shall be limited to competent and experienced persons. In addition, anyone who will operate or work around portable equipment must use common sense. In order to be qualified, they must know and meet all other requirements, such as:

- Some regulations specify that no one under the age of 16 may operate power machinery. This includes augers and flight type elevators. It is your responsibility to know what these regulations are in your area or situation.
- Current OSHA regulations state in part: "At the time of initial assignment and at least annually thereafter, the employer will instruct **every** employee in the safe operation and servicing of all equipment with which the employee is, or will be involved."
- Unqualified persons are to **stay out** of the work areas.
- A person who has not read and understood all the operating and safety instructions is not qualified to operate the machine.

DESIGNATED WORK AREA

The following will show the designated work areas. These areas shall be marked off with colored nylon or plastic rope hung by portable barriers to define the designated work areas.

Under no circumstances should persons not involved in the operation of the equipment be allowed to trespass into the work area.

It shall be the duty of all operators to see that children and/or other persons stay out of the work area. Trespass into the area by anyone not involved in the actual operation, or trespass into a hazard area by anyone shall result in an immediate shutdown by the operator.

Prior to start up and during operation, it shall be the responsibility of the operators to see that the work area has secure footing, is clean and free from all debris and tools which may cause accidental tripping and/or falling

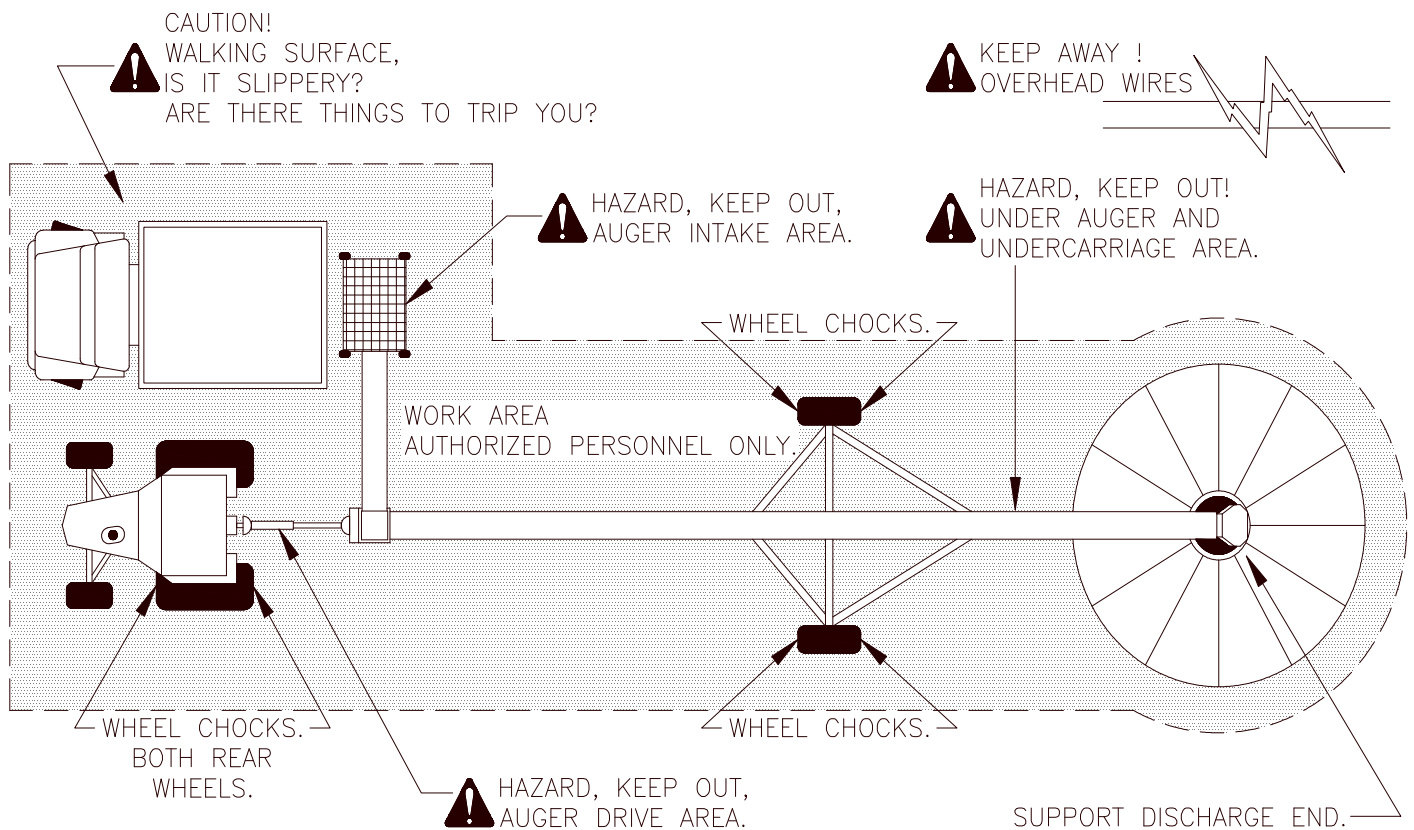

TRANSPORT AND PLACEMENT

MOVING THE AUGER WITH THE TOWING VEHICLE TO OR FROM THE WORK AREA

- Always transport your auger in the full down position. The Tube Assembly should be seated in the A-Frame cradle.
- Make sure that the hitch pin is securely attached and an alternate safety chain is secure to the auger and towing vehicle.
- Ensure Lift Arm Safety Chain is attached to the Hopper.
- Once the auger is hitched to the vehicle, ensure that the jack is swung up into the transport position
- Be alert of overhead obstructions and electrical wires. Electrocutation can occur without direct contact. Failure to do so will result in severe injury or death.
- Never allow persons to stand underneath or ride on the auger when it is being transported.

MOVING THE AUGER WITH THE TOWING VEHICLE INTO OR OUT OF ITS WORKING POSITION.

- Always move an auger with a vehicle, never manually.
- Lift slowly, no higher than hitch bar. Be sure grain is out of tube and auger is on level surface.
- Do not place lumber under wheels for increased height.
- Before raising, check for power lines.
- When auger is in place, anchor intake end and/or discharge end and chock wheels.
- When in transport or placement PTO shaft to be disconnected.



**OVERHEAD WIRES
KEEP AWAY!**

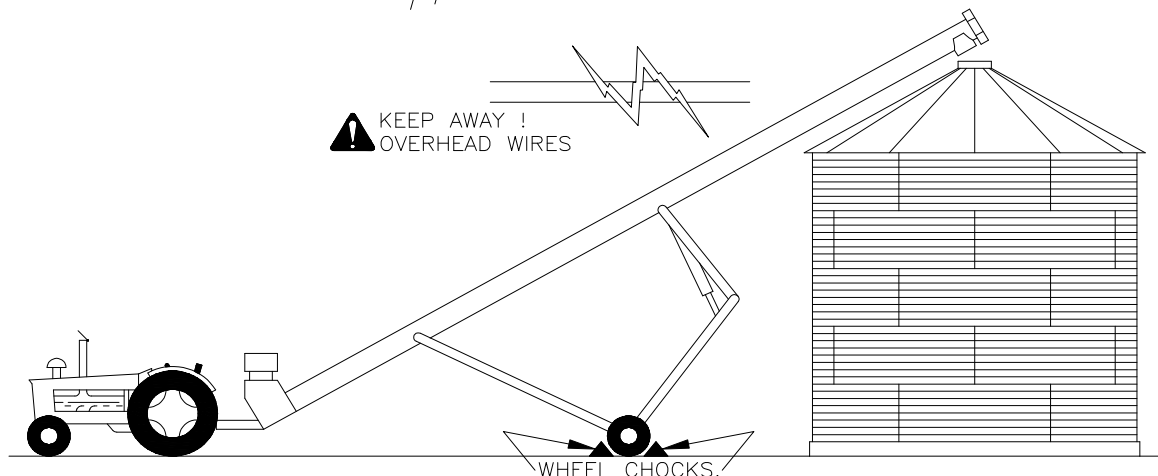
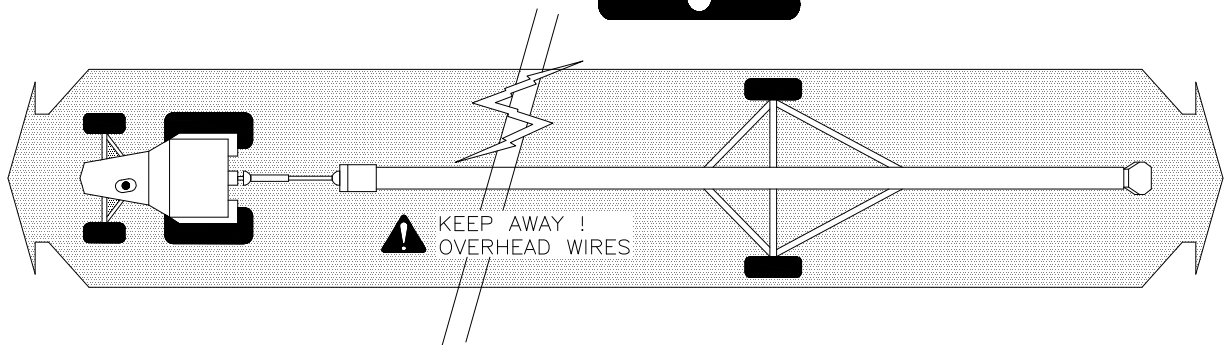

SAFETY GUARD DESCRIPTION

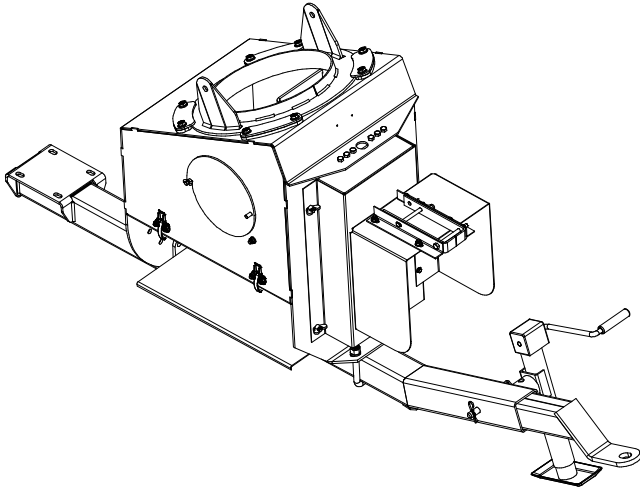

PTO DRIVE GUARD

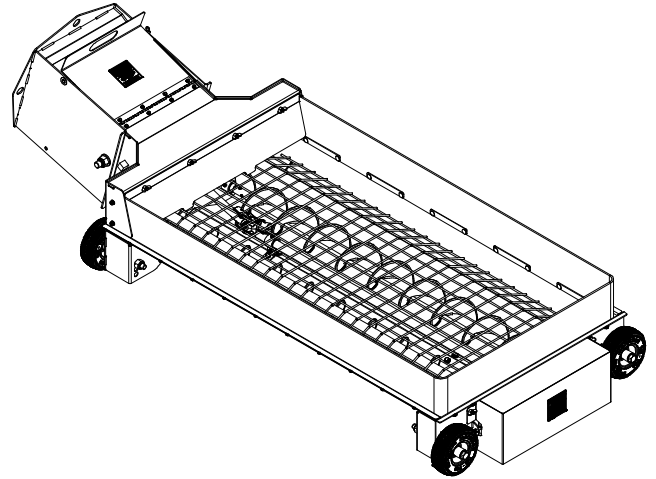

HOPPER FLIGHT GUARD

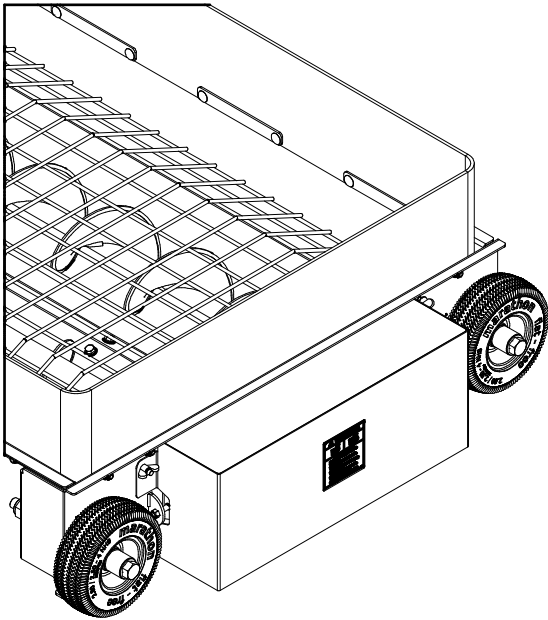

HOPPER DRIVE GUARD

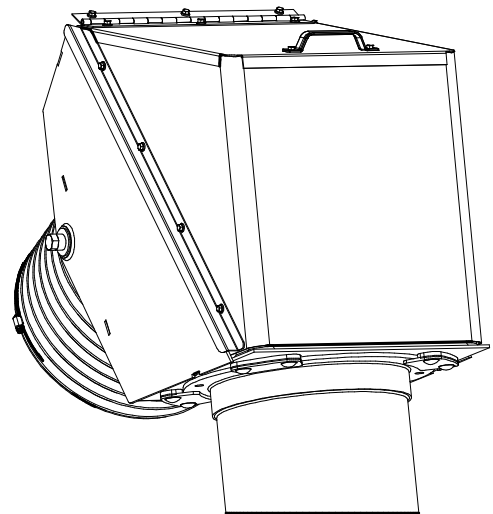

SWING HEAD GUARD

SAFETY SIGN LOCATIONS

⚠ CAUTION

1. Do not operate this auger before reading and understanding the operator's manual.
2. Do not operate this auger unless all guards and safety devices are securely in place.
3. Do not adjust, service, lubricate, clean, unclog or move this unit until all power has been shut off.
4. Make certain everyone is clear of the equipment before moving or operating. Never allow children, visitors or untrained personnel in the area.
5. Keep hands, feet and clothing clear of all moving parts while in operation.
6. Support discharge end or anchor intake end to prevent upending.
7. Empty auger and lower to transport position before moving to prevent upending.
8. Lower this unit to transport position when not in use.
9. When raising or lowering auger watch for overhead powerlines and other obstructions.
10. Disengage belt tension release on motor base before starting motor.
11. Disconnect power on electric motor driven units before resetting motor overload, make certain electric motors are properly grounded.
12. Always make certain that trained personnel are in attendance while unit is in operation.

⚠ WARNING



To Prevent Serious Injury or Death

- Avoid unsafe operation or maintenance.
- Do not operate or work on this machine without reading and understanding the operator's manual.
- If manual is lost, contact your nearest dealer for a new manual.

⚠ DANGER



Upending Hazard

The intake end of the grain auger must always have downward weight.

Always test it before releasing it from the vehicle or holddown.

Lift the intake slowly and keep it no higher than the tractor tow bar when attaching or releasing it.

Immediately lower the auger to transport position before moving.

Failure to do so will cause upending, which will result in serious injury or death.

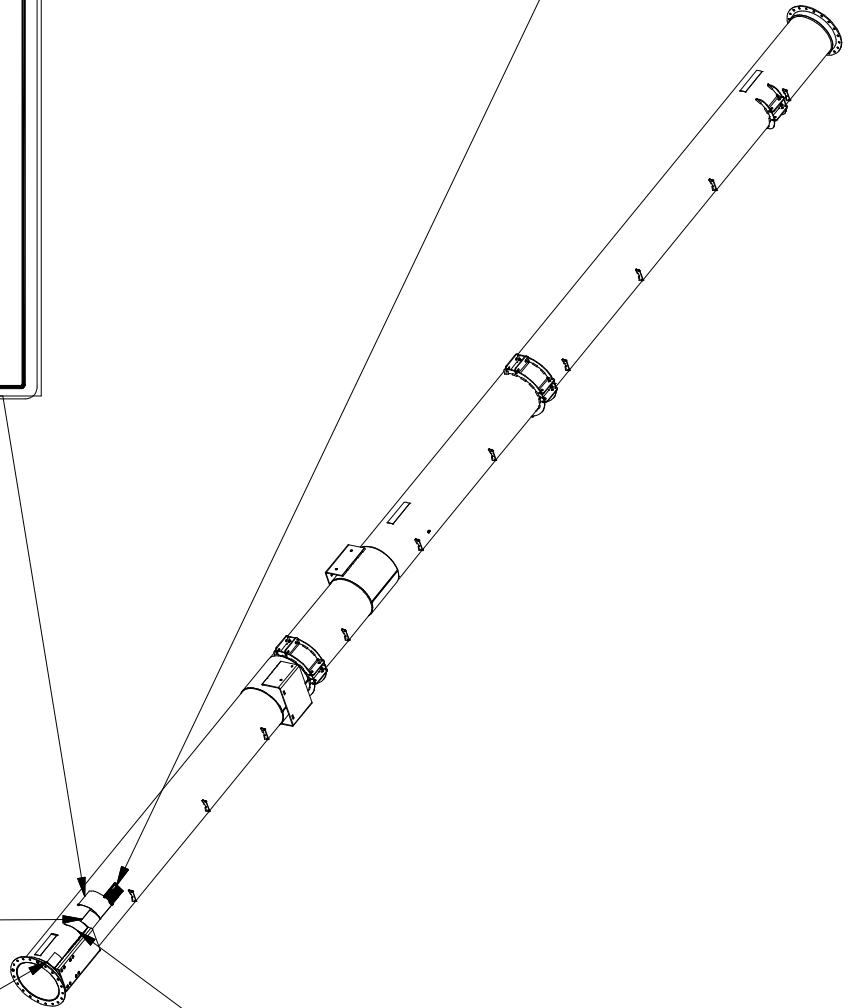

⚠ CAUTION

CLOSE VALVE IN THE LIFT CYLINDER HYDRAULIC LINE AFTER RAISING AUGER INTO POSITION

⚠ DANGER

ELECTROCUTION HAZARD



To prevent serious injury or death from electrocution:

- Stay away from overhead powerlines when transporting or raising augers. This machine is not grounded. Electrocution can occur without direct contact.

SAFETY SIGN LOCATIONS

CAUTION

P.T.O. OPERATION

- Connect C.V. end of P.T.O. to tractor.
- Do not exceed 25 degrees in either direction.
- Disconnect P.T.O. if angle exceeds more than 25 degrees during a tight turn.
- When moving or positioning auger always disconnect P.T.O. from tractor and place P.T.O. in holder.
- Failure to follow the above list will damage the C.V. joint.

3295

CAUTION

P.T.O. OPERATION

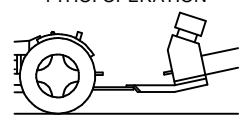

- Maintain 36" - 38" distance between tractor stub and auger stub by repositioning the adjustable auger hitch.
- Maintain a minimum 4" lap on tumbler shields.

3296

DANGER



ROTATING FLIGHTING
Keep away from intake end. Failure to do so will result in serious injury or death.

Do not use the auger without intake guard in place.

1657

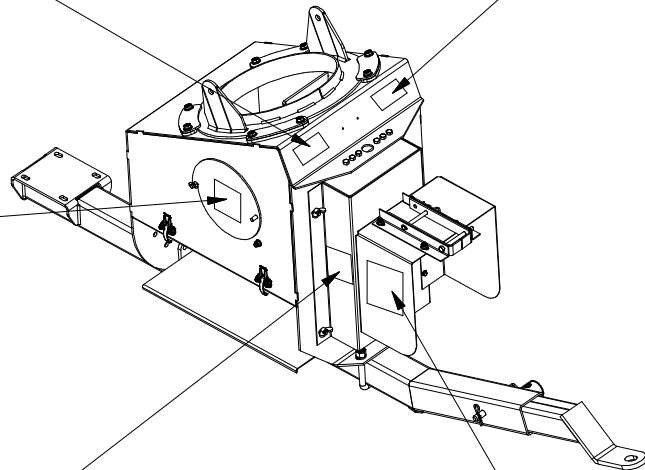

WARNING



MOVING PART HAZARD
To prevent serious injury or death from moving parts:

- Close and secure guards and shields before starting.
- Keep hand, feet, hair, and clothing away from moving parts.
- Disconnect and lockout power source before adjusting or servicing.
- Do not stand or climb on machine when operating.

1658

DANGER



ROTATING DRIVELINE
CONTACT CAN CAUSE DEATH
KEEP HANDS, FEET HAIR AND CLOTHING AWAY FROM MOVING PARTS

Do not operate without-

- All driveline, tractor and equipment shields in place.
- Drivelines securely attached at both ends.
- Driveline shields that turn freely on driveline.

1660

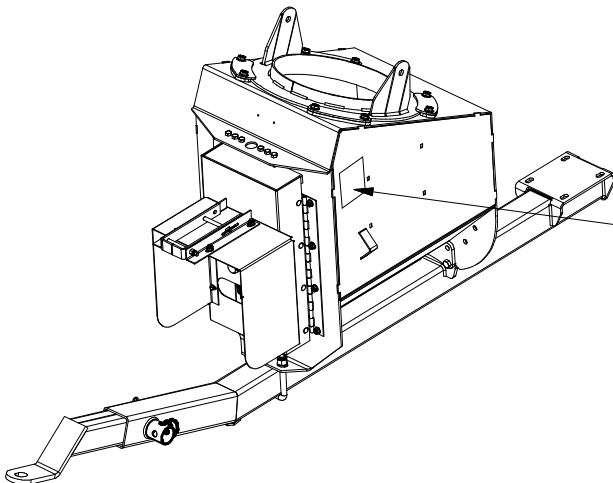

WARNING



HIGH PRESSURE FLUID HAZARD
To prevent serious injury or death

- Relieve pressure on system before repairing or adjusting or disconnecting.
- Wear proper hand and eye protection when searching for leaks. Use wood or cardboard instead of hands.
- Keep all components in good repair.

1716

SAFETY SIGN LOCATIONS

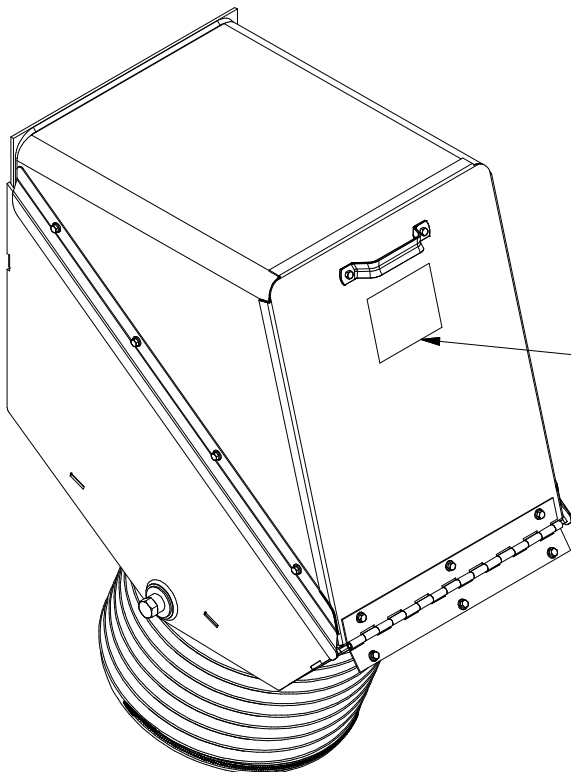
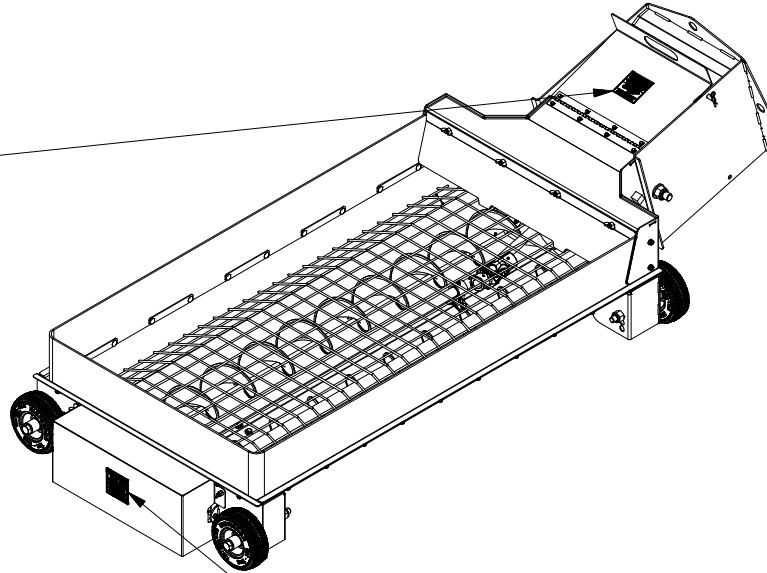

START UP AND BREAK IN

NEW AUGER START UP AND BREAK IN

Meridian Manufacturing Inc recommends that you do the following before augering grain with your new auger:

- Run the grain auger at approximately 1/2 the normal operating speed (see table 1.1) without adding grain to the intake for approximately 5 minutes.
- Bring auger up to full operation speed (see table 1.1) and slowly add grain to the hopper.
- Continue to add grain slowly until approximately 1000 bushels (28 tonnes) has been loaded through the grain auger. This will "shine up" the flighting and the tube.
- The operator should be aware of any unusual vibrations or noises, determine source and shut down. **LOCK OUT POWER SOURCE BEFORE SERVICING OR ADJUSTING.**

OLD AUGER START UP AND BREAK IN

Meridian Manufacturing Inc recommends that you do the following before augering grain with your used auger:

- Before positioning the auger, be sure all guards and shields are in place, securely fastened and fully operational.
- Check oil level in gear boxes, fill if necessary and lubricate all grease fittings.
- Ensure PTO shaft is securely fastened.
- Check the lift cable before each use and replace if frayed or damaged.

CAUTION

- Observe work area restrictions (see work area diagram)
- Keep all safety guards and shields in place.
- Make certain everyone is clear before operating or moving the machine.
- Keep hands and feet away from all moving parts.
- Lock out power source to adjust, service or clean.

EMERGENCY SHUT DOWN

- Should the auger be immediately shut down under load, lock out the power source and disconnect PTO shaft. Empty grain from hopper and auger. Starting the auger under load may result in damage to the grain auger.

- Before restarting, make certain everyone is clear of the designated work area.
- Start grain auger at a reduced speed.

NORMAL SHUT DOWN

- Make sure that the hopper and auger are empty before stopping the unit.
- Lock out power source and remove PTO shaft.

CLEAN UP AND STORAGE

When the operation is completed, it is recommended that you move the auger to the new work area or to a storage area.

- Remove barriers, anchors and wheel chocks. Clean entire work area.
- Remove PTO shaft and move auger slowly out of work area.
- Lower auger to full down position immediately upon clearance of any obstruction.
- The auger should be stored in the full down position.
- Do not attempt to pull grain auger out of snow bank in winter. This will cause damage to the tube assembly.
- Ensure that there is no snow build up on the auger tube while in storage to prevent damage to the auger.
- Store auger with the hopper in the tipped position.
- **CAUTION!** Maintain a minimum 4" lap on the tumbler shields. Do not engage power take-off until all personnel are clear of tractor, tumbler shaft and auger. Ensure ends are fastened securely to the auger and tractor.
- When installing PTO, ensure CV end goes to tractor

AUGER SIZE	SPEED (rpm)
SLMD 10	450
SLMD 12	450
SLMD 14	450

TABLE 1.1. Operating speeds

LUBRICATION AND MAINTENANCE

DANGER! Do not service or lubricate while the auger is running. **LOCK OUT THE POWER SOURCE!**

GEAR BOX

- Fill gear box with #90 gear oil quantity as per chart:

AUGER SIZE	QUANTITY
SLMD 10	1/2 L
SLMD 12	1/2 L
SLMD 14	1/2 L

- Do not overfill gear box.
- Change oil once a year.
- Grease U-Joint once a day.
- SLMD 14 has extra gearbox reducer by the boot.

HEAD END

- The bearings are pre-lubricated at the factory and have grease fittings for future lubrication.

HOPPER

- All hopper bearings are pre-lubricated and do not require further lubrication.
- Grease U-Joint and bushings once daily.
- Grease hopper wheels once every season.

HOPPER LIFT

- Cable rollers should be oiled once a season.

DRIVE CHAIN

- Drive chains should be oiled with #130 gear oil once every season.

PTO SHAFT

- PTO shaft and attachment should be greased once a day with a good quality grease.

GREASE LOCATIONS

		GEASE LOCATIONS	
		Location	QTY
BOOT	Flight Bearing Ect	6	
	Lower Gear Box	1	
HEAD END	Lower U-Joint	1	
	Upper Gear Box	0	
	Upper U-Joint	1	
HOPPER	Flight-Feed Tube	1	
	Flight U-Joint	1	
	Throat Flight Hanger	1	
	Flight Hangers	2	
	Drive Shaft U-Joint	1	
	Drive Shaft Hanger	1	
	Wheels	4	
FRAME	Main A-Frame	2	
	Rest Tube Frame	4	
	Main Cylinder	1	
TUBE	Top Flight Bearing	1	
PTO	Auger-Tractor	2	

Limited Warranty Statement

1. Meridian Manufacturing Inc warrants each new Meridian Manufacturing Inc product (the "Goods") to be free from defects in material and workmanship under normal use and service for a period of two (2) years or ninety (90) days in the case of commercial use, from the shipment date from the Meridian dealer (FCA).
2. Meridian warrants replacement parts and components either manufactured or sold by, will be free from defects in materials or workmanship under normal use and service for thirty (30) days from the shipment date from the Meridian dealer (FCA), or the remainder of the original warranty period on the Goods, whichever is longer.
3. This warranty does not apply to:
 - a) to any merchandise or components thereof, which in the sole and unfettered opinion of Meridian, have been subject to misuse, unauthorized modifications, alteration, accident, negligence, product abuse or lack of required maintenance.
 - b) if repairs have been made with parts or by persons other than those parts or persons approved by Meridian.
 - c) to parts and accessories not manufactured by Meridian including, but not limited to, engines, batteries, tires, belts, PTO shafts or other trade accessories. Such parts shall be covered by the warranty given by the actual manufacturer, if any.
 - d) to failure of parts; or failure of parts to perform due to wear under normal or excessive service conditions; or to failure due to use by the Purchaser for purposes other than originally intended at time of manufacture, including without limitation using the Goods for mixing fertilizer, etc.; or used in excess of the built specifications.
 - e) to Goods used in areas exposed to corrosive or aggressive conditions including, but not limited to, salt water from either inside or outside the Goods.
 - f) to failures or defects arising out of damage during shipment or during storage.
 - g) to materials replaced or repaired under this warranty, except to the extent of the remainder of the applicable warranty.
4. The obligation of Meridian under this warranty shall not arise unless Meridian is notified and this warranty is presented together with a written statement specifying the claim or defect within thirty (30) days after the failure is first detected or made known to the Purchaser and within: (i) two (2) years, or ninety (90) days in the case of commercial use; or (ii) thirty (30) days in the case of replacement parts and components manufactured by Meridian; from the shipment date from the Meridian dealer (FCA). Meridian in its sole and unfettered discretion shall determine if the claim is valid and whether correction of the defect or failure shall be made by repair or replacement of the materials.
5. Title to any replaced materials Meridian wishes to have pass to it, shall pass to Meridian.
6. The obligation of Meridian hereunder extends only to the original Purchaser or Buyer to whom the Goods were initially sold. This warranty shall not be subject to any assignment or transfer without the written consent of Meridian.
7. The purchaser acknowledges that it has made its own independent decision to approve the use of the Goods and also the specific fabrication and construction procedures utilized to complete the Goods, and has satisfied itself as to the suitability of these products for its use.

8. This warranty is subject to the following limitations, provisions and conditions:
- a) Meridian shall have no liability hereunder for any claims, including field re-work.
 - b) Meridian shall not be liable for any incidental loss or damage, however caused, including, without limitation, normal wear and tear.
 - c) Meridian makes no express or implied warranties of any nature whatsoever except for such express warranties as set out herein. The warranty provided herein is in lieu of and excludes all other warranties, guarantees or conditions pertaining to the Goods, written or oral, statutory, express or implied, (except the warranty as to title) including any warranty as to the merchantability or fitness for any particular purpose. Meridian expressly disclaims all other representations, conditions or warranties, expressed or implied, statutory or otherwise and any representations, warranties or conditions that may arise from a course of dealing or usage of trade. The warranty provided herein shall constitute Meridian's sole obligation and liability and the Purchaser's sole remedy for breach of warranty. No other warranty has been made by any employee, agent, or representative of Meridian and any statements contained in any other printed material of Meridian is expressly excluded herefrom. Meridian shall not be responsible for any warranty offered by the Purchaser to its customers with respect to the Goods and the Purchaser shall indemnify Meridian with respect to same if any of those customers makes a claim against Meridian relating to any such warranty.
 - d) Subject to Meridian's obligations contained in paragraphs 1 and 2 herein, none of Meridian, its officers, directors, servants or agents shall be liable, or responsible for any loss or damage (including strict liability and liability for loss or damage due to items which the manufacturing processes are designed to identify) whether such loss or damage is caused by negligence in any manner whatsoever (including gross negligence, error, misrepresentation, misstatement, imprudence, lack of skill or lack of judgement).
9. The sole financial obligation of Meridian under this warranty shall be limited to the repair or replacement of the Goods as originally supplied and in no event shall they exceed the original cost of the Goods supplied.
10. Meridian shall not have any obligation under any warranty herein until all accounts have been paid in full by the Purchaser.
11. The construction and interpretation of this Warranty shall be governed by the laws of the Province of Saskatchewan.

Warranty Claim Procedure

- 1. Purchaser must register the Goods with Meridian.
- 2. Purchaser must contact the dealer where the unit was purchased from upon discovery of any defects.
- 3. A completed warranty claim form must be submitted by the dealer to Meridian's warranty representative for review and any subsequent course of action.
- 4. Warranty repair work will only be performed by Meridian or an approved representative of Meridian. No warranty work completed prior to approval by Meridian will be honored. Failure to follow procedure may affect any or all of this warranty.
- 5. Claims will be adjudicated at the sole discretion of Meridian and in accordance with the terms and conditions of the limited warranty.

Meridian Augers is committed to providing the best and most complete line of grain handling and storage products in the industry to you. We appreciate and thank you for your continued support and we look forward to being of continued service to you.

Please contact your Dealer for a Parts and Assembly Manual

www.meridianmfg.com

MERIDIAN MANUFACTURING INC.

With over 65 years of experience,
Meridian is your storage and handling expert.



www.meridianmfg.com

Cambridge Office

605 Sheldon Dr.
Cambridge, On. N1T 2K1
PH: 519.620.6004
TF: 855.346.3712
FX: 519.620.6041

Camrose Office

4232 - 38 St.
Camrose, AB T4V 4B2
PH: 780.672.4516
TF: 800.830.2467
FX: 780.672.4759

Lethbridge Office

3125 - 24 Ave. N.
Lethbridge, AB T1H 5G2
PH: 403.320.7070
TF: 800.661.1436
FX: 403.320.7579

Regina Office

PO Box 1996
Regina, SK S4P 3E1
PH: 306.545.4044
TF: 800.667.5904
FX: 306.545.4216

Storm Lake Office

2902 Expansion Blvd.
Storm Lake, IA 50588
PH: 712.732.1780
TF: 800.437.2334
FX: 712.732.1028

Winkler Office

Box 760, 275 Hespler Ave.
Winkler, MB R6W 4A8
PH: 204.325.7883
TF: 800.665.7259
FX: 204.325.5556