



# ASSEMBLY AND PARTS LIST MANUAL



## CONVENTIONAL AUGER

TL10-33 • TL10-39

# DECLARATION OF CONFORMITY

We the Manufacturer:

**Meridian Manufacturing Inc.  
PO Box 1996 2800 Pasqua Street North  
Regina, Sk,Canada  
S4P 3E1**

Declare the Augers listed below conform to the 2006/42/EC Machinery  
Directive

TL10-33  
TL10-39

WFN 3607 & 3608

The Meridian TL10 Series Belt Drive Screw Conveyor and Tube Assembly  
is designed for the movement of Grains and Cereals.

# TABLE OF CONTENTS

## **GENERAL**

- A1 Declaration of Conformity
- A2 Table of Contents
- A3 Sign Off Sheet

## **ASSEMBLY**

- B1 Main Frame & A-Frame Assembly
- B2 Tube Assembly
- B3 Belt Drive Assembly

## **PARTS**

- C1 Head - End Assembly
- C2 Gear Box Assembly
- C3 33' Main Frame Assembly
- C4 39' Main Frame Assembly
- C5 33' A-Frame Assembly
- C6 39' A-Frame Assembly
- C7 33' Tube Assembly
- C9 39' Tube Assembly
- C11 Motor Mount Assembly
- C13 PTO Attachment
- C14 PTO Assembly
- C15 Winch Assembly
- C16 General Parts

## **INDEX**

- D1 Parts Index

## **WARRANTY**

- E1 Warranty and Disclaimer



# FRAME ASSEMBLY

NOTE: Reference to right and left hand used throughout this manual refers to the position standing at the intake end looking toward the head-end.

## A-FRAME ASSEMBLY

1. Lay out the frame as shown in **Fig 1**
2. Install spindles in frame using the last or bottom holes in the A-Frame.
3. Place A-Frame so the stub on the Main Frame axle can be slid into the second hole on the A-Frame. Now do the same on the other side. Both pieces should be installed on the axle and be pointing in the opposite direction. (**Fig 1**)
4. Install A-Frame cross brace on A-Frame.
5. Mount gooseneck to the A-Frame, using the middle holes on the gooseneck and the upper end of A-Frame.
6. Install track roller brackets and track roller as shown in **Fig 2**. (do not tighten)
7. When assembling swing augers, install lift cable roller at the upper end of gooseneck.
8. Mount tires on rims and mount rims on axle spindles.

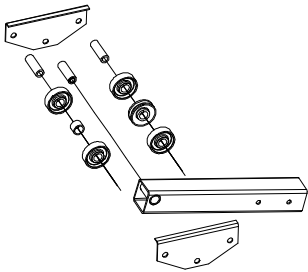

FIGURE 2

## MAIN FRAME ASSEMBLY

1. Lay frame out as shown in **Fig 1**
2. Fasten Main Frame to axle using 7/16" dia. bolts. (do not tighten)
3. Install Main Frame to axle braces and Main Frame cross brace at the same time.
4. Install winch base plate and belt idler bracket.
5. Bolt on winch.
6. Fasten battery mount.
7. Assemble cable roller bracket and mount frame.
8. Leave out two bolts on winch plate so Main Frame can be spread apart to fit on tube pins.

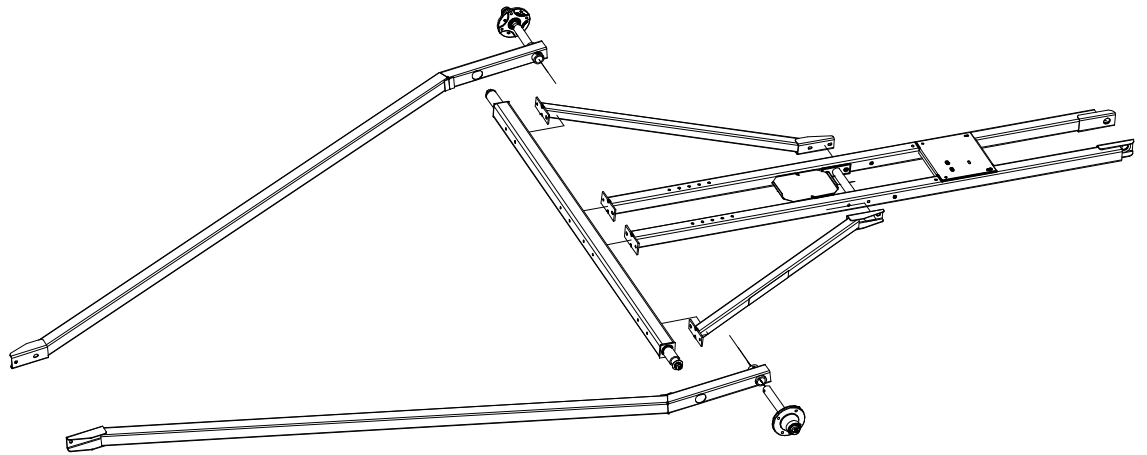

FIGURE 1

# TUBE ASSEMBLY

## ASSEMBLY

1. Tube assembly has been pre-assembled at the factory, at this time you should check the tube for damage.
2. After checking for damage, this is a good time to grease drive shaft bearings and oil head-end chains. Head-end bearings have been prelubricated.

## INSTALLATION

1. Raise head-end of the auger tube about 5 ft. Position the complete frame under the auger tube. Place A-Frame to head-end, and Main Frame to intake end. At this time you should run the cable around the grooved roller on the gooseneck.
2. Lift A-Frame up to head-end of the track on the bottom of the auger tube. Spread track roller brackets and fit over track, then tighten.
3. Make sure that the track rollers are well lubricated and rotate freely.
4. Now raise the head-end of the auger tube high enough to allow the Main Frame to fit on the steel pins of the tube assembly. These are the same pins that the truss cable eyebolts are mounted to.
5. Roll frame back to allow the frame to line up to the tube assembly. Then tighten all the bolts on the complete frame and insert all other frame bolts.
6. Lower the auger to the ground and allow the A-Frame to rest against the track stop.
7. Attach cable to the bottom track stop with cable clamp. Cable will already be threaded through the cable roller in the gooseneck (done in previous step). The cable then runs around the Main Frame cable roller and then to the winch. Allow 3 wraps of cable around the winch drum before cable is tight.
8. A regular belt drive auger is complete except for safety guards (engine pulley guard and base plate, gear box pulley guard). Also make sure all other guards and shields are in place and secure for your safety.

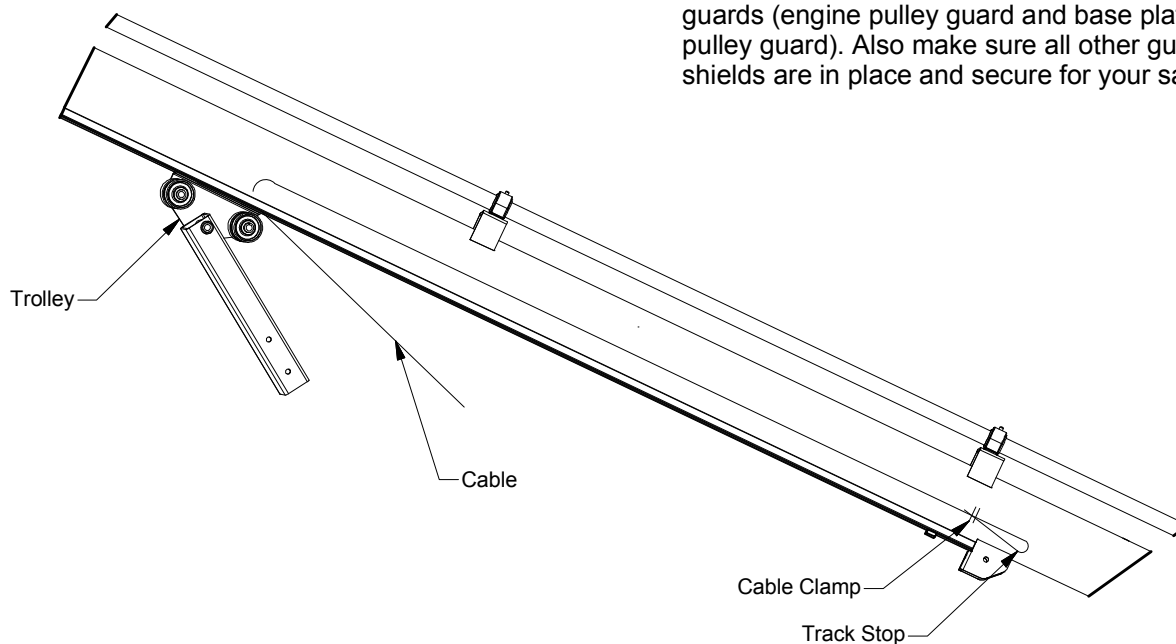

# BELT DRIVE ASSEMBLY

1. Mount PTO base onto motor mount base (leave bolts loose).
2. Bolt guard mounting brackets to PTO base on the side that has bolt holes. The small end of the bracket bolts onto the PTO base.
3. Bolt the guard base to the large end of the brackets.
4. Take the V-pulley in the PTO kit and mount it on the gear box of the main auger tube. Hub of the V-pulley must face into gear box.
5. Take the old V-pulley from the gear box and mount it on the PTO shaft of the PTO base. Face the hub of the V-pulley into the PTO base.
6. Bolt guard cover onto guard base.
7. Slide splined coupler onto PTO drive shaft and then tighten the screws.
8. Bolt cover guard to V-pulley guard.

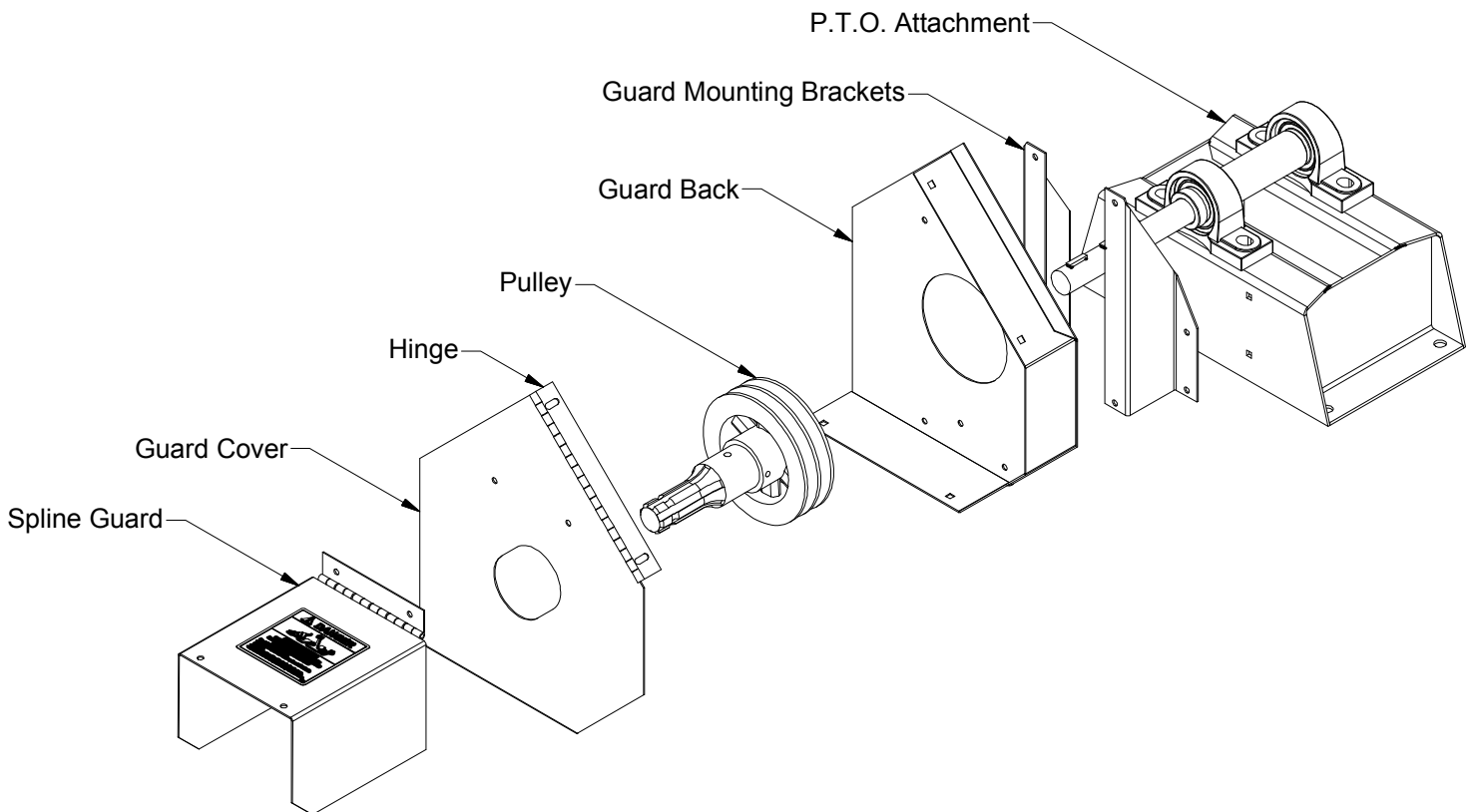

# HEAD - END

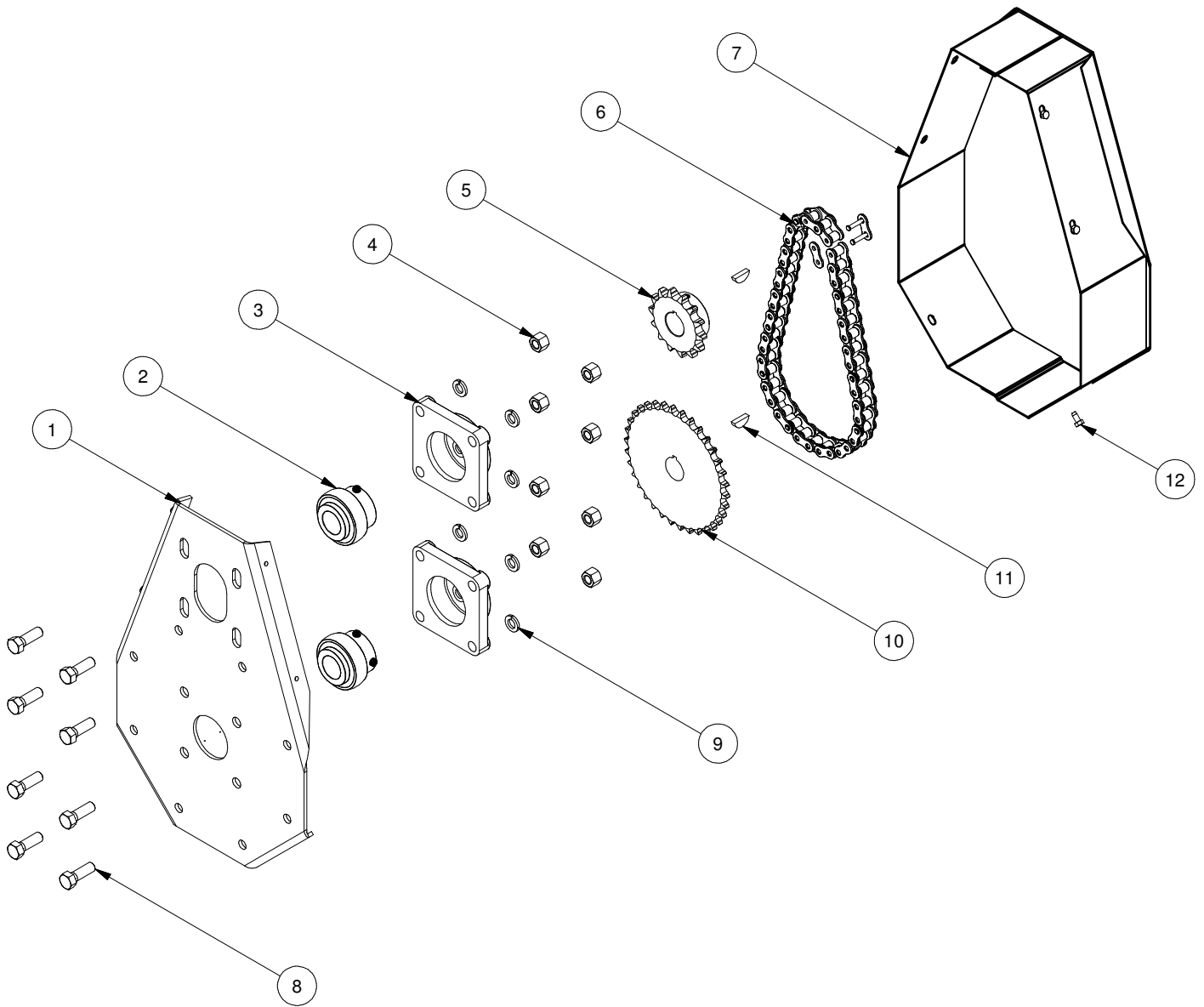

TL10			
REF #	PART #	QUANTITY	DESCRIPTION
1	13000002838-00	1	Base Plate
2	13000001456-00	AS REQ'D	1 1/4" ID Ball Bearing Insert
3	13000002511-00	2	1 1/4" Ball Bearing Insert c/w Housing
4	13-0725-00008	8	Hex Nut 1/2"-13 UNC
5	13000001668-00	1	Sprocket - 60B14 - 1.25" Hardened
6	13000002719-00	1	60B-45 c/w Connecting & Offset Link
7	13000002841-00	1	Head End Cover
8	13-0702-08024	8	Bolt 1/2"-13 UNC - 1.5
9	13-0734-00008	8	Spring Lock Washer 1/2"
10	13000002340-00	1	Sprocket - 60B34 - 1.25" Hardened
11	11-0740-00808	2	Woodruff Key 808
12	13-0707-04012	6	1/4" x 3/4" Self Tapping Screw



## GEAR BOX

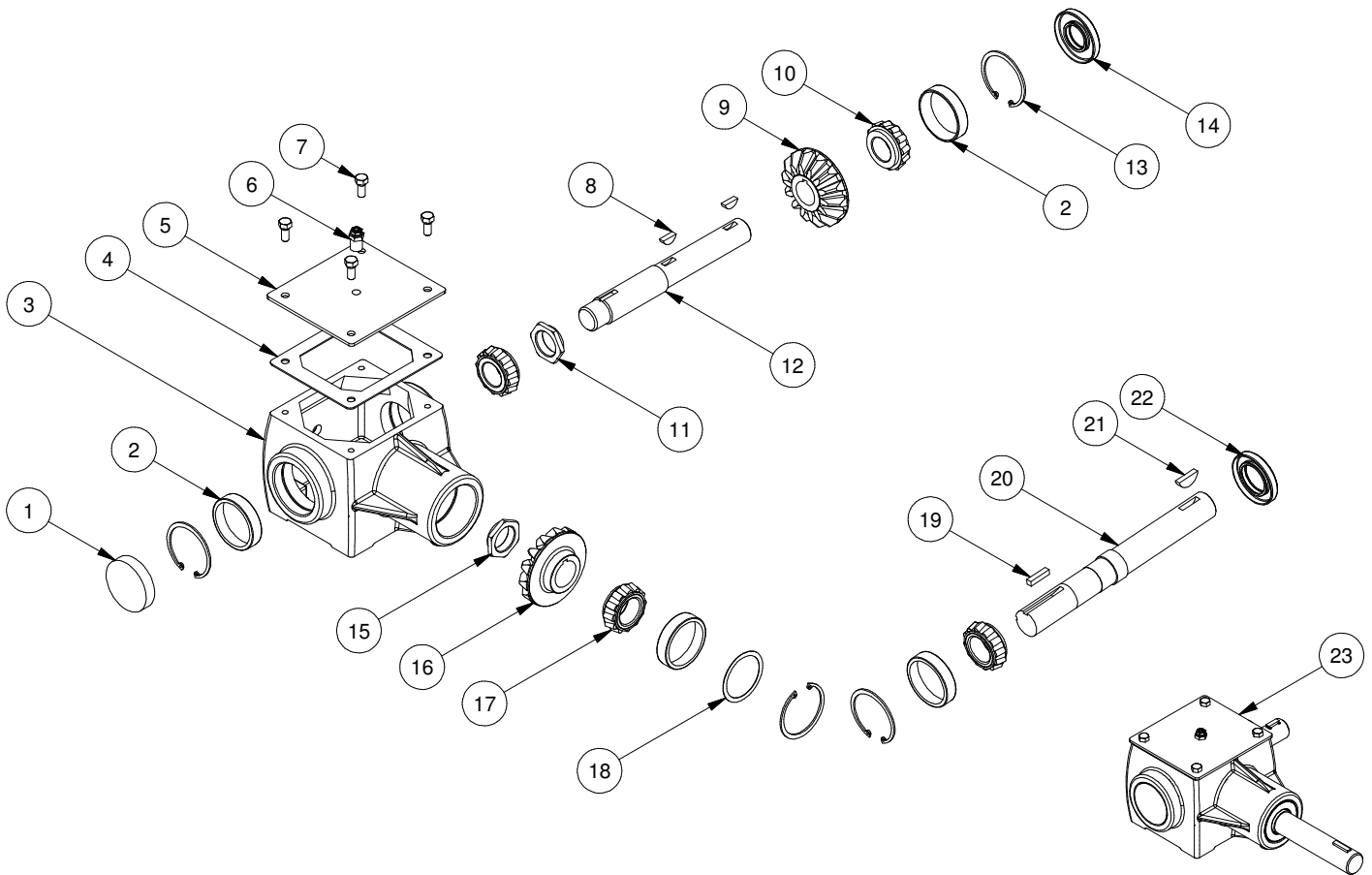

TL10			
REF #	PART #	QUANTITY	DESCRIPTION
1	13000001092-00	1	Cap
2	13000001089-00	4	Tapered Roller Bearing - Cup
3	13000001086-00	1	Gear Box Housing
4	13000001085-00	1	Cover Gasket
5	13000001084-00	1	Gear Box Cover
6	13000001083-00	1	Vent Plug & Bushing
7	13-0702-05012	4	Bolt 5/16-18 UNC - 0.75
8	11-0740-00808	2	Woodruff Key No. 808
9	13000001093-00	1	Bevel Gear - 1 1/8" Bore
10	13000001088-00	2	Tapered Roller Bearing - Cone
11	13000001094-00	1	Adjusting Nut - 1-1/8 in x 18 Thread
12	13000002959-00	1	Output Shaft
13	13000001091-00	4	Snap Ring
14	13000001095-00	1	Oil Seal - 1 1/8" ID
15	13000001204-00	1	1 1/4" - 18 THD Stakenut
16	13000001208-00	1	Bevel Gear - 1 1/4" Bore
17	13000001207-00	2	Tapered Roller Bearing 1 1/4" - Cone
18	13000001090-00	AS REQ'D	Shim
19	13000004637-00	1	Key - Square 1/4" x 1/4" x 1 1/8"
20	13000002957-00	1	Input Shaft
21	13-0740-00809	1	Woodruff Key No. 809
22	13000001494-00	1	Oil Seal - 1 3/8" ID
23	13000002858-00	1	Gear Box Complete

PARTS

# MAIN FRAME - TL10-33

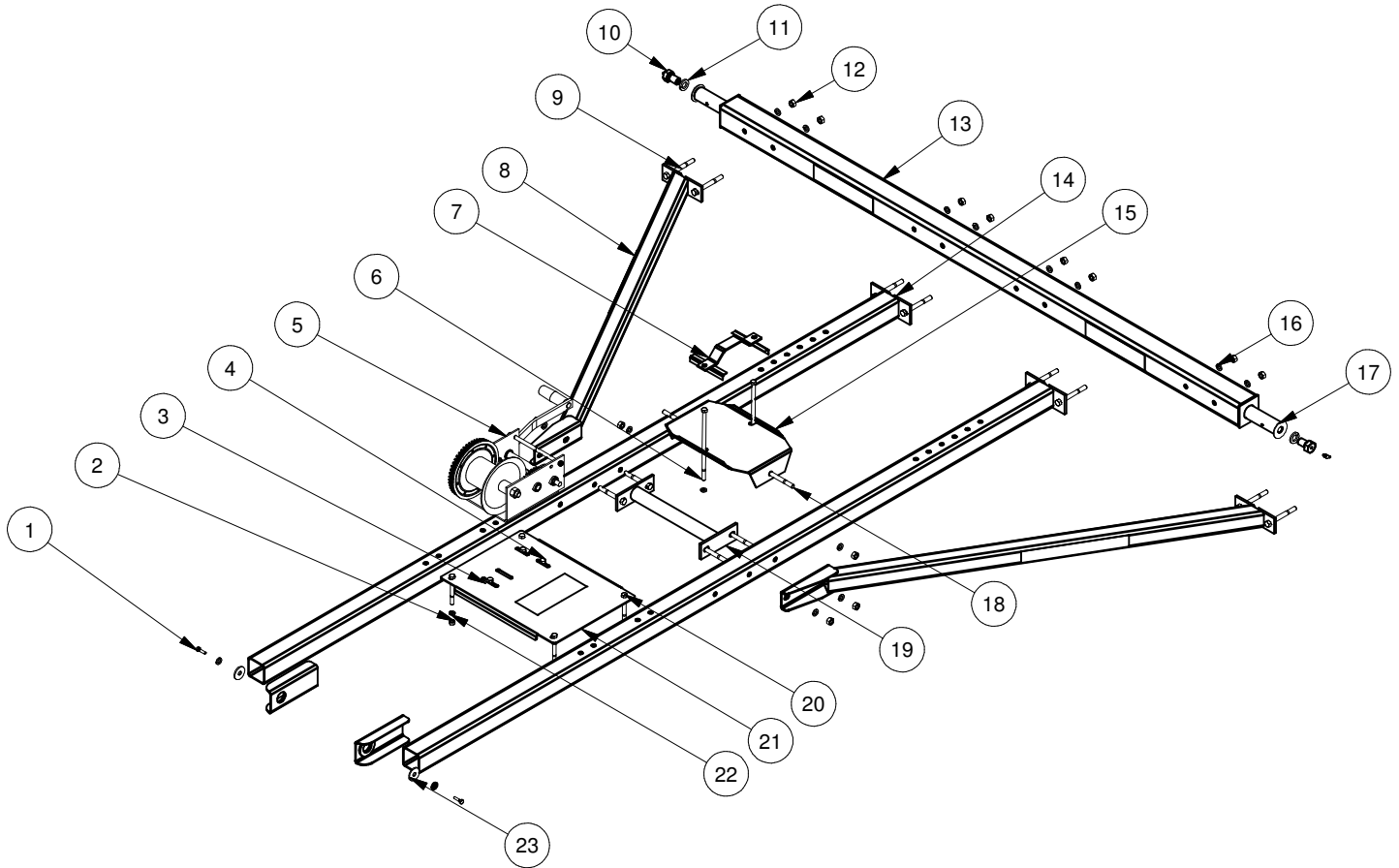

TL10-33			
REF #	PART #	QUANTITY	DESCRIPTION
1	13-0702-04016	2	Hex Cap Screw 1/4-20 UNC - 1
2	13-0702-06056	4	Hex Cap Screw 3/8-16 UNC 3.5
3	13-0731-00006	3	Flange Nut 3/8-16 UNC
4	13-0702-06016	3	Hex Cap Screw 3/8-16 UNC - 1
5	13000001681-00	1	K-2550 Fulton Winch
6	13-0702-06144	2	Hex cap Screw 3/8-16 UNC - 9
7	13000001924-00	1	Battery Top Mount
8	13000002372-00	2	Axle Brace Assembly
9	13-0702-07064	8	Hex Cap Screw 7/16-14 UNC - 4
10	13000001926-00	2	Zerk Bolt Assembly
11	13-0734-00012	2	Spring Lock Washer 3/4"
12	13-0725-00007	14	Hex Nut 7/16" - 14
13	13000002840-00	1	Axle
14	13000002354-00	2	Frame Main
15	13000001923-00	1	Battery Mount Base - 10"
16	13-0734-00007	16	Spring Lock Washer 7/16"
17	13-0735-00012	2	Flat Washer 3/4"
18	13-0702-07056	6	Hex Cap Screw 7/16-14 UNC - 3.5
19	13000003518-00	1	Cross Brace
20	13-0702-06056	4	Hex Cap Screw 3/8-16 UNC - 3.5
21	13000002892-00	1	Winch Base Plate
22	13-0734-00006	6	Spring Lock Washer 3/8
23	13000003117-00	2	Flat Washer - 7/16"

PARTS

# MAIN FRAME - TL10-39

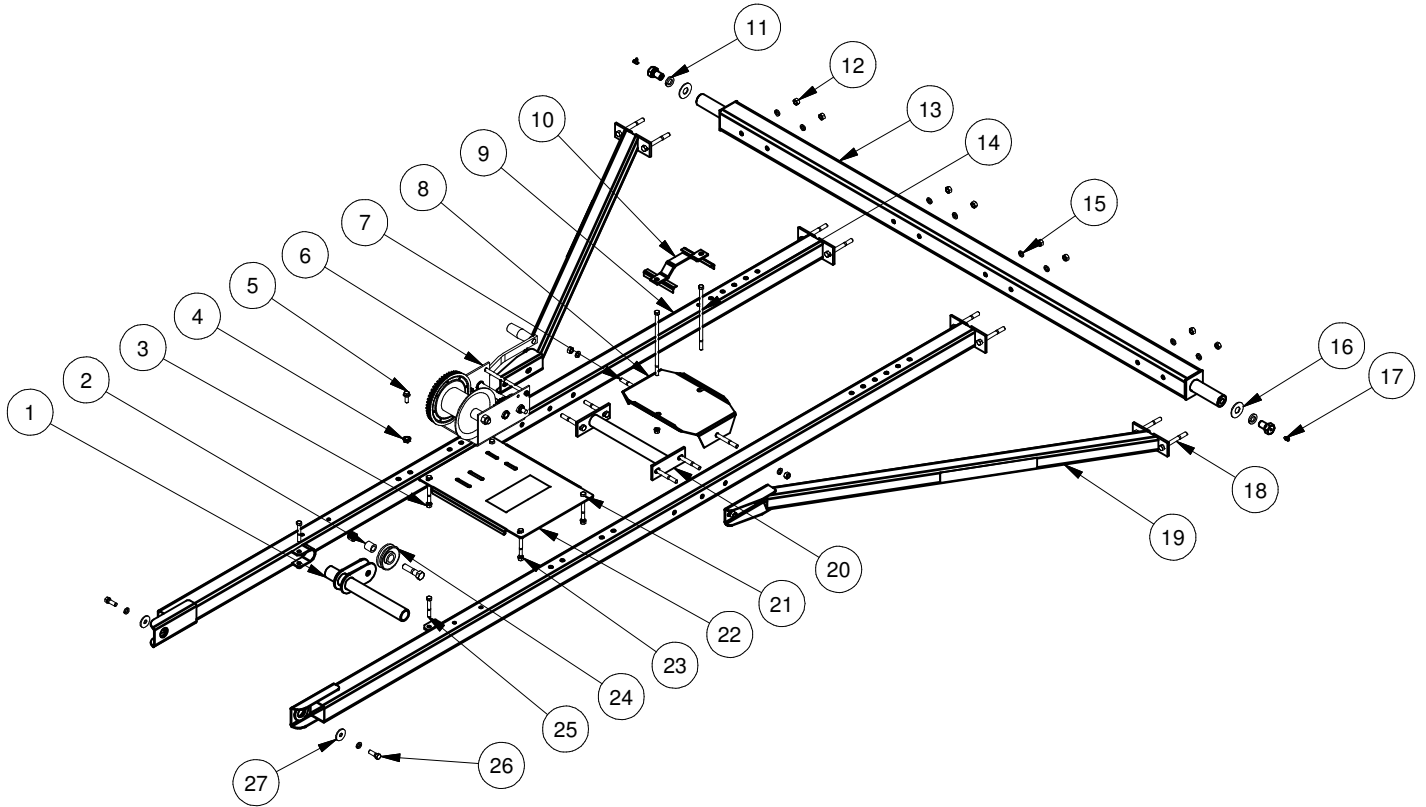

TL10-39			
REF #	PART #	QUANTITY	DESCRIPTION
1	13000001524-00	1	Bracket Cable Roller Assembly
2	13000001381-00	1	Cable Roller Bushing
3	13-0725-00006	8	Hex Nuts 3/8"
4	13-0731-00006	3	Flange Nut 3/8-16 UNC
5	13-0712-06016	3	Flange Bolt 3/8-16 UNC x 1
6	13000001681-00	1	K-2550 Fulton Winch
7	13-0702-07056	6	Hex Cap Screw 7/16-14 UNC - 3.5
8	13000001923-00	1	Battery Mount Base- 10"
9	13000002355-00	2	Frame Main
10	13000001924-00	1	Battery Top Mount
11	13-0734-00012	2	Spring Lock Washer - 3/4"
12	13-0725-00007	14	Hex Nut 7/16"
13	13000002840-00	1	Axle
14	13-0702-06144	2	Hex Cap Screw 3/8-16 UNC - 9
15	13-0734-00007	16	Spring Lock Washers - 7/16"
16	13-0735-00012	2	Flat Washer - 3/4"
17	13000001926-00	2	Zerk Bolt Assembly
18	13-0702-07064	8	Hex Cap Screw 7/16-14 UNC - 4
19	13000002372-00	2	Axle Brace Assembly
20	13000003518-00	1	Cross Brace
21	13-0702-06056	4	Hex Cap Screw 3/8-16 UNC - 3.5
22	13000002892-00	1	Winch Base Plate
23	13-0734-00006	8	Spring Lock Washers - 3/8"
24	13000001017-00	1	Cable Roller
25	13-0702-06040	2	Hex Cap Screw 3/8-16 UNC - 2.5
26	13-0702-07020	2	Hex Cap Screw 7/16-14 UNC - 1.25
27	13000003117-00	2	Flat Washer - 7/16"

PARTS

# A FRAME - TL10-33

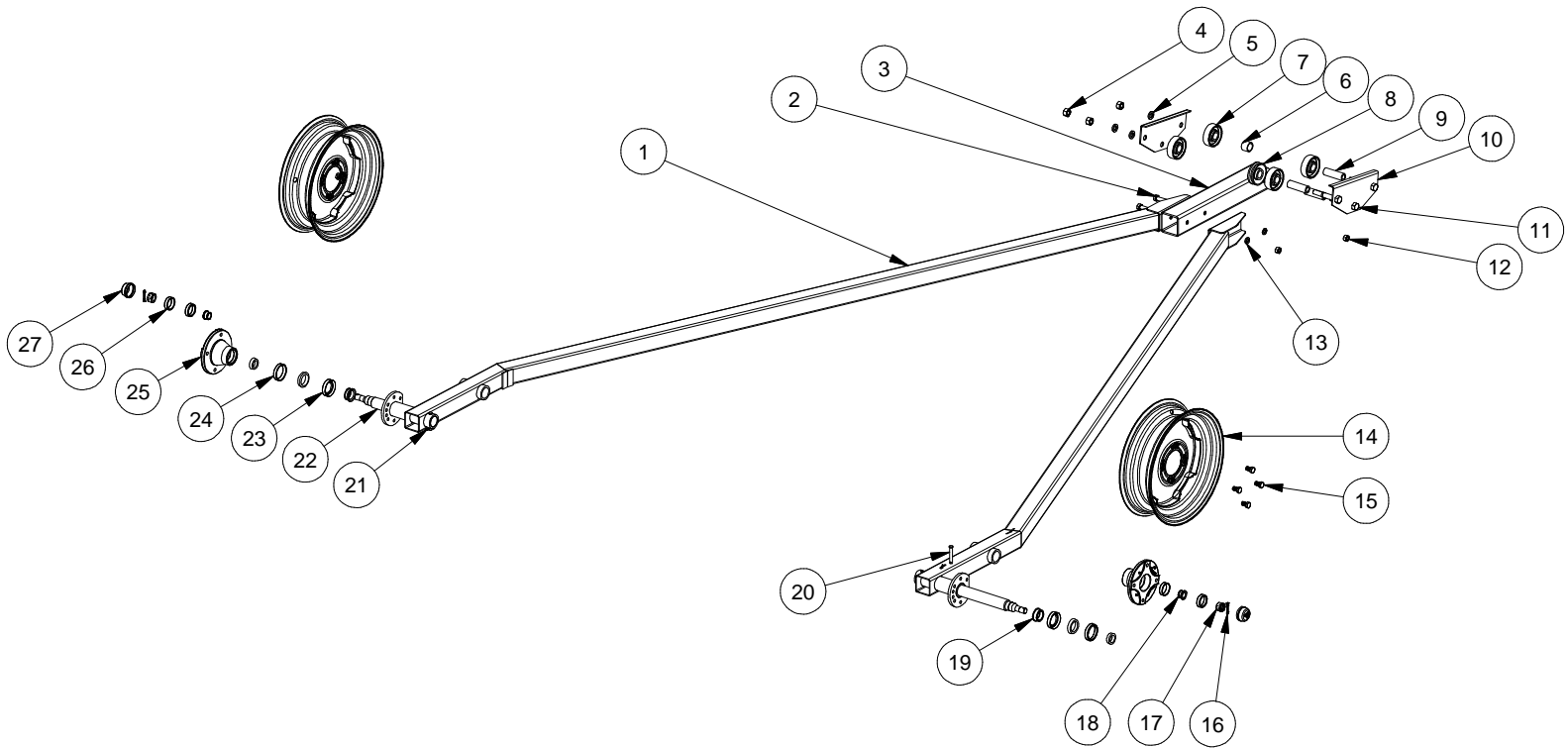

TL10-33			
REF #	PART #	QUANTITY	DESCRIPTION
1	13000005222-00	2	Frame A
2	13-0702-08064	2	Hex Cap Screw 1/2-13 UNC - 4
3	13000005026-00	1	Goose Neck
4	13-0725-00010	3	Hex Nuts 5/8" -11
5	13-0734-00010	3	Spring Lock Washers - 5/8"
6	13000001365-00	1	Spacer - Track Roller
7	13000001016-00	4	Track Roller
8	13000001017-00	1	Cable Roller
9	13000001364-00	3	Trolley Bearing
10	13000001366-00	2	Trolley Guide
11	13-0702-10064	3	Hex Cap Screw 5/8-11 UNC - 4
12	13-0725-00008	2	Hex Nuts 1/2 - 13
13	13-0734-00008	2	Spring Lock Washers - 1/2"
14	1223-00	2	15" WHEEL
15	13000001012-00	8	1/2" x 7/8" Wheel Stud
16	13-0737-05040	2	Cotter Pin 5/32 x 1 1/4"
17	13000001010-00	2	3/4" Castlated Nut
18	13000001009-00	2	Tapped Roller Bearing Cup (Outer)
19	13000001005-00	2	Tapered Roller Bearing Cone (Outer)
20	13000001387-00	2	Clevis Pin 3/8 x 2-3/8
21	13-0737-04032	2	Cotter Pin 1/8 x 1"
22	13000001670-00	2	1 1/2" x 13" Spindle
23	13000001004-00	2	Grease Seal
24	13000001006-00	2	Tapped Roller Bearing Cup (Inner)
25	13000001007-00	2	Hub
26	13000001008-00	2	Tapped Roller Bearing Cone (Outer)
27	13000001011-00	2	Dust Cap

PARTS

# A FRAME - TL10-39

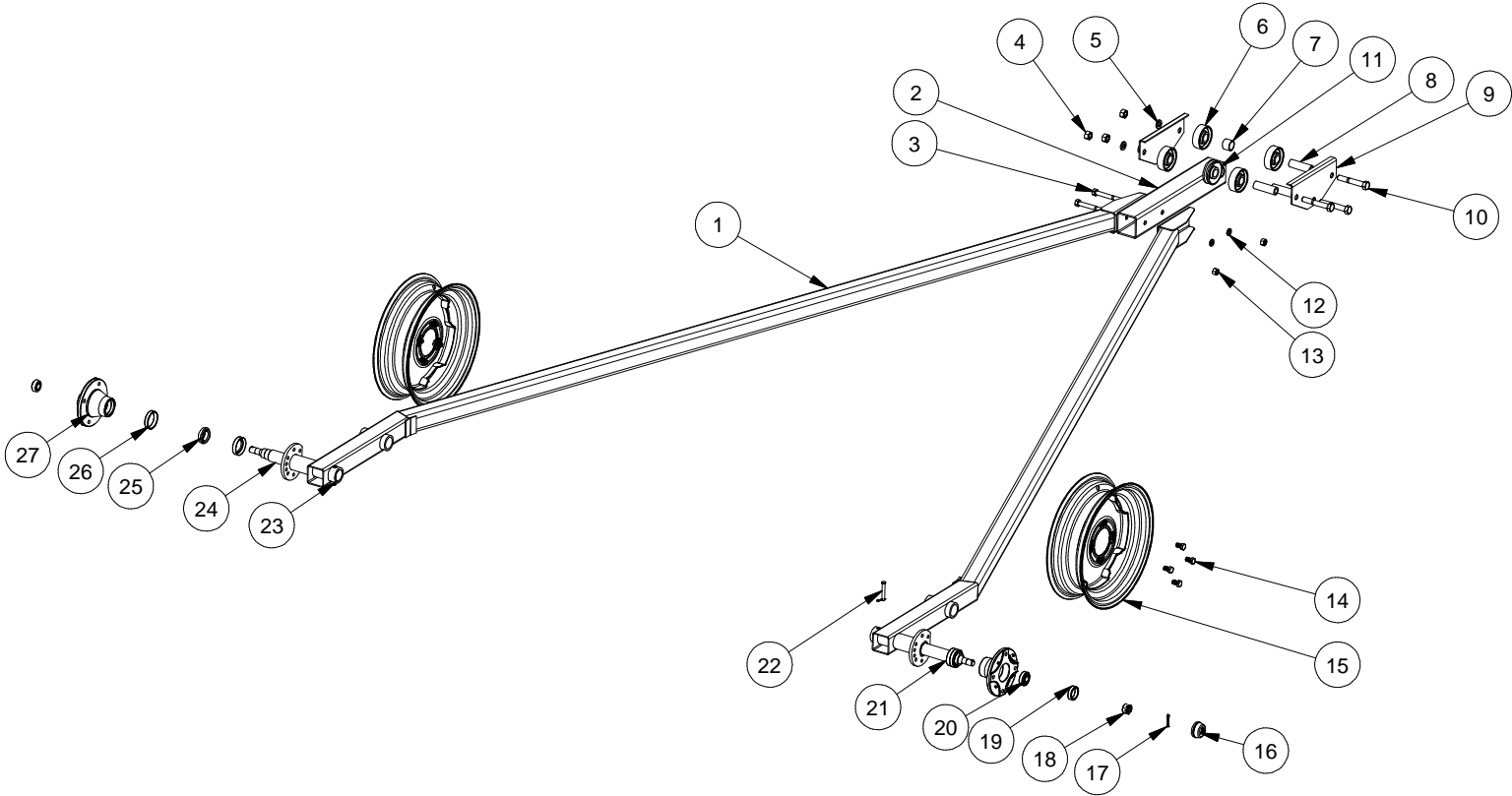

TL10-39			
REF #	PART #	QUANTITY	DESCRIPTION
1	13000005223-00	2	Frame A
2	13000005026-00	1	Goose Neck
3	13-0702-08064	2	Hex Cap Screw 1/2-13 UNC - 4
4	13-0725-00010	3	Hex Nuts - 5/8"
5	13-0734-00010	3	Spring Lock Washers -5/8"
6	13000001016-00	4	Track Roller
7	13000001365-00	1	Spacer - Track Roller
8	13000001364-00	3	Trolley Bearing
9	13000001366-00	2	Trolley Guide
10	13-0702-10064	3	Hex Cap Screw 5/8-11 UNC - 4
11	13000001017-00	1	Cable Roller
12	13-0734-00008	2	Spring Lock Washers - 1/2"
13	13-0725-00008	2	Hex Nuts -1/2"
14	13000001012-00	8	1/2" x 7/8" Wheel Stud
15	1223-00	2	15" WHEEL
16	13000001011-00	2	Dust Cap
17	13-0737-05040	2	Cotter Pin 5/32 x 1 1/4"
18	13000001010-00	2	3/4" Castlated Nut
19	13000001008-00	2	Tapped Roller Bearing Cone (Outer)
20	13000001009-00	2	Tapped Roller Bearing Cup (Outer)
21	13000001004-00	2	Grease Seal
22	13000001387-00	2	Clevis Pin 3/8 x 2-3/8
23	13-0737-04032	2	Cotter Pin 1/8 x 1"
24	13000001670-00	2	1 1/2" x 13" Spindle
25	13000001005-00	2	Tapered Roller Bearing Cone (Outer)
26	13000001006-00	2	Tapped Roller Bearing Cup (Inner)
27	13000001007-00	2	Hub

# TUBE ASSEMBLY - TL10-33

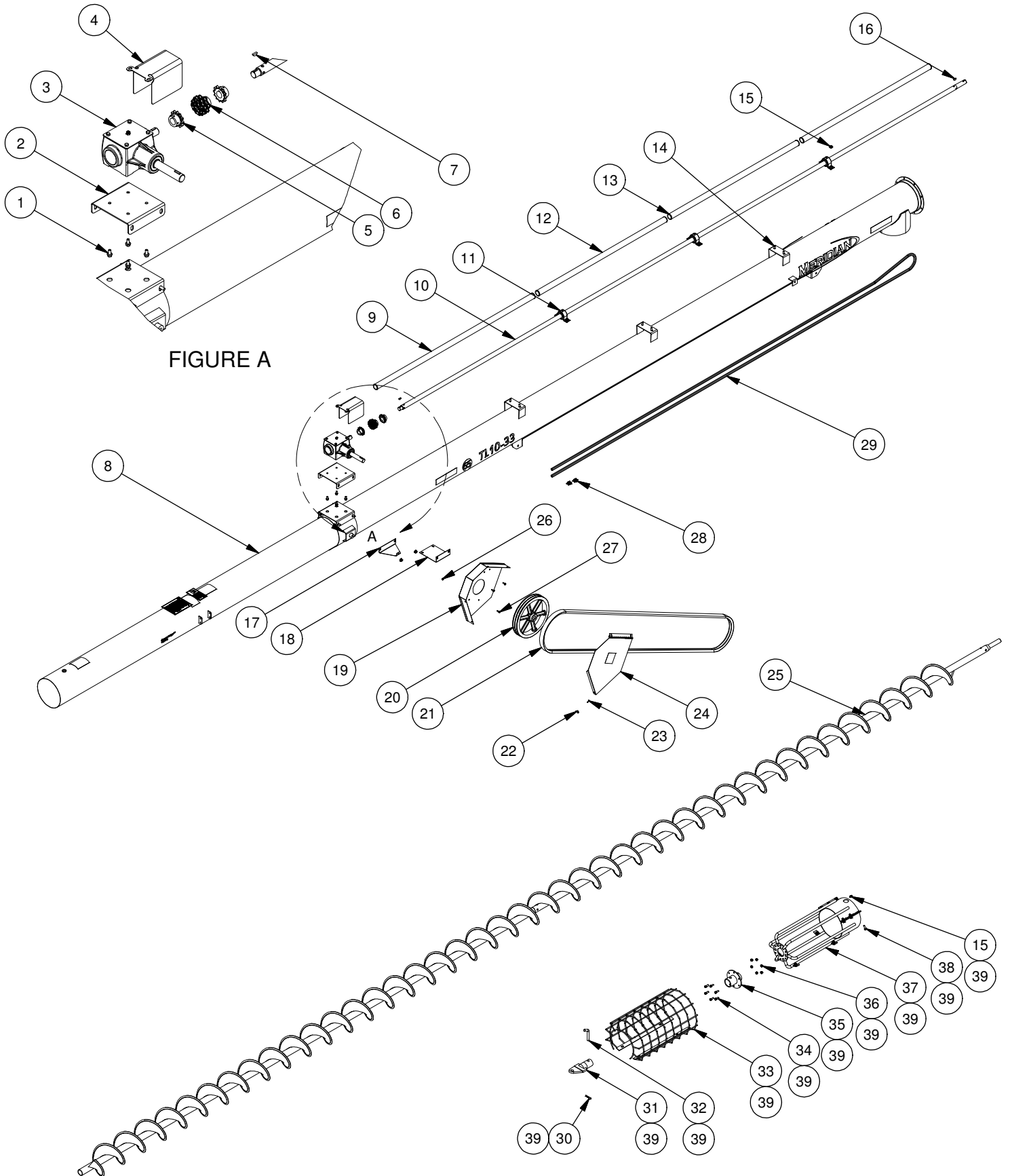

## PARTS

## TUBE ASSEMBLY - TL10-33

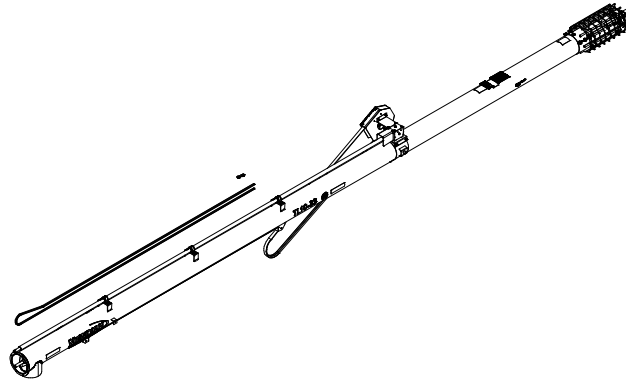

TL10-33			
REF #	PART #	QUANTITY	DESCRIPTION
1	13-0712-06012	4	Flange Bolt 3/8-16 UNC x 0.75
2	13000002843-00	1	Gear Box Plate
3	13000002858-00	1	Gear Box - TL10
4	13000001335-00	1	Guard Gear Box Shaft
5	13000001044-00	2	Sprocket - 50B12 - 1.125" Hardened
6	13000001045-00	1	Coupler Chain
7	13-0740-00807	1	Woodruff Key
8	13000002953-00	1	Tube
9	13000002466-01	1	D.S. GUARD (B. SECTION)
10	13000002375-00	1	Drive Shaft
11	13000001411-00	3	Split Pillow Block Bearing
12	13000001436-00	3	D.S. Guard ( B.Section) - HD8, TL10
13	13000001441-00	8	Drive Shaft Guard Bushing
14	13-0709-06016	10	Carriage Bolt 3/8-16 UNC - 1
15	13-0731-00006	20	Whiz-Lock Nut 3/8" - 14
16	11-0740-00808	1	Woodruff Key
17	13000002952-00	1	Lower Pulley Bracket
18	13000002951-00	1	Upper Pulley Bracket
19	13000003394-00	1	Guard Pulley
20	13000003393-00	1	Double Groove Sheave - 1 1/4" Bore 13.95" OD
21	13000001071-02	1	Belt - B-195 Banded Double
22	13-0732-00004	1	Wing Nut
23	13-0709-04012	3	Carriage Bolt 1/4 x 3/4-20
24	13000003341-00	1	Guard Cover Assembly
25	13000002954-00	1	Flight
26	13-0731-00004	5	Flange Nut 1/4-20 UNC
27	13-0712-04012	3	Flange Bolt 1/4-20 UNC x 0.75
28	13000001060-00	2	1/4" Galv. Cable Clamp
29	13000002442-00	1	Lift Cable
30	13-0739-02040	1	1/8" x 2 1/2" Hair Pin
31	13000001539-00	1	Hitch-Tube
32	13000001646-00	1	Bent Pull Pin 5/8" x 3"
33	13000001538-00	1	Guard
34	13-0702-06016	6	3/8-16 UNC - 1
35	13000005028-00	1	Fork End
36	13-0730-00006	6	Stover Nut 3/8-16
37	13000005027-00	1	Fork Intake
38	13-0712-06016	10	Flange Bolt 3/8-16 UNC x 1
39	13000001534-00	1	Intake Complete

# TUBE ASSEMBLY - TL10-39

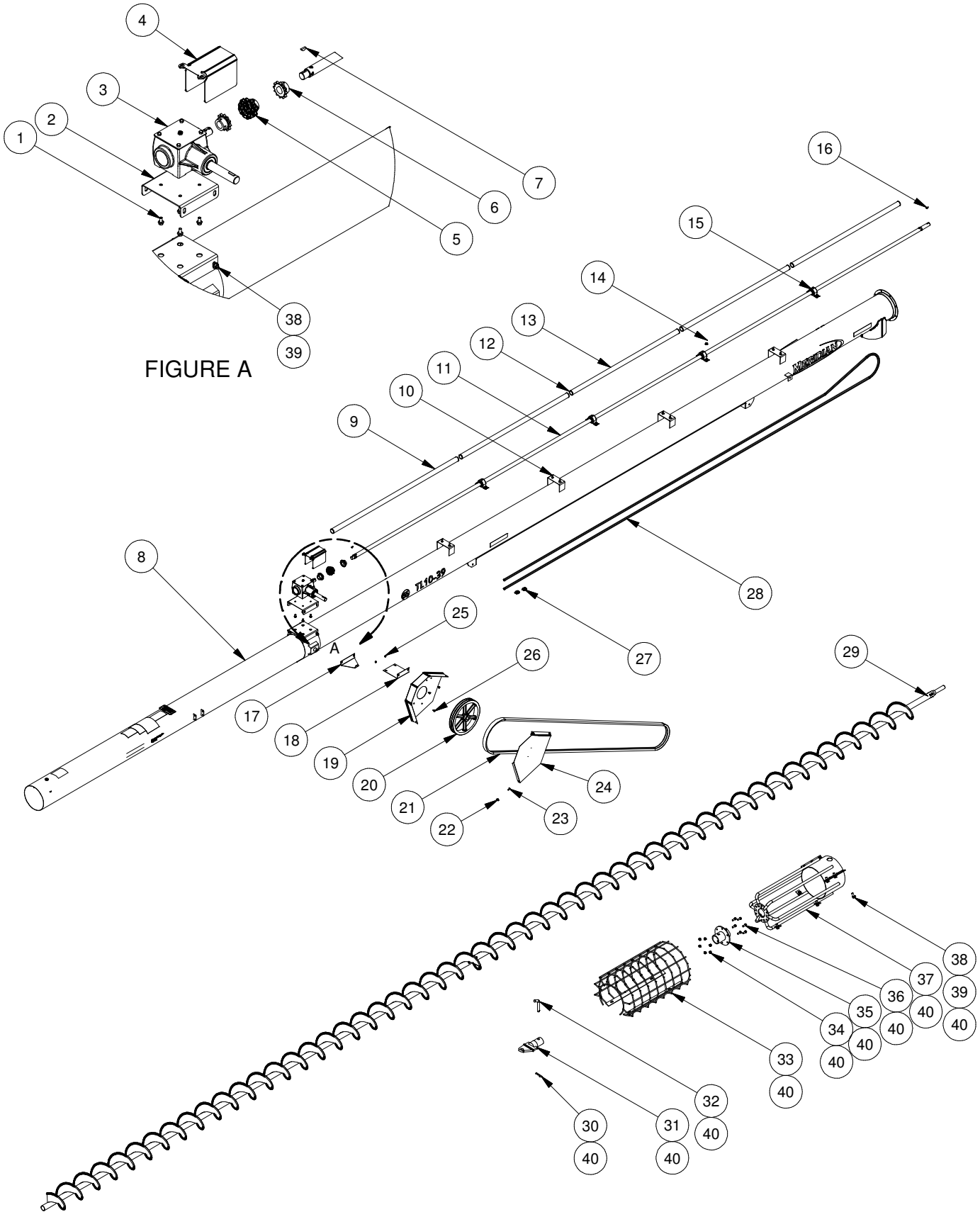



## PARTS

## TUBE ASSEMBLY - TL10-39

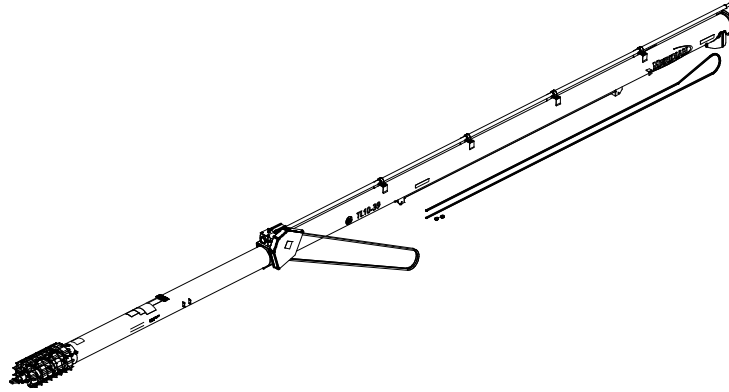

TL10-39			
REF #	PART #	QUANTITY	DESCRIPTION
1	13-0712-06012	4	Flange Bolt 3/8-16 UNC x 0.75
2	13000002843-00	1	Gear Box Plate
3	13000002858-00	1	Gear Box - TL10
4	13000001335-00	1	Guard Gear Box Shaft
5	13000001045-00	1	Coupler Chain
6	13000001044-00	2	Sprocket - 50B12 - 1.125" Hardened
7	13-0740-00807	1	Woodruff Key No 807
8	13000003661-00	1	Tube
9	13000002467-01	1	Guard Drive Shaft
10	13-0709-06016	8	Carriage Bolt 3/8-16 UNC - 1
11	13000001412-00	1	Drive Shaft
12	13000001441-00	10	Drive Shaft Guard Bushing
13	13000001436-00	4	D.S. Guard ( B.Section) - HD8, TL10
14	13-0731-00006	8	Flange Nut 3/8-16 UNC
15	13000001411-00	4	Split Pillow Block Bearing
16	11-0740-00808	1	Woodruff Key No 808
17	13000002952-00	1	Lower Pulley Bracket
18	13000002951-00	1	Upper Pulley Bracket
19	13000003394-00	1	Guard Pulley
20	13000003393-00	1	Double Groove Sheave - 1 1/4" Bore 13.95" OD
21	13000001072-02	1	Belt - B-225 Banded Double
22	13-0732-00004	1	Wing Nut 1/4"
23	13-0709-04012	3	Carriage Bolt 1/4" x 3/4"
24	13000003341-00	1	Guard Cover Assembly
25	13-0731-00004	5	Flange Nut 1/4-20 UNC
26	13-0712-04008	3	Flange Bolt 1/4-20 UNC x 0.5
27	13000001060-00	2	1/4" Galv. Cable Clamp
28	13000001423-00	1	Lift Cable
29	13000003662-00	1	Flight
30	13073902040	1	1/8" x 2 1/2" Hair Pin
31	13000001539-00	1	Hitch-Tube
32	13000001646-00	1	Bent Pull Pin 5/8" x 3"
33	13000001538-00	1	Guard
34	13-0730-00006	6	3/8-16 stover
35	13000005028-00	1	Fork End
36	13-0702-06016	6	3/8-16 UNC - 1
37	13000005027-00	1	Fork Intake
38	13071207016	14	7/16-14 UNC x 1 Flange Bolt
39	13-0731-00007	14	7/16-14 UNC Flange Nut
40	13000001534-00	1	Intake Complete

C10

13000004856-09-03

# MOTOR MOUNT ASSEMBLY

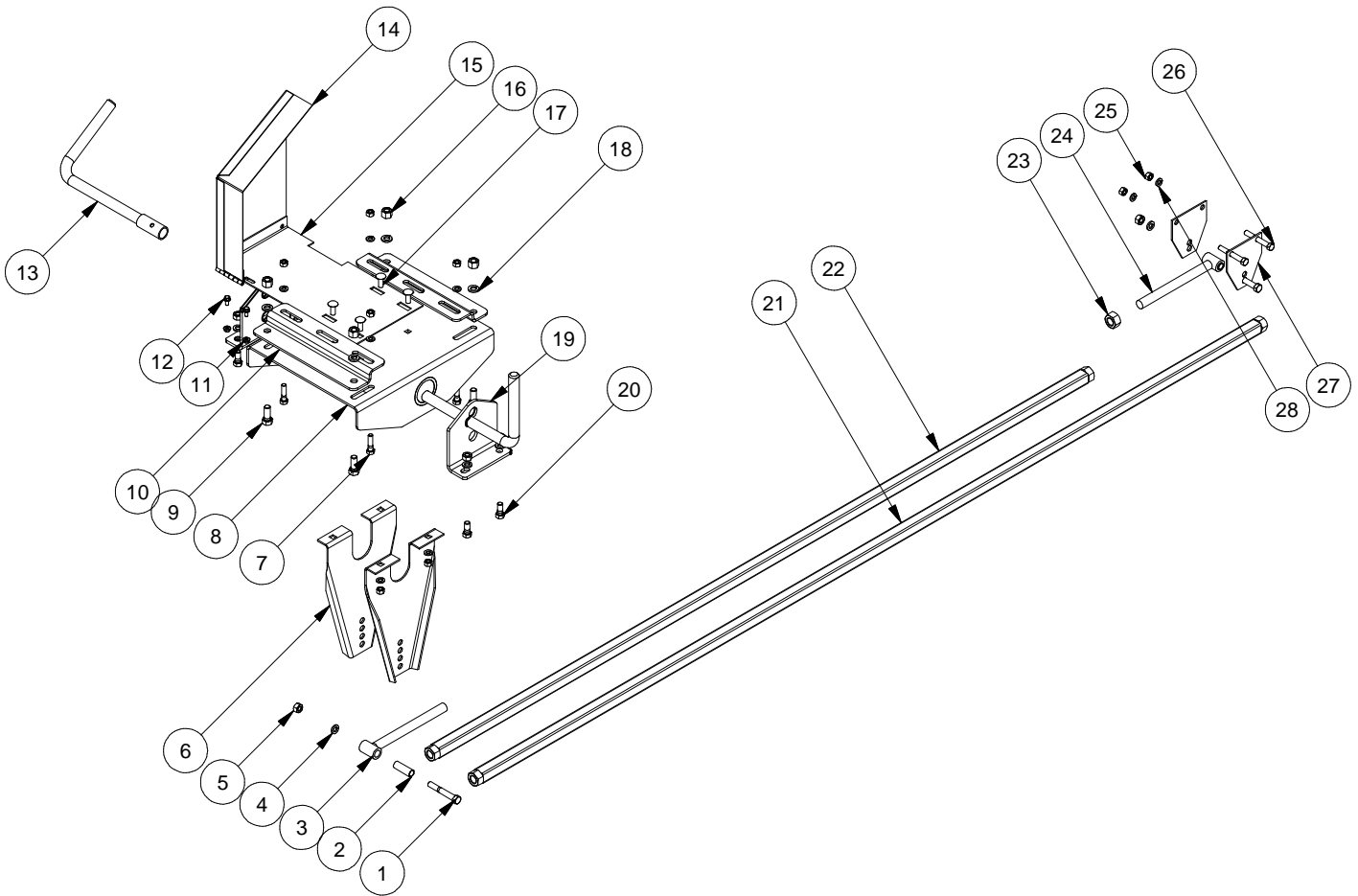

PARTS

# MOTOR MOUNT ASSEMBLY

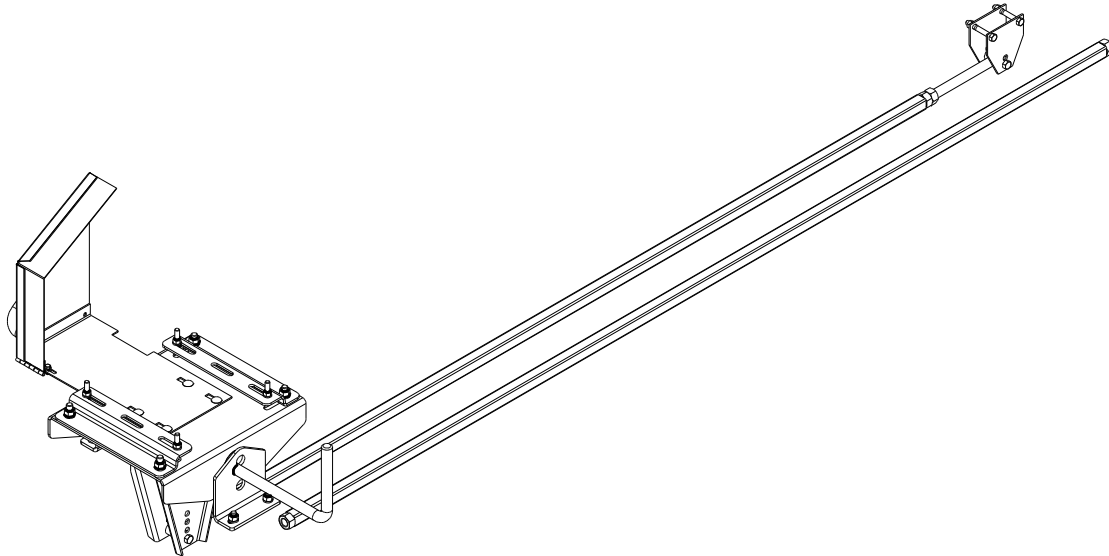

TL10			
REF #	PART #	QUANTITY	DESCRIPTION
1	13-0702-07048	2	Hex Cap Screw 7/16 x 3-14
2	13000001106-00	2	Leveling Bar Bushing
3	13000001107-00	1	Screw Leveling Bar Adjustable - LH
4	13-0734-00007	6	Spring Lock Washer 7/16
5	13-0725-00007	6	Hex Nut 7/16
6	13000001590-00	2	Lower Leveling Bar Bracket
7	13-0702-06024	4	Hex Cap Screw 3/8 x 1-1/2-16
8	13000001587-00	1	Motor Mount
9	13-0702-08020	4	Hex Cap Screw 1/2 x 1-1/4-13
10	13000002864-00	2	Motor Mount Bracket
11	13-0731-00004	2	Flange Lock Nut 1/4-20
12	13-0712-04008	2	Flange Lock Bolt 1/4 x 1/2-20
13	13000002964-00	1	Extension Handle (Optional)
14	13000001929-00	1	Guard Pulley Engine
15	13000002686-00	1	Pully Guard Base
16	13-0725-00008	4	Hex Nut 1/2-13
17	13-0709-06016	4	Carriage Bolt 3/8 x 1-16
18	13-0734-00008	4	Spring Lock Washer 1/2
19	13000001449-00	2	Pivot Bracket
20	13-0702-07016	4	Hex Cap Screw 7/16 x 1
21	13000001450-00	1	Leveling Bar - TL10-39
22	13000002439-00	1	Leveling Bar - TL10-33
23	13-0725-00012	1	Hex Nut 3/4 - 10
24	13000001114-00	1	Upper Leveling Bar
25	13-0725-00006	10	Hex Nut 3/8 - 16
26	13-0702-06044	2	Hex Cap Screw 3/8 x 2-3/4-16
27	13000001115-00	2	Upper Leveling Bar Bracket
28	13-0734-00006	10	Spring Lock Washer 3/8

## P.T.O. ATTACHMENT

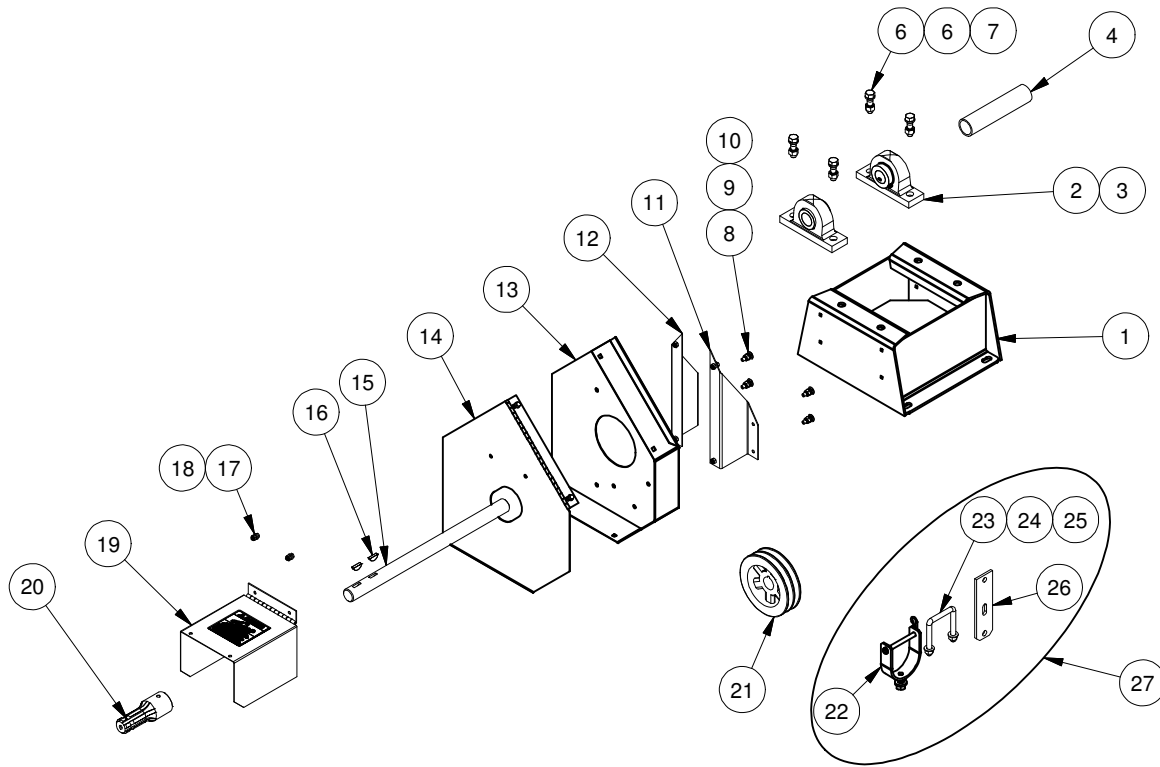

TL10			
REF #	PART #	QUANTITY	DESCRIPTION
1	13000001576-00	1	PTO Attachment Base
2	13000001213-00	2	Bearing Insert c/w Housing
3	13000001456-00	2	Ball Bearing Insert
4	13000002956-00	1	PTO Drive Shaft Guard
5	13-0734-00008	4	Helical Spring Lock Washer - 1/2"
6	13-0702-08028	4	Hex Bolt - 1/2-13 UNC - 1.75"
7	13-0725-00008	4	UNC Hex Nut - 1/2"
8	13-0709-05016	4	Carriage Bolt - 5/16-18 UNC - 1"
9	13-0734-00005	4	Helical Spring Lock Washer - 5/16"
10	13-0725-00005	4	UNC Hex Nut - 5/16"
11	13000001583-00	1	Pulley Guard Bracket - RH
12	13000001582-00	1	Pulley Guard Bracket - LH
13	13000003394-00	1	Guard Pulley
14	13000003342-00	1	PTO Guard Cover
15	13000002955-00	1	Drive Shaft
16	11-0740-00808	2	Woodruff Key - 1/4" x 1"
17	13-0712-04008	8	Flange Bolt - 1/4-20 UNC x 0.5"
18	13-0725-00004	8	1/4" UNC Hex Nut
19	13000001349-00	1	P.T.O. Guard
20	13000001459-00	1	P.T.O. Splined Stub
21	13000002504-00	1	Double Groove V-Pulley - 6"
22	13000002618-00	1	PTO Bracket Holder
23	13000003143-00	1	U-Bolt 7/16" x 2.5" x 4"
24	13-0734-00007	2	Lock Washer - Washer A - 7/16"
25	13-0725-00007	2	Hex Nut - 7/16" UNC
26	13000002619-00	1	Plate Base Bracket PTO
27	13000002870-00	1	PTO Bracket Kit

# PTO SHAFT

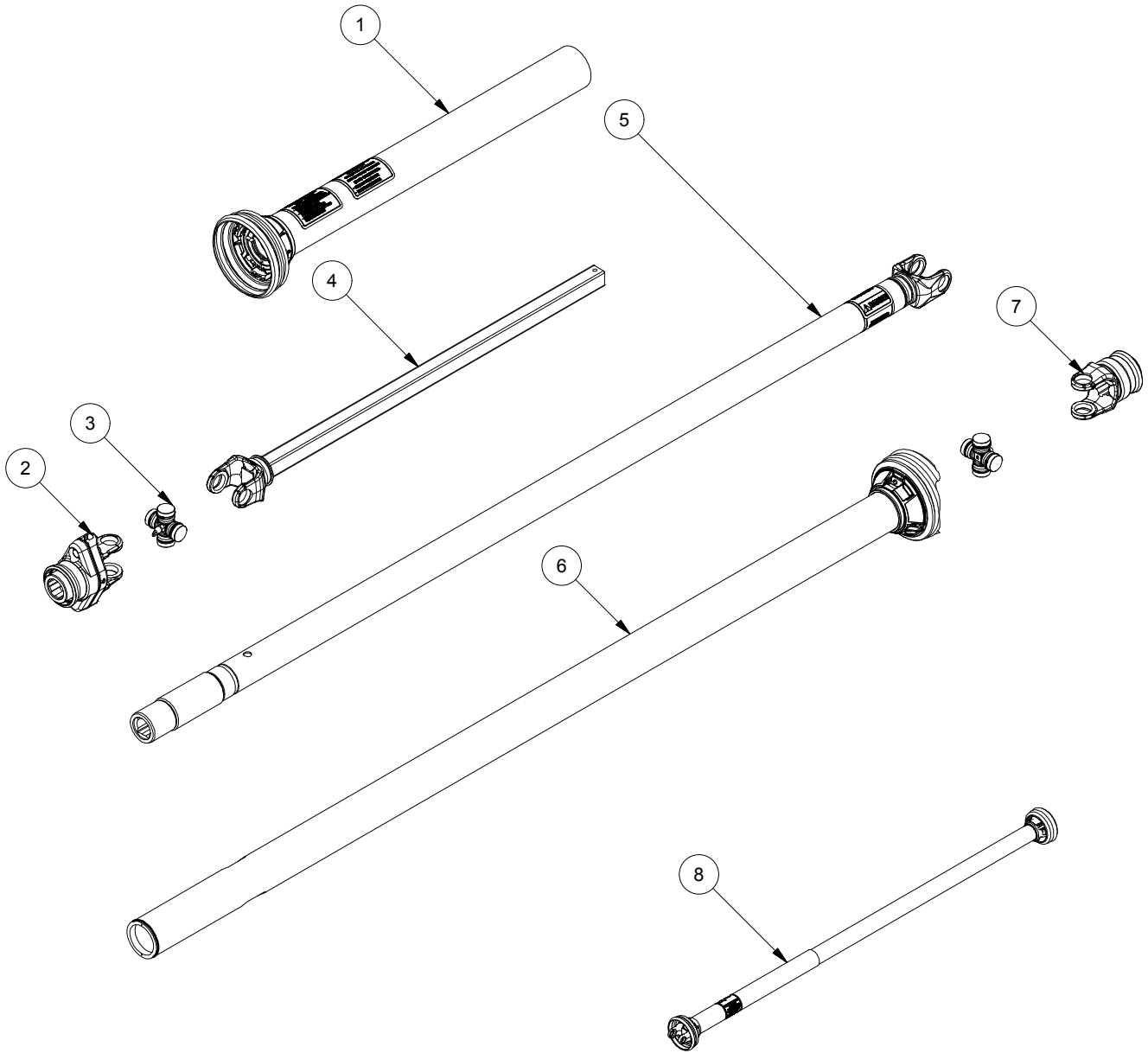

HD10			
REF #	PART #	QUANTITY	DESCRIPTION
1	13000001999-00	1	Outer PTO Shield
2	13000001987-00	1	PTO Ball Shear Assembly
3	13000001274-00	2	Cross & Bearing Kit
4	13000001996-00	1	Yoke & Male Shaft
5	13000002003-00	1	Yoke & Female Tube
6	13000002001-00	1	Inner PTO Shield
7	13000002004-00	1	Quick Disconnect Yoke
8	13000002036-00	-	Complete PTO Shaft

# FULTON K 2550 BRAKE WINCH

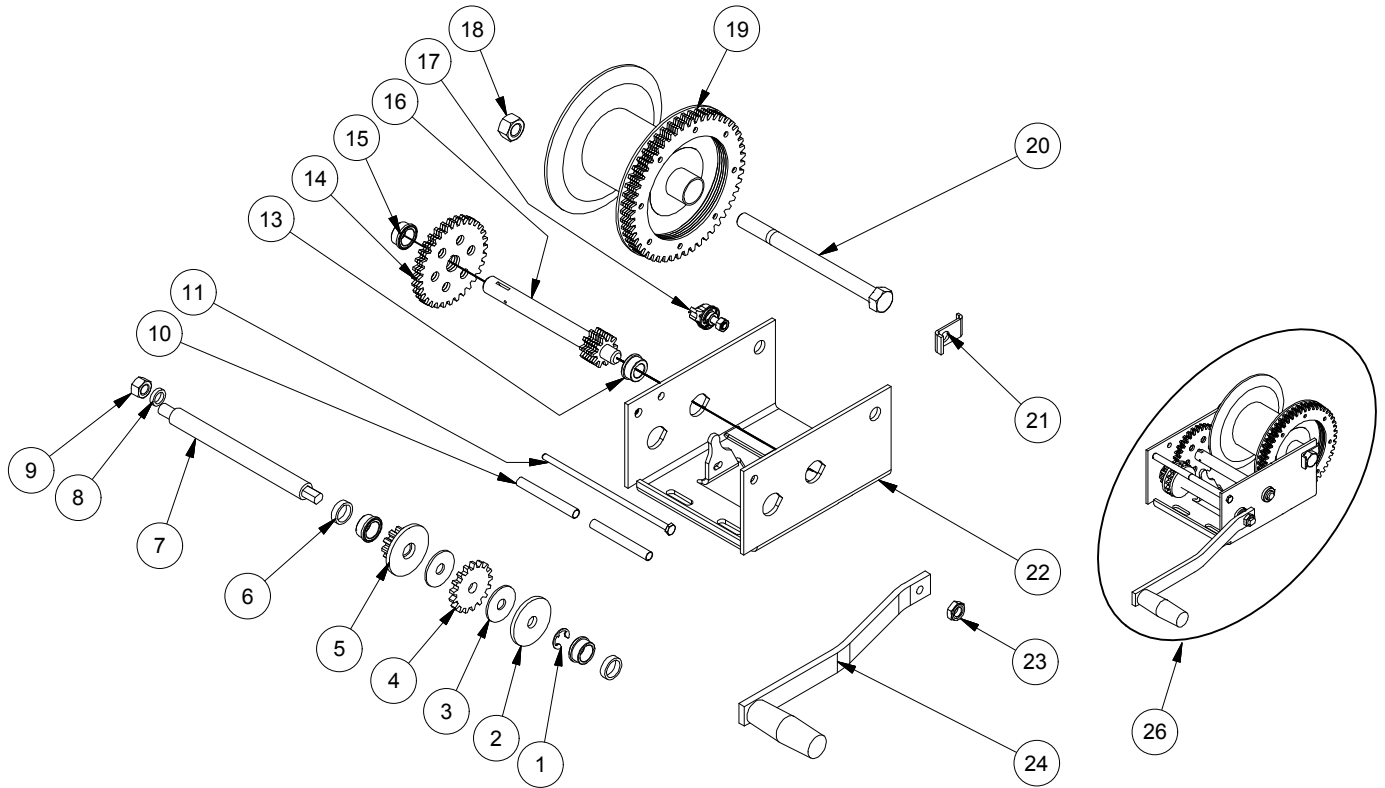

TL10			
REF #	PART #	QUANTITY	DESCRIPTION
1	-	1	E-Clip
2	13000003142-00	1	Shaft Brake Disc
3	13000001948-00	2	Friction Disc
4	13000001946-00	1	Ratchet Gear
5	13000001947-00	1	Pinion & Disc
6	-	2	Output Washer
7	13000002948-00	1	Input Shaft
8	-	1	Washer
9	-	1	Input Shaft Lock Nut
10	-	2	Frame Spacer (Not Available to Order)
11	-	1	Frame Spacer Bolt
13	13000001939-00	1	Bushing
14	13000001946-00	1	Ratchet Gear
15	13000001937-00	3	Bushing
16	13000001944-00	1	Output Shaft
17	13000001712-00	1	Pawl and Spring Kit
18	-	1	Drum Lock Nut
19	-	1	Drum Assembly C/W Spacer
20	-	1	Drum Bolt
21	-	1	Keeper (Not Available to Order)
22	-	1	Frame (Not Available to Order)
23	-	1	Handle Lock Nut
24	13000001711-00	1	Handle
25	13000001681-00	-	Complete Winch Assembly
26	13-0725-00004	1	Hex Nuts (Inch Series) Hex Nut

# GENERAL PARTS

PART NUMBER	DESCRIPTION
13000002949-00	Red Spray Paint
13000004846-00	Dark Grey Spray Paint
13000001920-00	10" Cupped Repair Flight w/ Shaft and Stub - 2"
13000001569-00	10" Regular Flight / Foot - 2" OD Shaft
13000001570-00	10" Cupped Flight / 2 Feet - 2" OD Shaft
13000001648-00	10" Flight Shaft Core / Foot - 2" OD
13000001530-02	10" Flight Shaft Stub - Joiner - 1 3/4" OD Shaft
13000002859-04	10" Flight Shaft Stub - 1 3/4" OD Shaft
13000003866-00	10" Helix - Cup / Foot - 2" OD Shaft
13000001648-00	10" Flight Shaft Core / Foot - 2" OD
13000001412-02	Flight Shaft Stub - Head - 1 1/4" OD
13000001412-03	Short Stub - Drive - 1 1/4" OD
13000001644-00	Drive Shaft / Foot - 1 3/8" OD
13000001571-00	10" Tubing / Foot
13000001526-13	10" Angle Flange
13000003702-00	Decal - TL10-33
13000003703-00	Decal - TL10-39
13000003685-00	Decal - Meridian
13000001653-00	Decal - Caution (Large)
13000001654-00	Decal - Warning
13000001655-00	Decal - Danger - Upending Hazard
13000001656-00	Decal - Danger - Electrocuting Hazard
13000001657-00	Decal - Danger - Rotating Flighting
13000001658-00	Decal - Warning - Mover Part Hazard
13000001659-00	Decal - Caution (Small)
13000001660-00	Decal - Rotating Drive Line
13000004944-00	Decal - Grease Zerk Location
13000002901-00	Reflector Yellow
13000002900-00	Reflector Red
13000004971-00	Kit - Bolt On Repair Band 10in

# INDEX

Part #	Page	Ref #	Part #	Page	Ref #	Part #	Page	Ref #
11-0740-00808	C2	8	13000001094-00	C2	11	13000001534-00	C7	36
11-0740-00808	C1	11	13000001095-00	C2	14	13000001535-00	C7	34
11-0740-00808	C9	16	13000001106-00	C11	2	13000001536-00	C7	33
11-0740-00808	C7	16	13000001107-00	C11	3	13000001538-00	C9	32
11-0740-00808	C13	16	13000001114-00	C11	24	13000001538-00	C7	32
13000001004-00	C5	23	13000001115-00	C11	27	13000001539-00	C9	30
13000001004-00	C6	21	13000001204-00	C2	15	13000001539-00	C7	30
13000001005-00	C5	19	13000001207-00	C2	17	13000001569-00	C16	N/A
13000001005-00	C6	25	13000001208-00	C2	16	13000001570-00	C16	N/A
13000001006-00	C5	24	13000001213-00	C13	2	13000001571-00	C16	N/A
13000001006-00	C6	26	13000001223-00	C5	14	13000001576-00	C13	1
13000001007-00	C5	25	13000001223-00	C6	15	13000001582-00	C13	12
13000001007-00	C6	27	13000001274-00	C14	3	13000001583-00	C13	11
13000001008-00	C5	26	13000001335-00	C9	4	13000001587-00	C11	8
13000001008-00	C6	19	13000001335-00	C7	4	13000001590-00	C11	6
13000001009-00	C5	18	13000001349-00	C13	19	13000001644-00	C16	N/A
13000001009-00	C6	20	13000001363-00	C5	3	13000001646-00	C9	31
13000001010-00	C5	17	13000001364-00	C5	9	13000001646-00	C7	31
13000001010-00	C6	18	13000001364-00	C6	8	13000001648-00	C16	N/A
13000001011-00	C5	27	13000001365-00	C5	6	13000001648-00	C16	N/A
13000001011-00	C6	16	13000001365-00	C6	7	13000001653-00	C16	N/A
13000001012-00	C5	15	13000001366-00	C5	10	13000001654-00	C16	N/A
13000001012-00	C6	14	13000001366-00	C6	9	13000001655-00	C16	N/A
13000001016-00	C5	7	13000001381-00	C4	2	13000001656-00	C16	N/A
13000001016-00	C6	6	13000001387-00	C5	20	13000001657-00	C16	N/A
13000001017-00	C4	24	13000001387-00	C6	22	13000001658-00	C16	N/A
13000001017-00	C5	8	13000001411-00	C9	15	13000001659-00	C16	N/A
13000001017-00	C6	11	13000001411-00	C7	11	13000001660-00	C16	N/A
13000001044-00	C9	6	13000001412-00	C9	11	13000001668-00	C1	5
13000001044-00	C7	5	13000001412-02	C16	N/A	13000001670-00	C5	22
13000001045-00	C9	5	13000001412-03	C16	N/A	13000001670-00	C6	24
13000001045-00	C7	6	13000001423-00	C9	28	13000001681-00	C3	5
13000001060-00	C9	27	13000001436-00	C9	13	13000001681-00	C4	6
13000001060-00	C7	28	13000001436-00	C7	12	13000001681-00	C15	25
13000001071-02	C7	21	13000001441-00	C9	12	13000001711-00	C15	24
13000001072-00	C9	21	13000001441-00	C7	13	13000001712-00	C15	17
13000001083-00	C2	6	13000001449-00	C11	19	13000001920-00	C16	N/A
13000001084-00	C2	5	13000001450-00	C11	21	13000001923-00	C3	15
13000001085-00	C2	4	13000001456-00	C1	2	13000001923-00	C4	8
13000001086-00	C2	3	13000001456-00	C13	3	13000001924-00	C3	7
13000001088-00	C2	10	13000001459-00	C13	20	13000001924-00	C4	10
13000001089-00	C2	2	13000001494-00	C2	22	13000001926-00	C3	10
13000001090-00	C2	18	13000001524-00	C4	1	13000001926-00	C4	18
13000001091-00	C2	13	13000001526-13	C16	N/A	13000001929-00	C11	14
13000001092-00	C2	1	13000001530-02	C16	N/A	13000001937-00	C15	15
13000001093-00	C2	9	13000001534-00	C9	39	13000001939-00	C15	13



## INDEX

Part #	Page	Ref #	Part #	Page	Ref #	Part #	Page	Ref #
13000001944-00	C15	16	13000002948-00	C15	7	13-0702-06044	C11	26
13000001946-00	C15	4	13000002949-00	C16	N/A	13-0702-06056	C3	2
13000001946-00	C15	14	13000002951-00	C9	18	13-0702-06056	C3	20
13000001947-00	C15	5	13000002951-00	C7	18	13-0702-06056	C4	21
13000001948-00	C15	3	13000002952-00	C9	17	13-0702-06144	C3	6
13000001987-00	C14	2	13000002952-00	C7	17	13-0702-06144	C4	14
13000001996-00	C14	4	13000002953-00	C7	8	13-0702-07016	C11	20
13000001999-00	C14	1	13000002954-00	C7	25	13-0702-07020	C4	26
13000002001-00	C14	6	13000002955-00	C13	15	13-0702-07048	C11	1
13000002003-00	C14	5	13000002956-00	C13	4	13-0702-07056	C3	18
13000002004-00	C14	7	13000002957-00	C2	20	13-0702-07056	C4	7
13000002036-00	C14	8	13000002959-00	C2	12	13-0702-07064	C3	9
13000002340-00	C1	10	13000002964-00	C11	13	13-0702-07064	C4	19
13000002354-00	C3	14	13000003117-00	C3	23	13-0702-08020	C11	9
13000002355-00	C4	9	13000003117-00	C4	27	13-0702-08024	C1	8
13000002365-00	C5	1	13000003142-00	C15	2	13-0702-08028	C13	6
13000002366-00	C6	1	13000003143-00	C13	23	13-0702-08064	C5	2
13000002372-00	C3	8	13000003341-00	C9	24	13-0702-08064	C6	3
13000002372-00	C4	20	13000003341-00	C7	24	13-0702-10064	C5	11
13000002375-00	C7	10	13000003342-00	C13	14	13-0702-10064	C6	10
13000002439-00	C11	22	13000003393-00	C9	20	13-0707-04012	C1	12
13000002442-00	C7	29	13000003393-00	C7	20	13-0709-04012	C9	23
13000002466-00	C7	9	13000003394-00	C9	19	13-0709-04012	C7	23
13000002467-00	C9	9	13000003394-00	C7	19	13-0709-05016	C13	8
13000002504-00	C13	21	13000003394-00	C13	13	13-0709-06016	C11	17
13000002511-00	C1	3	13000003518-00	C3	19	13-0709-06016	C9	10
13000002618-00	C13	22	13000003518-00	C4	15	13-0709-06016	C7	14
13000002619-00	C13	26	13000003661-00	C9	8	13-0712-04008	C11	12
13000002686-00	C11	15	13000003662-00	C9	29	13-0712-04008	C9	26
13000002719-00	C1	6	13000003685-00	C16	N/A	13-0712-04008	C13	17
13000002838-00	C1	1	13000003702-00	C16	N/A	13-0712-04012	C7	27
13000002840-00	C3	13	13000003703-00	C16	N/A	13-0712-06012	C9	1
13000002840-00	C4	13	13000003866-00	C16	N/A	13-0712-06012	C7	1
13000002841-00	C1	7	13000004637-00	C2	19	13-0712-06016	C4	5
13000002843-00	C9	2	13000004846-00	C16	N/A	13-0712-06016	C7	35
13000002843-00	C7	2	13000004944-00	C16	N/A	13-0712-07016	C9	37
13000002858-00	C2	23	13000004971-00	C16	N/A	13-0725-00004	C15	26
13000002858-00	C9	3	13000005026-00	C6	2	13-0725-00004	C13	18
13000002858-00	C7	3	13000005027-00	C9	36	13-0725-00005	C13	10
13000002859-04	C16	N/A	13000005028-00	C9	34	13-0725-00006	C11	25
13000002864-00	C11	10	13-0702-04016	C3	1	13-0725-00006	C4	3
13000002870-00	C13	27	13-0702-05012	C2	7	13-0725-00007	C11	5
13000002892-00	C3	21	13-0702-06016	C3	4	13-0725-00007	C3	12
13000002892-00	C4	22	13-0702-06016	C9	35	13-0725-00007	C4	12
13000002900-00	C16	N/A	13-0702-06024	C11	7	13-0725-00007	C13	25
13000002901-00	C16	N/A	13-0702-06040	C4	25	13-0725-00008	C11	16

**INDEX**

13-0725-00008	C1	4	13-0731-00007	C9	38	13-0734-00008	C13	5
13-0725-00008	C5	12	13-0732-00004	C9	22	13-0734-00010	C5	5
13-0725-00008	C6	13	13-0732-00004	C7	22	13-0734-00010	C6	5
13-0725-00008	C13	7	13-0734-00005	C13	9	13-0734-00012	C3	11
13-0725-00010	C5	4	13-0734-00006	C11	28	13-0734-00012	C4	11
13-0725-00010	C6	4	13-0734-00006	C3	22	13-0735-00012	C3	17
13-0725-00012	C11	23	13-0734-00006	C4	23	13-0735-00012	C4	17
13-0730-00006	C9	33	13-0734-00007	C11	4	13-0737-04032	C5	21
13-0731-00004	C11	11	13-0734-00007	C3	16	13-0737-04032	C6	23
13-0731-00004	C9	25	13-0734-00007	C4	16	13-0737-05040	C5	16
13-0731-00004	C7	26	13-0734-00007	C13	24	13-0737-05040	C6	17
13-0731-00006	C3	3	13-0734-00008	C11	18	13-0740-00807	C9	7
13-0731-00006	C4	4	13-0734-00008	C1	9	13-0740-00807	C7	7
13-0731-00006	C9	14	13-0734-00008	C5	13	13-0740-00809	C2	21
13-0731-00006	C7	15	13-0734-00008	C6	12			

# Limited Warranty Statement

1. Meridian Manufacturing Inc warrants each new Meridian Manufacturing Inc product (the "Goods") to be free from defects in material and workmanship under normal use and service for a period of two (2) years or ninety (90) days in the case of commercial use, from the shipment date from the Meridian dealer (FCA).
2. Meridian warrants replacement parts and components either manufactured or sold by, will be free from defects in materials or workmanship under normal use and service for thirty (30) days from the shipment date from the Meridian dealer (FCA), or the remainder of the original warranty period on the Goods, whichever is longer.
3. This warranty does not apply to:
  - a) to any merchandise or components thereof, which in the sole and unfettered opinion of Meridian, have been subject to misuse, unauthorized modifications, alteration, accident, negligence, product abuse or lack of required maintenance.
  - b) if repairs have been made with parts or by persons other than those parts or persons approved by Meridian.
  - c) to parts and accessories not manufactured by Meridian including, but not limited to, engines, batteries, tires, belts, PTO shafts or other trade accessories. Such parts shall be covered by the warranty given by the actual manufacturer, if any.
  - d) to failure of parts; or failure of parts to perform due to wear under normal or excessive service conditions; or to failure due to use by the Purchaser for purposes other than originally intended at time of manufacture, including without limitation using the Goods for mixing fertilizer, etc.; or used in excess of the built specifications.
  - e) to Goods used in areas exposed to corrosive or aggressive conditions including, but not limited to, salt water from either inside or outside the Goods.
  - f) to failures or defects arising out of damage during shipment or during storage.
  - g) to materials replaced or repaired under this warranty, except to the extent of the remainder of the applicable warranty.
4. The obligation of Meridian under this warranty shall not arise unless Meridian is notified and this warranty is presented together with a written statement specifying the claim or defect within thirty (30) days after the failure is first detected or made known to the Purchaser and within: (i) two (2) years, or ninety (90) days in the case of commercial use; or (ii) thirty (30) days in the case of replacement parts and components manufactured by Meridian; from the shipment date from the Meridian dealer (FCA). Meridian in its sole and unfettered discretion shall determine if the claim is valid and whether correction of the defect or failure shall be made by repair or replacement of the materials.
5. Title to any replaced materials Meridian wishes to have pass to it, shall pass to Meridian.
6. The obligation of Meridian hereunder extends only to the original Purchaser or Buyer to whom the Goods were initially sold. This warranty shall not be subject to any assignment or transfer without the written consent of Meridian.
7. The purchaser acknowledges that it has made its own independent decision to approve the use of the Goods and also the specific fabrication and construction procedures utilized to complete the Goods, and has satisfied itself as to the suitability of these products for its use.

8. This warranty is subject to the following limitations, provisions and conditions:
- a) Meridian shall have no liability hereunder for any claims, including field re-work.
  - b) Meridian shall not be liable for any incidental loss or damage, however caused, including, without limitation, normal wear and tear.
  - c) Meridian makes no express or implied warranties of any nature whatsoever except for such express warranties as set out herein. The warranty provided herein is in lieu of and excludes all other warranties, guarantees or conditions pertaining to the Goods, written or oral, statutory, express or implied, (except the warranty as to title) including any warranty as to the merchantability or fitness for any particular purpose. Meridian expressly disclaims all other representations, conditions or warranties, expressed or implied, statutory or otherwise and any representations, warranties or conditions that may arise from a course of dealing or usage of trade. The warranty provided herein shall constitute Meridian's sole obligation and liability and the Purchaser's sole remedy for breach of warranty. No other warranty has been made by any employee, agent, or representative of Meridian and any statements contained in any other printed material of Meridian is expressly excluded herefrom. Meridian shall not be responsible for any warranty offered by the Purchaser to its customers with respect to the Goods and the Purchaser shall indemnify Meridian with respect to same if any of those customers makes a claim against Meridian relating to any such warranty.
  - d) Subject to Meridian's obligations contained in paragraphs 1 and 2 herein, none of Meridian, its officers, directors, servants or agents shall be liable, or responsible for any loss or damage (including strict liability and liability for loss or damage due to items which the manufacturing processes are designed to identify) whether such loss or damage is caused by negligence in any manner whatsoever (including gross negligence, error, misrepresentation, misstatement, imprudence, lack of skill or lack of judgement).
9. The sole financial obligation of Meridian under this warranty shall be limited to the repair or replacement of the Goods as originally supplied and in no event shall they exceed the original cost of the Goods supplied.
10. Meridian shall not have any obligation under any warranty herein until all accounts have been paid in full by the Purchaser.
11. The construction and interpretation of this Warranty shall be governed by the laws of the Province of Saskatchewan.

## **Warranty Claim Procedure**

- 1. Purchaser must register the Goods with Meridian.
- 2. Purchaser must contact the dealer where the unit was purchased from upon discovery of any defects.
- 3. A completed warranty claim form must be submitted by the dealer to Meridian's warranty representative for review and any subsequent course of action.
- 4. Warranty repair work will only be performed by Meridian or an approved representative of Meridian. No warranty work completed prior to approval by Meridian will be honored. Failure to follow procedure may affect any or all of this warranty.
- 5. Claims will be adjudicated at the sole discretion of Meridian and in accordance with the terms and conditions of the limited warranty.

# MERIDIAN MANUFACTURING INC.

With over 65 years of experience,  
Meridian is your storage and handling expert.



[www.meridianmfg.com](http://www.meridianmfg.com)

**Cambridge Office**

605 Sheldon Dr.  
Cambridge, On. N1T 2K1  
PH: 519.620.6004  
TF: 855.346.3712  
FX: 519.620.6041

**Camrose Office**

4232 - 38 St.  
Camrose, AB T4V 4B2  
PH: 780.672.4516  
TF: 800.830.2467  
FX: 780.672.4759

**Lethbridge Office**

3125 - 24 Ave. N.  
Lethbridge, AB T1H 5G2  
PH: 403.320.7070  
TF: 800.661.1436  
FX: 403.320.7579

**Regina Office**

PO Box 1996  
Regina, SK S4P 3E1  
PH: 306.545.4044  
TF: 800.667.5904  
FX: 306.545.4216

**Storm Lake Office**

2902 Expansion Blvd.  
Storm Lake, IA 50588  
PH: 712.732.1780  
TF: 800.437.2334  
FX: 712.732.1028

**Winkler Office**

Box 760, 275 Hespler Ave.  
Winkler, MB R6W 4A8  
PH: 204.325.7883  
TF: 800.665.7259  
FX: 204.325.5556