



OPERATOR'S MANUAL



FOR FUEL TRAILERS

CERTIFIED FOR CANADIAN MARKET

www.MeridianMFG.com



Fuel Express Trailers Operator's Manual

**Please read these instructions
carefully and completely
before operating.**

NOTICE TO THE USER MERIDIAN FUEL TRAILER – CANADIAN MARKET

Date: June 5, 2014

The Meridian Fuel Trailer contains an Intermediate Bulk Container (IBC) – in essence the tank assembly portion of the fuel trailer, that is registered to Transport Canada (TC). The IBC is a steel type 31A Mobile IBC for liquids and has been designed, tested and registered in compliance with TC requirements. The fuel trailer can legally be used in Canada to transport flammable and combustible liquids. This includes Class 3 fluids, as defined by the Canadian Transportation Of Dangerous Goods regulations, including Packing Groups II and III. Effectively, this allows the user to transport diesel fuel, gasoline, and all other liquids defined by Class 3, Packing Groups II and III.

In compliance with the testing requirements specified by Transport Canada, the IBC has been tested to specification CAN/CGSB-43.146-2002 which includes leak, hydraulic pressure, drop, vibration and roll-over testing. Testing was to the Packing Group II standard.

Filling the IBC is through the camlock fill cap or vented fill cap located within the protected manway on the top of the tank/IBC. Both the vented cap and camlock cap use a standard thread orientation – rotate counterclockwise to open and clockwise to close.

Published by:

Meridian Manufacturing, Inc.
2902 Expansion Blvd.
Storm Lake, Iowa, 50588
USA

www.meridianmfg.com

October, 2014

Printed in USA

©2014 Meridian Manufacturing, Inc.
Information subject to change without written notice.

PRODUCT WARRANTY REGISTRATION FORM



www.meridianmfg.com

WARRANTY REGISTRATION

This form must be filled out by the dealer and signed by both the dealer and the customer at the time of delivery. Please mail or fax the completed form for validation of the equipment registration.

Customer's Name _____

Address _____

City, State, Postal Code _____, _____, _____

Phone Number (_____) _____ - _____

PRODUCT INFORMATION

Fuel Trailer Model # _____

Serial Number # _____

I have thoroughly instructed the buyer on the above-described equipment, including review of the Operator's Manual content, equipment care, adjustments, operational use, safety procedures, and applicable warranty policy.

Dealer/Company Name _____

City, State, Postal Code _____, _____, _____

Dealer's Signature _____ Date ____/____/____

The above equipment and Operator's Manual have been received by me and I have been thoroughly instructed as to care, adjustments, safe operation, and applicable warranty policy.

Owner's Signature _____ Date ____/____/____

2902 Expansion Blvd. Storm Lake, Iowa 50588 Phone: 800-437-2334 Fax: 712-732-1028 Email: iowa_warranty@meridianmfg.com

Cut Here to Remove Page

PRODUCT WARRANTY

REGISTRATION FORM



www.meridianmfg.com

DEALER INSPECTION REPORT

- ___ Review safety and operating instructions with owner
- ___ Verify receipt of all options ordered
- ___ Verify that tow vehicle is large enough to safely tow the trailer
- ___ Inspect customer's hitch for 2-5/16" ball
- ___ Make sure hitch-to-tongue bolts are tight
- ___ Make sure safety chains are properly attached and are in good working condition
- ___ Wiring harness plug must be in working condition and fit into tow vehicle's receptacle
- ___ Make sure license plate light is operating and visible
- ___ Make sure turn signal lights are operating and visible
- ___ Make sure brake lights are operating and visible
- ___ Reflector tape must be clean and visible
- ___ Make sure breakaway cable and pin are supplied with trailer
- ___ Check breakaway battery
- ___ Check air pressure in tires
- ___ Wheel nuts/bolts must be tightened to proper torque on all wheels
- ___ Make sure owner is instructed to check wheel bolt/nut torque at 5, 10, 25, and 50 miles; then check annually
- ___ Make sure electric brakes are working
- ___ Make sure all guards/shields are installed correctly
- ___ Make sure all safety signs are installed and legible
- ___ Make sure all four fuel placards are installed once the tank has been filled
- ___ Make sure 12 volt battery is fully charged and in good working order
- ___ If equipped, check gasoline engine fuel level
- ___ If equipped, check gasoline engine oil level
- ___ If equipped, start gasoline engine



www.meridianmfg.com

2902 Expansion Blvd.
Storm Lake, IA 50588
Phone: 712-732-1780
Fax: 712-732-1028

CERTIFICATE OF ORIGIN

LICENSING INFORMATION

Date: ____/____/____

DEALER:

Business

Contact

Address

City, State, Zip

SOLD TO:

Business

Contact

Address

City, State, Zip

FUEL TRAILER MODEL # _____

FUEL TRAILER WEIGHT _____

- Fuel Trailer Bone White
- Fuel Trailer Red
- Fuel Trailer Grey

Cut Here to Remove Page

IMPORTANT INFORMATION

SERIAL NUMBER LOCATION

Please provide the serial number of your Meridian Fuel Trailer, the engine, fuel pump, and the IBC when ordering parts or requesting service or other information.

The serial number plates are located where indicated. Please record the numbers in the space provided below for easy reference.

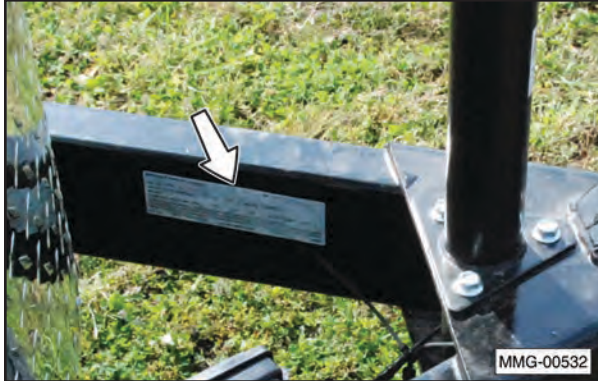

Fuel Trailer

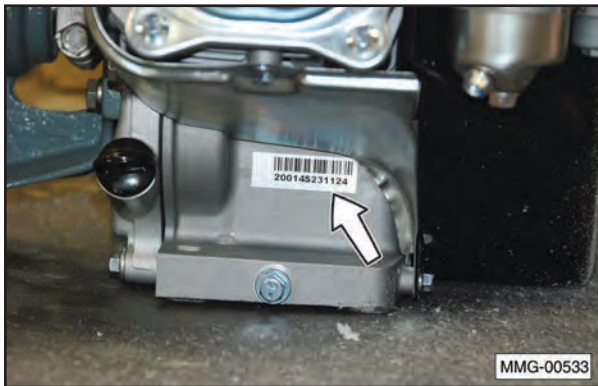

Engine



IBC (Fuel Tank)



Fuel Pump (Gasoline Engine)

Model Number: _____

Trailer Serial Number: _____

IBC Serial Number: _____

Gasoline Engine Serial Number: _____

Fuel Pump Serial Number: _____

PATENT INFORMATION



Meridian continuously enhances its product offering through product improvements and new product innovations. Marketplace feedback, technological innovation, new materials and manufacturing methods, and a philosophy of continuous improvement constantly challenge the company to develop new and better ways of addressing market needs. Meridian is committed to innovation and reinvestment and as a result, the company maintains a portfolio of patents and intellectual property. For more information on our patents please see our website: www.meridianmfg.com/patents

1. CONTENTS

2. INTRODUCTION	2-1
2.1 Congratulations	2-1
2.2 Operator Orientation	2-1
2.3 Owner/Operator	2-1
2.4 Disposal of Equipment at End of Useful Life	2-1
2.5 Continuous Improvement Process	2-1
2.6 Before Starting Gas Engine	2-2
2.6.1 Door Keys	2-2
2.6.2 Check Oil Level	2-2
2.6.3 Prime Gasoline Engine Fuel Pump (Diesel Only)	2-2
2.6.4 Prime DEF Pump	2-2
3. SAFETY	3-1
3.1 Additional Safety Words	3-2
3.2 Safety Training	3-2
3.3 Safety Icon Nomenclature	3-3
3.3.1 Personal Protection/Important Information	3-3
3.3.2 Prohibited Actions	3-3
3.3.3 Hazard Avoidance	3-3
3.4 General Safety	3-4
3.5 Safety Signs	3-5
3.6 Preparation	3-5
3.7 Transport Safety	3-5
3.8 Storage Safety	3-5
3.9 Operating Safety	3-5
3.10 Maintenance Safety	3-5
3.11 Diesel Fuel Safety	3-5
3.11.1 Inhalation Hazard	3-5
3.11.2 Fire and Explosion Hazards	3-5
3.11.3 Static Electricity Hazard	3-5
3.11.4 Ingestion	3-6
3.11.5 Eye Protection	3-6
3.11.6 Skin Protection	3-6
3.11.7 Storage Precautions	3-6
3.11.8 U.S. Federal, State, and Local Regulatory Information	3-6
3.11.9 Canada Regulatory Information	3-7
3.11.10 Spill Reporting	3-7
3.12 Battery Safety	3-7
3.12.1 General Hazards	3-7
3.12.2 Ventilation Hazard	3-7
3.12.3 Shock Hazards	3-7
3.12.4 Explosion Hazards	3-8
3.13 Sign-Off Form	3-9
4. SAFETY SIGNS	4-1
4.1 General Information	4-1
4.2 How to Install Safety Signs	4-1
4.3 Safety Sign Locations	4-1
4.4 Installing Fuel Placards	4-3
4.4.1 Emergency Response	4-4
5. SPECIFICATIONS	5-1
5.1 Overall Dimensions	5-1
5.2 Specifications	5-2
5.3 Bolt Specifications	5-3
5.3.1 Bolt Torque Values	5-3
5.3.2 Grade Markings Chart	5-3

6. EQUIPMENT COMPONENTS AND CONTROLS	6-1
6.1 Component Nomenclature and Location	6-1
6.2 Gasoline Engine and Controls.	6-2
7. PRE-OPERATING INSTRUCTIONS	7-1
7.1 Equipment Break-In Period	7-1
7.1.1 Inspections for 1/2, 5, and 10 Hours	7-1
7.2 Daily Pre-Operation Checklist.	7-2
8. TOWING	8-1
8.1 Transport Safety.	8-1
8.2 Connecting the Trailer.	8-2
9. OPERATION	9-1
9.1 Operating Safety	9-1
9.2 Fire Extinguisher	9-2
9.3 Pre-Operation Checks.	9-2
9.4 DEF and Diesel Fuel Tanks	9-3
9.4.1 Filling the Fuel Trailer with Diesel Fuel	9-3
9.4.2 Filling Machinery Using 12 Volt Electric Fuel Pump	9-4
9.4.3 Filling Machinery Using Gasoline Powered Fuel Pump	9-5
9.4.4 Filling the Trailer's DEF Tank	9-7
9.4.5 Filling the DEF Tank on Machinery	9-7
9.5 DEF Solution	9-9
9.5.1 DEF Solution Safety Practices	9-9
9.5.2 First Aid Measures	9-9
9.5.3 General Information.	9-9
9.5.4 Storage	9-10
9.5.5 Using DEF	9-10
9.5.6 DEF Disposal	9-10
10. STORAGE	10-1
10.1 General Information	10-1
10.2 Placing in Storage.	10-1
10.3 Removing from Storage.	10-1
10.4 Winterizing the DEF System	10-1
11. MAINTENANCE	11-1
11.1 Safety	11-1
11.1.1 General Safety	11-1
11.2 Wheel Bearings	11-2
11.3 Battery.	11-2
11.3.1 Battery Safety.	11-2
11.3.2 Battery Replacement and Maintenance Tips	11-2
11.3.3 Battery Maintenance	11-3
11.4 Fuses	11-3
11.5 Gasoline Engine (Optional)	11-4
11.5.1 Approved Fuel	11-4
11.5.2 Engine Oil.	11-4
11.5.3 Change Engine Oil	11-4
11.5.4 Air Filter Inspection	11-5
11.6 Engine Circuit Protection	11-5
11.7 Changing Diesel Fuel Filter	11-6
11.8 Engine to Pump Connection (Gasoline Engine Option Only)	11-6
11.9 Trailer Breakaway System	11-6
11.9.1 Testing the Battery	11-6
11.9.2 Charging the Battery	11-7
11.9.3 Replacing the Battery.	11-7
11.9.4 Testing the System	11-7
11.10 Wheel Bolt Torque Requirements	11-7

11.11	Axle Bolts, Trailer Hitch Bolts, and Tank Hold-Down Bolts	11-7
11.12	Tank Replacement	11-8
11.13	Rear Mounted Tool Box	11-8
11.14	Optional Compressor	11-8
12.	SERVICE	12-1
12.1	Service Record Chart	12-1
12.2	Service Checks	12-2
12.2.1	Daily (8 Hours)	12-2
12.2.2	Weekly (50 Hours)	12-2
12.2.3	Semiannual (200 Hours)	12-3
12.2.4	Annually (400 Hours)	12-3
12.2.5	60 Months	12-4
12.3	Axles	12-5
12.3.1	First 200 Miles	12-5
12.3.2	3,000 Miles or 3 Months	12-5
12.3.3	6,000 Miles or 6 Months	12-5
12.3.4	12,000 Miles or 12 Months	12-5
12.4	Tires	12-5
12.5	Welding Repairs	12-5
12.6	DEF Tank Drain Plug	12-5
12.7	Door Light Switch	12-6
13.	OPTIONS	13-1
13.1	Rear Mounted Tool Box	13-1
14.	OEM LITERATURE	14-1
14.1	Gasoline Engine	14-1
14.2	DEF Pump	14-1
14.3	Diesel Fuel Pump	14-2
14.3.1	Electric Diesel Fuel Pump	14-2
14.3.2	Gasoline Diesel Fuel Pump	14-2
14.4	Generator/Welder/Compressor	14-2
14.5	Axle	14-2
15.	TROUBLESHOOTING	15-1
15.1	Troubleshooting Chart	15-1
16.	WARRANTY	16-1
16.1	Warranty Statement	16-1
17.	PARTS	17-1
17.1	Diesel Fuel Pump, Engine	17-2
17.2	Diesel Fuel Pump, 12VDC	17-3
17.3	DEF Pump Assembly	17-4
17.4	DEF Tank Assembly	17-5
17.5	Anti-Spill Inspection Manway	17-6
17.6	Generator/Welder/Compressor Option (3-In-1)	17-7
17.7	Generator/Compressor Option (2-In-1)	17-8
17.8	Decals and Safety Signs	17-9
17.9	Utility Box Assembly	17-10
17.10	Spare Tire Option	17-12
17.11	Cowling Assembly	17-13
17.12	Tandem Axle Trailer	17-14
17.13	Triple Axle Trailer	17-16
17.14	Utility Box and IBC (Tank)	17-18
17.15	Air and Electrical Dual Reel Option	17-19
17.16	First Aid Kit and Fire Extinguisher	17-19

2. INTRODUCTION

2.1 CONGRATULATIONS

Congratulations on your choice of a Meridian Manufacturing Inc. Fuel Trailer to complement your farming operation in Canada. This equipment has been designed and manufactured to meet the exacting standards of Transport Canada for such equipment in the Canadian agricultural industry and will keep your operation running at optimum efficiency.



The Fuel Trailer is designed to transport diesel fuel and diesel exhaust fluid (DEF) to your fueling location. If equipped with the optional 12 VDC Fill-Rite® fuel pump, gasoline can also be transported.

Safe, efficient, and trouble-free operation of your Fuel Trailer requires that you, and anyone who will be operating or maintaining the equipment, read and understand the Safety, Operation, Maintenance, and Troubleshooting information contained within this Operator's Manual and other OEM manuals, as applicable.

This manual covers the Fuel Trailer manufactured by Meridian Manufacturing Inc. for the Canadian market. Use the Table of Contents as a guide to locate required information.

WARNING



Do not fill or tow the unit until you read and understand the information contained in this manual.

2.2 OPERATOR ORIENTATION

The directions left, right, front, and rear, as mentioned throughout this manual, are as seen from the truck drivers' seat and facing in the direction of travel.

2.3 OWNER/OPERATOR

It is the responsibility of the owner or operator to read this manual and to train all other operators before they start working with the equipment. Follow all safety instructions exactly. Safety is everyone's business. By following recommended procedures, a safe working environment is provided for the operator, bystanders, and the area around the work site. Untrained operators are not qualified and must not operate the equipment.

In addition to the design and configuration of equipment, hazard control and accident prevention are dependent upon the awareness, concern, prudence, and proper training of personnel involved in the filling, operation, transport, maintenance, and storage of this equipment. It is the responsibility of the owner or operator to read this manual and to train all operators before they start working with the equipment. Follow all safety instructions as laid out in this manual.

Keep this manual handy for easy reference and to pass on to new operators or owners. Call your Meridian Manufacturing Inc. dealer if you need assistance, information, or additional copies of the manuals.

The information, specifications, and illustrations in this manual are those in effect at the time of printing. We reserve the right to change specifications or design at any time without notice.

2.4 DISPOSAL OF EQUIPMENT AT END OF USEFUL LIFE

The Fuel Trailer has been designed for the specific purpose of transporting fuel and diesel exhaust fluid (DEF) to your machinery using country roads, local highways, and on agricultural farm land. When this unit is no longer capable of performing its designed purpose, it should be dismantled and scrapped. Do not use any materials or components from this unit for any other purpose.

2.5 CONTINUOUS IMPROVEMENT PROCESS

Meridian's desire is to manufacture, for our customers, the best equipment possible. Because of our continuous improvement process, some images may be different than the actual product.

2.6 BEFORE STARTING GAS ENGINE

2.6.1 Door Keys

The door keys are attached to the DEF hose. Remove and secure them before using the fuel trailer.



2.6.2 Check Oil Level

Before starting the gasoline engine, if equipped, for the first time, check the engine oil level. Add oil as necessary.

NOTICE

Check the engine oil level and add as needed. Operating the engine without oil will damage the engine and void the warranty.



2.6.3 Prime Gasoline Engine Fuel Pump (Diesel Only)

This fuel pump is a self-priming centrifugal pump and only requires priming prior to its initial start. The pump will retain sufficient liquid for self-priming thereafter.



To prime the pump:

1. Remove fill plug (1) on top of the pump housing.
2. Fill the pump housing with filtered diesel fuel.
3. Replace the plug.

2.6.4 Prime DEF Pump

The DEF pump is a self-priming centrifugal pump. If the DEF tank is full, the pump will not require priming prior to its initial start. If the tank is partially filled, the pump may require priming prior to its initial start. The pump will retain sufficient liquid for self-priming thereafter.

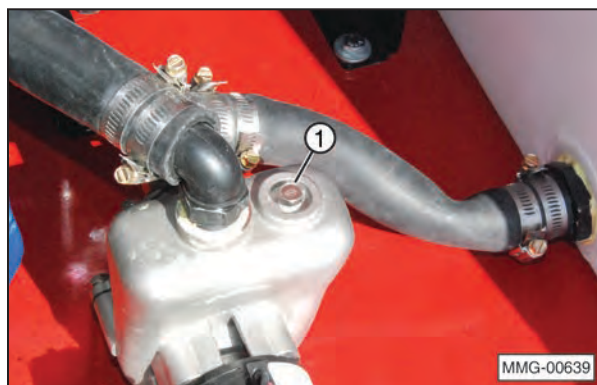

To prime the pump:

1. Remove fill plug (1) on top of the pump housing.
2. Fill the pump housing with filtered DEF.
3. Replace the plug.

3. SAFETY

SAFETY ALERT SYMBOL

This Safety Alert symbol means
ATTENTION! BECOME ALERT!
YOUR SAFETY IS INVOLVED!



The Safety Alert symbol identifies important safety messages on the Meridian Fuel Trailer Models and in the manual. When you see this symbol, be alert to the possibility of personal injury or death. Follow the instructions in the safety message.

WHY IS SAFETY IMPORTANT TO YOU?

3 Big Reasons

- Accidents Disable and Kill •
- Accidents Cost •
- Accidents Can Be Avoided •

SIGNAL WORDS:

Note the use of the signal words **DANGER**, **WARNING**, and **CAUTION** with the safety messages. The appropriate signal word for each message has been selected using the following guidelines:



CAUTION - Indicates a potentially hazardous situation that, if not avoided, may result in minor or moderate injury. It may also be used to alert against unsafe practices.



WARNING - Indicates a potentially hazardous situation that, if not avoided, could result in death or serious injury, and includes hazards that are exposed when guards are removed. It may also be used to alert against unsafe practices.



DANGER - Indicates an imminently hazardous situation that, if not avoided, will result in death or serious injury. This signal word is to be limited to the most extreme situations typically for equipment components which, for functional purposes, cannot be guarded.

If you have any questions not answered in this manual, require additional copies of the manual, or the manual is damaged, please contact your dealer or Meridian Manufacturing, Inc., 2902 Expansion Blvd., Storm Lake, Iowa, 50588, toll free 1-800-437-2334, phone (712) 732-1780, or fax (712) 732-1028.

3.1 ADDITIONAL SAFETY WORDS

NOTICE

Indicates that equipment or property damage can result if instructions are not followed.

SAFETY INSTRUCTIONS

Safety instructions (or equivalent) signs indicate specific safety-related instructions or procedures.

Note: Contains additional information important to a procedure.

3.2 SAFETY TRAINING

1. Safety is a primary concern in the design and manufacture of our products. Unfortunately, our efforts to provide safe equipment can be wiped out by a single careless act of an operator or bystander.
2. Know your controls and how to immediately stop the equipment in an emergency. Read this manual and the one provided with all auxiliary equipment.

YOU are responsible for the **SAFE** operation and maintenance of your Meridian Manufacturing Inc. Fuel Trailer. **YOU** must ensure that you and anyone else who is going to operate, maintain, or work around the Fuel Trailer be familiar with the operating and maintenance procedures and related **SAFETY** information contained in this manual. This manual will take you step-by-step through your working day and alert you to all good safety practices that should be adhered to while operating the Fuel Trailer system.









Remember, **YOU** are the key to safety. Good safety practices not only protect you but also the people around you. Make these practices a working part of your safety program. Be certain that **EVERYONE** operating this equipment is familiar with the recommended operating and maintenance procedures and follow all the safety precautions. Most accidents can be prevented. Do not risk injury or death by ignoring good safety practices.

- Fuel Trailer owners must give operating instructions to operators or employees before allowing them to operate the equipment, and then annually thereafter per OSHA (Occupational Safety and Health Administration) regulation 1928.57.
- The most important safety feature on this equipment is a **SAFE** operator. It is the operator's responsibility to read and follow **ALL** Safety and Operating instructions in the manual. Most accidents can be avoided.
- A person who has not read and understood all operating and safety instructions is not qualified to operate the equipment. An untrained operator exposes himself and bystanders to possible serious injury or death. Always be and stay alert to any possible unsafe operating or maintenance procedures or conditions.
- Do not modify the equipment in any way. Unauthorized modification may impair the function and/or safety of the components and systems and could affect the life of the equipment, possibly invalidating the warranty coverage.
- Think SAFETY! Work SAFELY!

3.3 SAFETY ICON NOMENCLATURE

Pictorial icons signal a type of hazard and warn of personal protection issues, prohibited actions, and hazard avoidance.

3.3.1 Personal Protection/Important Information

-  Read the manual
-  Damaged safety signs
-  Eye protection
-  Fire extinguisher
-  First aid kit
-  Hand protection
-  Head protection
-  Hearing protection
-  Inspect equipment
-  OEM parts only
-  Protective shoes
-  Remove key
-  Set parking brake
-  Stop engine
-  Think safety
-  Transmission in park
-  Use proper support
-  Use proper tools
-  Visibility
-  Weight rating

3.3.2 Prohibited Actions

-  Do not alter or modify
-  Do not ride
-  Do not weld
-  No alcohol
-  No drugs
-  No young children
-  No smoking
-  No open flame

3.3.3 Hazard Avoidance

-  Crush hazard
-  Crush hazard (chock wheels)
-  Defective or broken part
-  Entanglement hazard
-  Explosive force hazard
-  Fall hazard
-  Safety alert symbol
-  Slipping hazard
-  Tire pressure (maintain)
-  Tripping injury
-  Pinch point

3.4 GENERAL SAFETY





Read and understand the Operator's Manual and all safety signs before operating, maintaining, adjusting, filling, or towing the Fuel Trailer.

This trailer was designed for a specific application; transporting diesel fuel or gasoline, and diesel exhaust fluid (DEF). Only the optional 12VDC Fill-Rite® fuel pump is approved for gasoline. DO NOT modify or use this trailer for any application other than that for which it was designed.

Trailers that are filled or operated improperly or by untrained personnel can be dangerous, exposing themselves and/or bystanders to possible serious injury or death.

1.  Have a first aid kit available for use should the need arise and know how to use it.

2.  Have a fire extinguisher available for use should the need arise and know how to use it.

3.  Do not allow riders.

4. When working around or operating this equipment, wear appropriate personal protective equipment. This list includes but is not limited to:





- A hard hat.
- Protective shoes with slip resistant soles.
- Protective goggles, glasses, or face shield.
- Heavy gloves and protective clothing.
- Respirator, if necessary.

5.  Do not allow long hair, loose fitting clothing, or jewelry around equipment with rotating parts.

6.  Securely latch compartment doors before towing.

7.  Stop the gasoline fuel pump engine, remove ignition key, and wait for all moving parts to stop before servicing, repairing, adjusting, filling, or towing.

8.  Clear the area of people, especially small children, before refueling machinery.

9.  Review safety related items annually with all personnel who will be operating, using, or maintaining the Fuel Trailer.

10.  Provide the end user with the owner/operator literature. Fuel Trailer owners must provide operating instructions to anyone using the trailer.

11.  Under no circumstances should young children be allowed to work with or around the Fuel Trailer.

12.  Under no circumstances should smoking or open flame be allowed around the Fuel Trailer.

13.  Do not attempt to fill, tow, or operate this trailer under the influence of drugs or alcohol. Consult your doctor before using this trailer while taking prescription medications.

14.  Hearing Loss – Prolonged Exposure To Loud Noise May Cause Permanent Hearing Loss!

Working environments with noise-producing equipment can cause permanent hearing loss. We recommend using hearing protection any time noise levels exceed 80db. Noise levels over 85db, on a long-term basis, can cause severe hearing loss. Noise levels over 90db over a period of time can cause permanent and even total hearing loss.

Hearing loss from loud noise is cumulative over a lifetime without hope of natural recovery.

Note: In order to provide a better view, certain photographs or illustrations in this manual may show an assembly with a safety shield removed. However, equipment should never be operated in this condition. Keep all shields in place. If shield removal becomes necessary for repairs, replace the shield prior to use.

3.5 SAFETY SIGNS

Refer to “4.3 Safety Sign Locations” on page 4-1 for safety information.

3.6 PREPARATION

Refer to “7. Pre-Operating Instructions” on page 7-1 for safety information

3.7 TRANSPORT SAFETY

Refer to “8. Towing” on page 8-1 for safety information.

3.8 STORAGE SAFETY

Refer to “10. Storage” on page 10-1 for safety information.

3.9 OPERATING SAFETY

Refer to “9. Operation” on page 9-1 for safety information.

3.10 MAINTENANCE SAFETY

Refer to “11. Maintenance” on page 11-1 for safety information.

3.11 DIESEL FUEL SAFETY

Refer to Appendix A for additional safety information on gasoline and diesel fuel.

3.11.1 Inhalation Hazard



Always avoid breathing fuel vapors or mists which may cause dizziness, drowsiness, moderate eye irritation, and/or skin irritation (rash). Excessive exposure may cause irritations to the nose, throat, lungs, and respiratory tract. Central nervous system (brain) effects may include headache, dizziness, loss of balance and coordination, unconsciousness, coma, respiratory failure, and death.

In case of inhalation, move the person to fresh air. If the person is not breathing, provide artificial respiration. If necessary, provide additional oxygen once breathing is restored if trained to do so. Seek medical attention immediately.

3.11.2 Fire and Explosion Hazards



Diesel fuel presents a moderate fire hazard. Vapors may be ignited rapidly when exposed to heat, spark, open flame, or other source of ignition. When mixed with air and exposed to an ignition source, flammable vapors can burn in the open or explode in confined spaces. Being heavier than air, vapors may travel long distances to an ignition source and flash back. Runoff to sewer may cause fire or explosion hazard.

If a fire occurs during refuelling:

- Leave the nozzle in the tank and back away.
- Notify the proper authorities.

3.11.3 Static Electricity Hazard

Under certain conditions, liquids, solid objects, and people can become charged with static electricity. If these charges cannot move or flow to ground, the static charges continue to accumulate, and will eventually develop enough energy to jump as a spark to another nearby object. If flammable gas or vapor is present when this occurs, this spark can ignite a fire or cause an explosion.

Before pumping fuel, touch any metal on the fuel trailer or vehicle being fueled, away from the fuel filler, with your bare hand. This will discharge any static electricity on your body. Failure to fully discharge may ignite fuel vapors.

Do not enter the implement cab while fuelling. Sliding across the seat can create a static charge which may ignite vapors.

- Always turn the engine off before fuelling the vehicle.
- Do not enter the vehicle being fuelled.
- Do not smoke while fuelling.
- Do not use electronic devices, which can cause an electrical spark while fuelling.
- Fill the vehicle fuel tank no more than 95% full to allow for expansion.

3.11.4 Ingestion

WARNING



The major health threat of ingestion occurs from the danger of aspiration (breathing) of liquid drops into the lungs, particularly from vomiting. Aspiration may result in chemical pneumonia (fluid in the lungs), severe lung damage, respiratory failure, and even death. Ingestion will cause gastrointestinal disturbances, including irritation, nausea, vomiting and diarrhea, and central nervous system (brain) effects similar to alcohol intoxication. In severe cases, tremors, convulsions, loss of consciousness, coma, respiratory arrest, and death may occur.

In case of ingestion **DO NOT INDUCE VOMITING**. Do not give liquids. Obtain immediate medical attention. If spontaneous vomiting occurs, lean victim forward to reduce the risk of aspiration. Monitor for breathing difficulties.

Small amounts of material which enter the mouth should be rinsed out until the taste is dissipated.

3.11.5 Eye Protection

WARNING



Safety glasses or goggles are recommended where there is a possibility of splashing or spraying. Contact with liquid or vapor may cause mild irritation.

In case of contact with eyes, immediately flush with clean, low-pressure water for at least 15 minutes. Hold eyelids open to ensure adequate flushing. Seek medical attention.

3.11.6 Skin Protection

CAUTION



Contact with diesel fuel may cause skin irritation with prolonged or repeated contact. Wearing gloves constructed of nitrile, neoprene, or PVC are recommended when in close contact with diesel fuel. Chemical protective clothing should also be worn. Long-term, repeated exposure to diesel fuel may cause skin cancer.

In case of contact with skin, remove contaminated clothing. Wash contaminated areas thoroughly with soap and water or waterless hand cleanser. Obtain medical attention if irritation or redness develops.

3.11.7 Storage Precautions

CAUTION



Keep away from flame, sparks, excessive temperatures, and open flame. Keep trailer fill port closed because an empty tank may contain explosive vapors. Do not pressurize, cut, heat, weld, or expose tanks to sources of ignition.



Store the trailer in a well-ventilated area. Avoid storage near incompatible materials.

3.11.8 U.S. Federal, State, and Local Regulatory Information

SAFETY INSTRUCTIONS



Diesel fuel is on the EPA TSCA Inventory. Any spill or uncontrolled release of this product, including any substantial threat of release, may be subject to federal, state and/or local reporting requirements. This product may also be subject to other regulations at the state and/or local level. Always consult the regulations applicable to your area prior to operation.

3.11.9 Canada Regulatory Information

The tank is registered by Transport Canada as a UN Standard Mobile IBC and is in compliance for shipment of Class 3 - Packing Groups II and III. In compliance with the testing requirements specified by Transport Canada, the IBC has been tested to specification CAN/CGSB-43.146-2002, which includes leak, hydraulic pressure, drop, vibration, and roll-over testing. Testing was to the Packing Group II standard.

3.11.10 Spill Reporting

Every province and territory requires persons involved in spills of hazardous substances and environmental contaminants to report those spills as soon as possible. Some provinces limit this obligation to only spills that actually harm the environment. Other provinces require reports only when the amount spilled reaches a certain limit. In addition, the rules vary in terms of which parties must report.

Failing to report a spill can lead to fines and other penalties. Reporting requirements are strictly enforced and backed by significant penalties, even when the spill involved appears to be a minor one.

3.12 BATTERY SAFETY

3.12.1 General Hazards

SAFETY INSTRUCTIONS

Wear protective eye wear and gloves.

DO NOT attempt to recharge a frozen battery. Remove the battery from the vehicle/equipment, bring it into a warm room, and let it thaw before charging or testing.

Inspect the battery cables to make sure they are free of rust and corrosion and have no exposed wires. Never use electrical tape to cover exposed wires.

Automotive lead-acid batteries contain sulfuric acid in the electrolyte. The acid inside the battery is highly corrosive and can burn your skin if it leaks out of the battery and gets on your skin. Acid may leak out of the battery if the case is cracked or damaged.

Maintenance-free batteries should always remain in an upright position (do not turn it sideways or upside down).

SAFETY INSTRUCTIONS

On equipment with a battery designed into the fuel trailer, it is usually a good idea to disconnect the battery before doing electrical repairs. Disconnect the battery negative lead from the battery to prevent accidental damage to onboard electronics or wiring to prevent a short circuit.

3.12.2 Ventilation Hazard

SAFETY INSTRUCTIONS

Whenever servicing a battery, work in a well ventilated area to prevent gas buildup.

3.12.3 Shock Hazards

SAFETY INSTRUCTIONS

Batteries only produce 12 Volts so there is NO danger of being shocked. However, 12 Volt batteries can generate several hundred amps of current, which is roughly the amount of current used by a welding arc. Do not short the battery by touching the positive or negative terminals with a metal tool. This current is capable of damaging tools, equipment, and causing personal injury. It can also cause the battery to explode.

Before working around a battery, remove all jewelry, particularly rings and necklaces. The electrical charge from a battery can be transmitted through a metal tool and into a metal ring or watch.

NEVER disconnect a battery when the ignition is ON in the tow vehicle, or while the engine is idling or running, as this can damage electrical and/or electronic components in the tow vehicle.

3.12.4 Explosion Hazards

**SAFETY
INSTRUCTIONS**

Always remove the battery's ground cable (black) before removing the positive (red). If the negative cable is removed first, it will not be possible to inadvertently complete a circuit, thus causing electrical shock.

A short circuit can occur if the positive terminal is connected to the battery and the person working with the battery comes into contact with a grounded object. Always remove the ground cable first.

Do not smoke around a battery, or use anything that produces an open flame or spark.

Batteries can explode. Batteries give off hydrogen gas, which is flammable and can explode if a spark occurs near the battery (as when connecting a jumper cable).

3.13 SIGN-OFF FORM

Meridian Manufacturing Inc. follows the general Safety Standards specified by the American Society of Agricultural Engineers (ASAE) and Occupational Safety and Health Administration (OSHA). Anyone who will be operating and/or maintaining the Meridian Manufacturing Inc. Fuel Trailer must read and clearly understand ALL Safety, Operating, and Maintenance information presented in this manual.

Do not allow anyone to operate this equipment until such information has been reviewed. Annually review this information before the season start-up.

Make these periodic reviews of SAFETY and OPERATION a standard practice for all of your equipment. We feel an untrained operator is unqualified to operate this equipment.

A sign-off sheet is provided for your recordkeeping to show that all personnel who will be working with the equipment have read and understand the information in the Operator’s Manual and have been instructed in the operation of the equipment.

SIGN-OFF FORM		
Date	Employee’s Signature	Employer’s Signature

4. SAFETY SIGNS

4.1 GENERAL INFORMATION

The types of safety signs and locations on the equipment are shown in the following pages. Good SAFETY AWARENESS requires that you familiarize yourself with the various safety signs, the type of warning and the area, or a particular function related to that area.

- 
 If safety signs have been damaged, removed, become illegible, or parts replaced without signs, new signs must be applied.
- Replacement parts that displayed a safety sign should also display the current sign.
- Replacement safety signs (labels) are available from your authorized Dealer Parts Department or the factory at no cost.

4.2 HOW TO INSTALL SAFETY SIGNS

- Be sure that the installation area is clean and dry.
- Be sure the temperature is above 50°F (10°C).
- Determine the exact position before you remove the backing paper.
- Remove the smallest portion of the split backing paper.
- Align the sign over the specified area and carefully press the small portion with the exposed sticky backing in place.
- Slowly peel back the remaining paper and carefully smooth the remaining portion of the sign in place.
- Small air pockets can be pierced with a pin and smoothed out using a piece of sign backing paper.

4.3 SAFETY SIGN LOCATIONS

- Safety Decal on Anti-Siphon Valve.



MMG-00575

- Product Serial Number Decal (#19984).



- WARNING — Read and Understand (#17553) (located inside driver's side compartment door).



AR

To prevent serious injury or death
Read and understand operator's Manual before using. Review safety instructions annually.
Do not use fuel trailer for any purpose other than its intended use transporting diesel fuel and DEF solution.

Keep working area clean and free of spills and debris to prevent slipping or tripping. Do not allow riders on trailer or fuel tank when transporting.
Do not place hands, arms or body between stationary and moving objects.
Do not stand on any part of trailer. Do not use fuel tank as a work platform.
Do not allow compartment doors to swing open freely.

Do not smoke when refuelling gasoline engine, filling trailer's diesel fuel tank or refueling machinery.
Stop and turn off machinery before refueling.

Do not weld on any part of fuel trailer. Welding sparks can cause an explosion.

Do not tow fuel trailer with gasoline engine running.
Follow all State, Federal health and safety laws and or local regulations when filling machinery or transporting diesel fuel.
Before towing, securely attach hitch to tow vehicle. Install hitch retainer clip, connect safety chains, attach breakaway brake cable, connect wiring harness, and make sure taillights are functioning.

AR

To prevent serious injury or death
Stop gasoline engine, remove starter key and wait for all moving parts to stop before servicing, repairing, adjusting or towing trailer or refueling gasoline engine.
Obey all local regulations for the use and disposal of diesel fuel and or DEF solution.

Flammable fluid (gasoline, diesel fuel or engine oil) leaked or spilled onto hot surfaces can cause a fire. Clean up all leaked or spilled fluid immediately. Sparks or open flames can cause flammable fluid to ignite. Do not smoke while working on or near any flammable fluid.
Do not store flammable or caustic substances inside engine compartment.

Keep sparks, lit matches and open flames away from top of battery because battery gas can explode. Always follow safety recommendations when working near battery.
Automotive batteries contain sulfuric acid and can produce explosive gases. To prevent ignition of these gases, keep sparks, open flames, lit tobacco or any other ignition sources away from battery at all times. Do not allow jumper cables to contact each other or any metal surface. Battery fumes can ignite resulting in an explosion and personal injury or death.

Engine does not recharge battery. Manually recharge battery periodically.

Inspect hoses and pipes for leaks prior to each use. If found, immediately discontinue use of trailer until leak is repaired.

WARNING

EXHAUST FUMES HAZARD



Engine exhaust contains products of combustion which are harmful to your health and can cause death. Always start and operate engine in a well ventilated area. Do not operate engine inside of an enclosed area or building.

WARNING

EXPLOSION FUMES HAZARD



Take precautions to avoid sparks from battery coming into contact with fuel or fumes from gasoline engine's fuel tank or the trailer's fuel tank. Sparks will cause an explosion of combustible fuel fumes resulting in serious injury or death.

4. United Nations Primary Marking tag.



5. UN IBC Additional Marking tag.

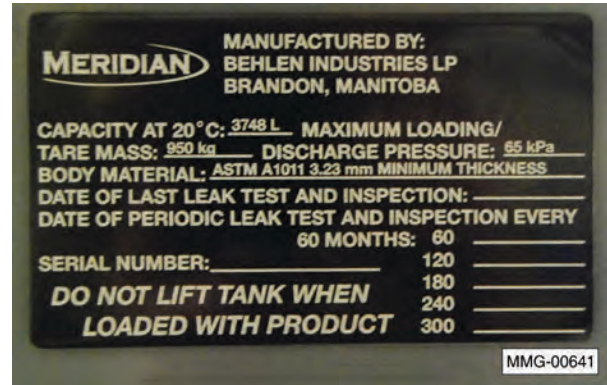

6. Safety Decal on Gasoline Engine (contact OEM supplier for replacement).



7. Safety Decal on Option Air Compressor/Welder Unit (contact OEM supplier for replacement).

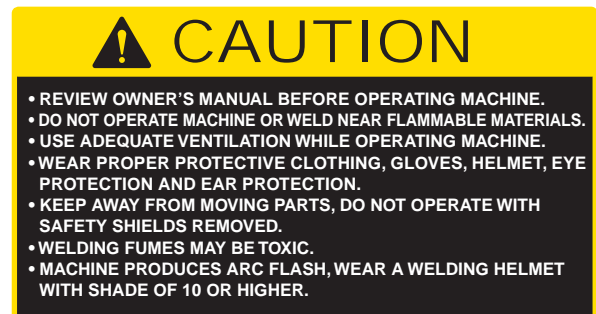

8. Safety Decal on Fuel Pump (contact OEM supplier for replacement).



9. Safety Decal on 2" Fill Spout.



10. Maintain Air Cleaner on gasoline engine — (contact OEM manufacturer for replacement of this decal).

MAINTAIN AIR CLEANER

Clean up in cleansing solvent and dry up once every 50 hours (every 10 hours in unusually dusty circumstances) and then immerse in clean engine oil until saturated, squeeze out excessive oil.

4.4 INSTALLING FUEL PLACARDS

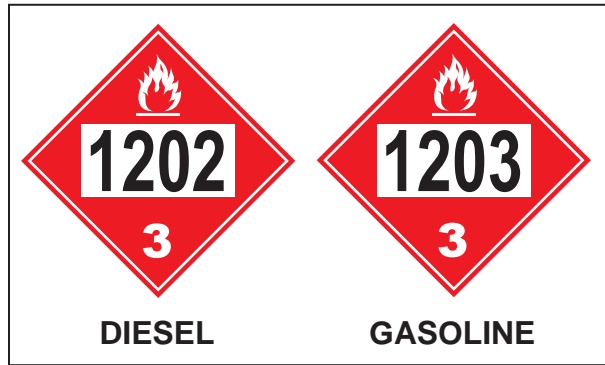

SAFETY INSTRUCTIONS

 Before transporting fuel, make sure the fuel placards are displayed on all four sides of the trailer. It is the responsibility of the owner to properly install and display these placards.

Fuel trailers are shipped with four UN 1202 diesel fuel placards that are not installed. Federal regulations require that the placards be installed before filling the tank with diesel fuel.



Note: The supplied fuel placards may differ from those illustrated.



If the fuel trailer is used for any other acceptable fuel, the appropriate placards must be installed.

Note: Only the optional 12VDC Fill-Rite® fuel Pump is approved for gasoline.

Install one placard on each of the four sides. If an optional tool box is installed, place the placard on the door of the tool box.

Note: The end user must install the placards prior to filling the fuel tank with diesel fuel. Trailers that have never been filled with fuel do not require the placards in order to be towed.

4.4.1 Emergency Response

In case of an emergency fuel spill, contact CANUTEC, which provides a 24 hour national bilingual (French and English) emergency response advisory service by calling 613-996-6666 or 666 (STAR 666) cellular (in Canada only). Collect calls are accepted.

In case of a fuel spill in the U.S., contact the United States National Response Center (NRC).

The NRC, which is operated by the U.S. Coast Guard, receives reports required when dangerous goods and hazardous substances are spilled. After receiving notification of an incident, the NRC will immediately notify the appropriate Federal On-Scene Coordinator and concerned Federal agencies. Federal law requires that anyone who releases into the environment a reportable quantity of a hazardous substance (including oil when water is, or may be affected) or a material identified as a marine pollutant, must immediately notify the NRC. When in doubt as to whether the amount released equals the required reporting levels for these materials, the NRC should be notified.

CALL NRC (24 hours) 1-800-424-8802 (Toll-free in the U.S., Canada, and the U.S. Virgin Islands) or 202-267-2675 in the District of Columbia.

5. SPECIFICATIONS

5.1 OVERALL DIMENSIONS

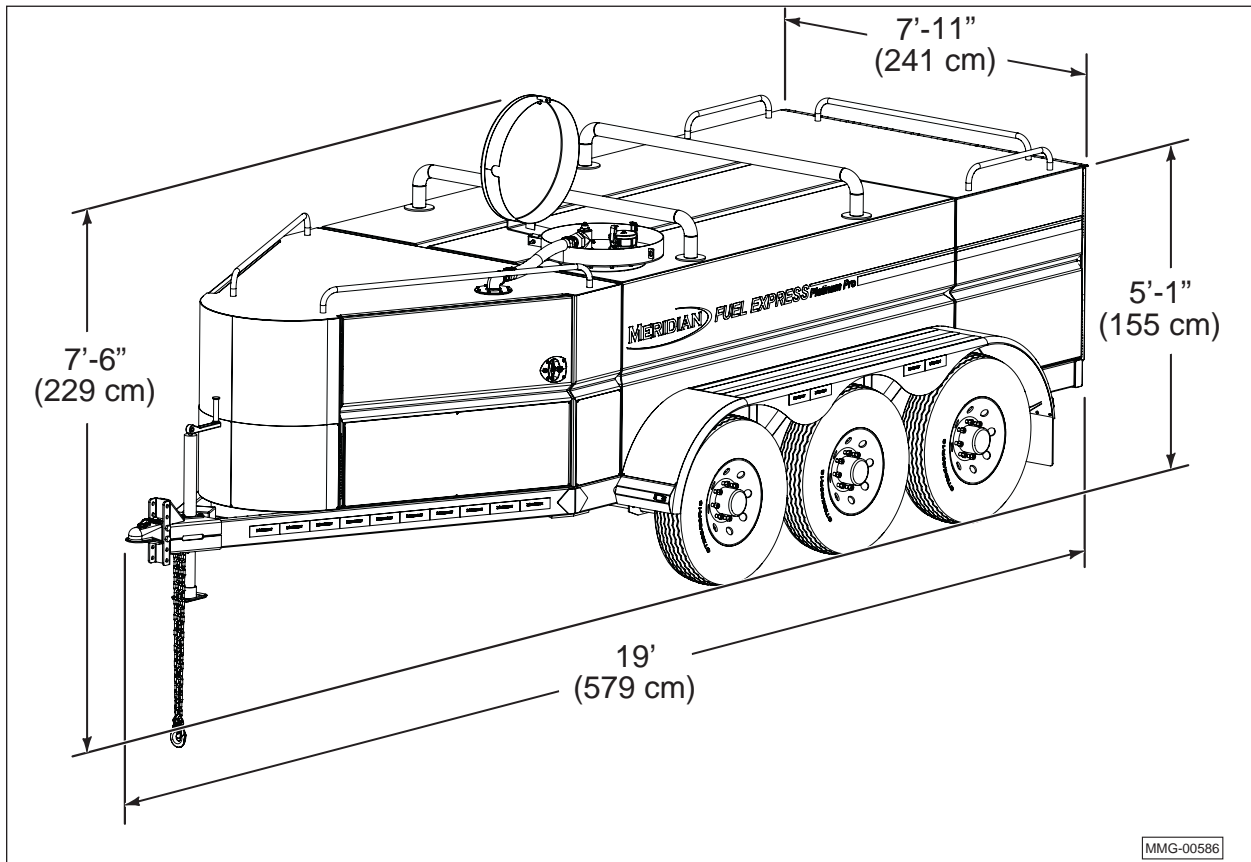
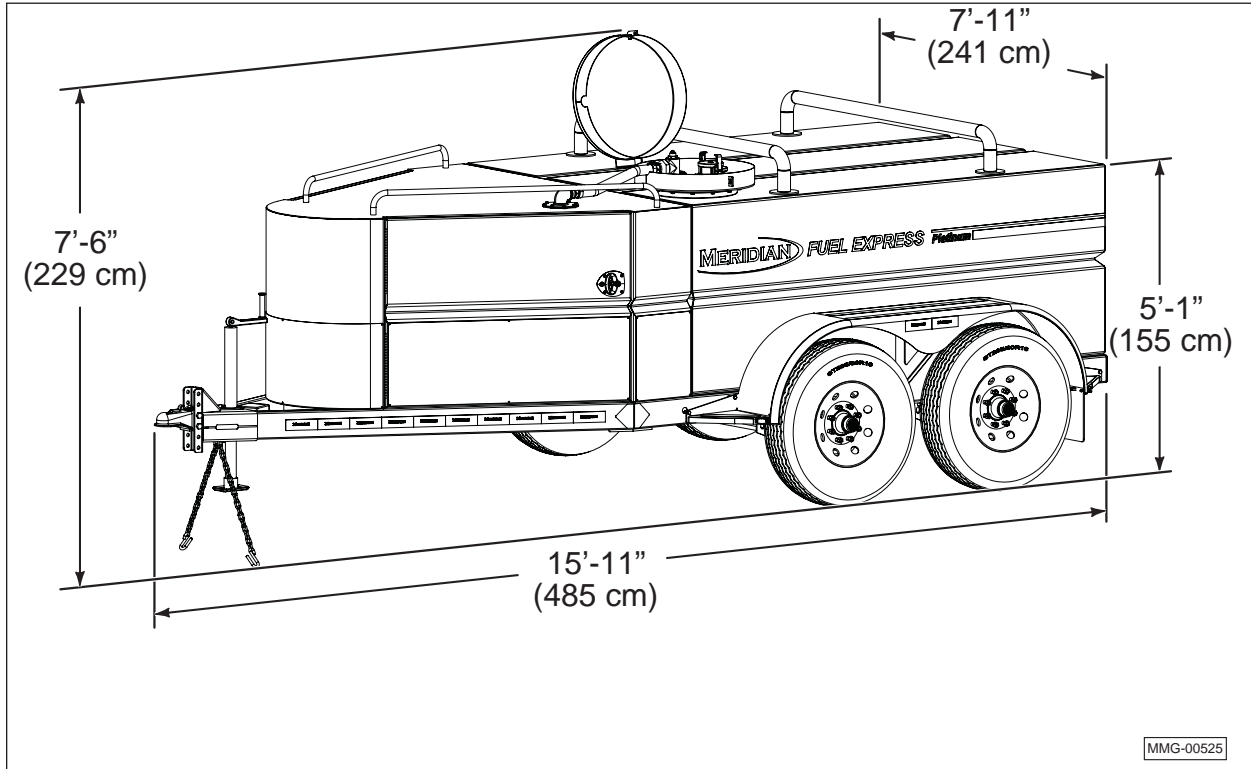

5.2 SPECIFICATIONS

Description	Specification
Gasoline Engine Option	6.5 horsepower Electric start Low-oil sensor One-year manufacturers warranty from OEM
Fuel Pump	40 gpm
Fuel Hose	35' or 50' long hose on retracting reel with automatic shut-off nozzle
Filter (diesel fuel)	10 Micron
Electric (12 Volt) Pump Option	Power – DC 12 Volt Size – 1/2 horsepower Duty cycle – 30 minutes Thermal protection switch Circuit protection fuse Flow — 25 gpm
DEF Solution Pump	Power – 12 Volt Flow – up to 25 gpm
DEF Hose	25' long hose on retracting reel with automatic shut-off nozzle
DEF Solution Tank Capacity	55 or 110 gallon poly tank options
Electrical System	Battery (12 Volt) for engine's electric start, DEF pump and 12VDC fuel pump
Standards	Class 3 Liquids – Packing Groups II and III
Acceptable Liquids (Canada)	DEF and dangerous liquids (Class 3 – Packing Groups II and III) which include gasoline, E15, and diesel fuel up to Bio 20
Acceptable Liquids (US)	Diesel fuel up to Bio 20, Gasoline, E15
UN Standards Compliance	CGSB-43.146
UN Standards Classification	31A/W (steel tank for liquids)
Registration	Transport Canada



Description	Specification
Trailer	
Axles and Tires	Two or three 7000 pound axle with electric drum brakes (each axle) 16" x 10-ply tires
Breakaway Brake System	Standard
Wiring Harness	Standard 7-pin automotive connector
Hitch	Adjustable height ball hitch (2 -5/16 inch)
Jack Stand	Top wind style
Safety Chains	Certified 3/8" Chain - 24,000 lb. rating
On-highway Trailer Lights	All lighting meets on-highway standards including license plate light
Front Storage Cowling Lighting	LED lighting which illuminates when either side door is opened
IBC Tank	
Rollover Protection	Standard
Anti-Spill Inspection Manway	Houses the 3" camlock fill port, 2" vent/fill cap, fuel level gauge, and 1-1/2" anti-siphon fuel discharge port, hinged and lockable lid, 3/4" NPT reclamation port
Frame Mounting	Bolted
Diesel Fuel Tank Capacity	3750 Liters (825 Imperial gallons)

5.3 BOLT SPECIFICATIONS

⚠ WARNING

EQUIPMENT FAILURE
 The torque value for bolts and capscrews are identified by their head markings. Replacing higher “Grade” bolts (Grade 8) with lower Grade bolts (Grade 5) will lead to equipment failure and can result in injury or death. Always use replacement bolts with the same Grade markings as the removed bolt.

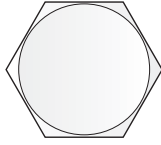
5.3.2 Grade Markings Chart

 No Marking	Grade 2 Low or Medium Carbon Steel
 3 Radial Lines	Grade 5 Medium Carbon Steel Quenched and Tempered
 6 Radial Lines	Grade 8 Medium Carbon Alloy Steel, Quenched and Tempered

5.3.1 Bolt Torque Values

Torque figures indicated below are valid for non-greased or non-oiled threads and heads unless otherwise specified. Therefore, do not grease or oil bolts or capscrews unless otherwise instructed in this manual. When using locking elements, increase torque values by 5%.

Bolt Diameter “A”	SAE Grade 2		SAE Grade 5		SAE Grade 8	
	N·m	(ft-lbs)	N·m	(ft-lbs)	N·m	(ft-lbs)
1/4"	8	(6)	12	(9)	17	(12)
5/16"	13	(10)	25	(19)	36	(27)
3/8"	27	(20)	45	(33)	63	(45)
7/16"	41	(30)	72	(53)	100	(75)
1/2"	61	(45)	110	(80)	155	(115)
9/16"	95	(70)	155	(115)	220	(165)
5/8"	128	(95)	215	(160)	305	(220)
3/4"	225	(165)	390	(290)	540	(400)
7/8"	230	(170)	570	(420)	880	(650)
1"	345	(225)	850	(630)	1320	(970)

6. EQUIPMENT COMPONENTS AND CONTROLS

6.1 COMPONENT NOMENCLATURE AND LOCATION

The Fuel Trailer is designed to transport diesel fuel, gasoline, and diesel exhaust fluid (DEF) to your fueling location.



- (1) Adjustable height hitch for 2-5/16" ball.
- (2) Safety towing chains. (3) Top-wind jack stand.
- (4) Compartment for gasoline or electric fuel pump and DEF solution pump. (5) Anti-spill inspection manway.
- (6) 7000 lb axles with standard or aluminium wheels.
- (7) Optional tool box. (8) IBC fuel tank roll bars.

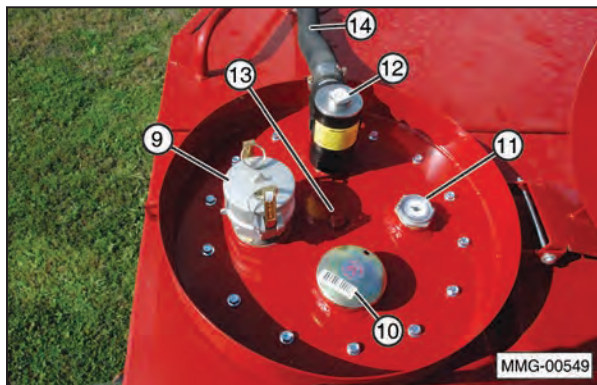

- (9) 3" camlock fill port. (10) 2" vent/fill cap. (11) Fuel level gauge. (12) 1-1/2" anti-siphon fuel discharge port.
- (13) 3/4" NPT reclamation port. (14) Hose to fuel pump. Hinged, lockable cover (not visible).



- (15) DOT compatible taillights and turn signals.
- (16) License plate light. (17) Red and white reflective tape. (18) Red safety lights.

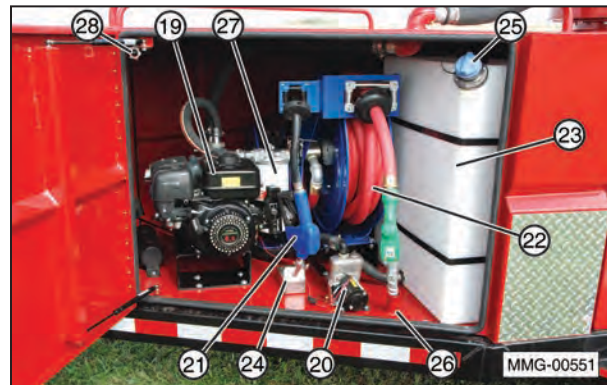

- (19) Electric start gasoline engine and diesel fuel pump.
- (20) 12 Volt electric pump DEF pump. (21) DEF solution hose and retractable reel with auto shut-off nozzle.
- (22) Diesel fuel hose and retractable reel with auto shut-off nozzle. (23) DEF solution tank. (24) DEF nozzle holder with catch basin. (25) DEF tank fill port.
- (26) Diesel fuel nozzle holder. (27) Diesel fuel tank fuel filter. (28) Interior lighting ON/OFF switch (turns on when door is opened).



(29) Breakaway brake system. (30) Wiring harness with 7-pin automotive connector.



(31) Optional front tool box. (Style varies).

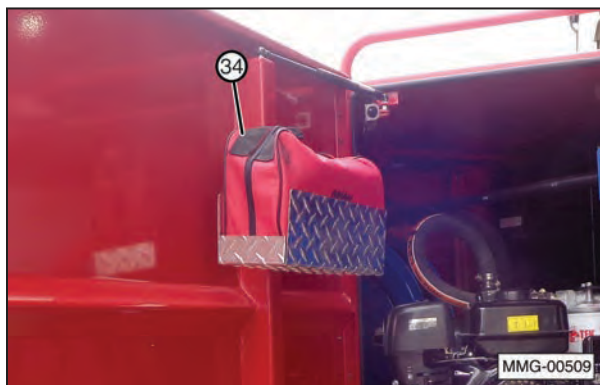

(32) Emergency safety kit.



(33) Battery box. (34) Literature tube.

6.2 GASOLINE ENGINE AND CONTROLS

(Not applicable to units with electric fuel pumps). Always read the OEM engine Operator's Manual supplied with the fuel trailer for the detailed engine operating procedures.

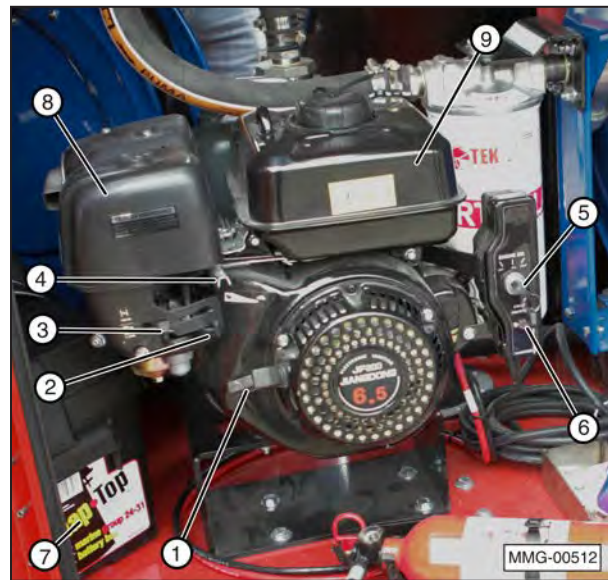

(1) Starting rope. (2) Fuel shut off lever (open to the right and closed to the left, facing unit). (3) Choke lever (open to the left and closed to the right, facing unit). (4) Throttle lever. (5) Engine key switch. (6) Engine circuit protection indicator. (7) Battery box and battery. (8) Air cleaner. (9) Gasoline tank.

1. Starting Rope

This retracting rope and T-bar is an optional method used to start the engine. Grasp the T-bar firmly and pull the rope sharply to start the engine. The key on the master control must be ON for the engine to start.

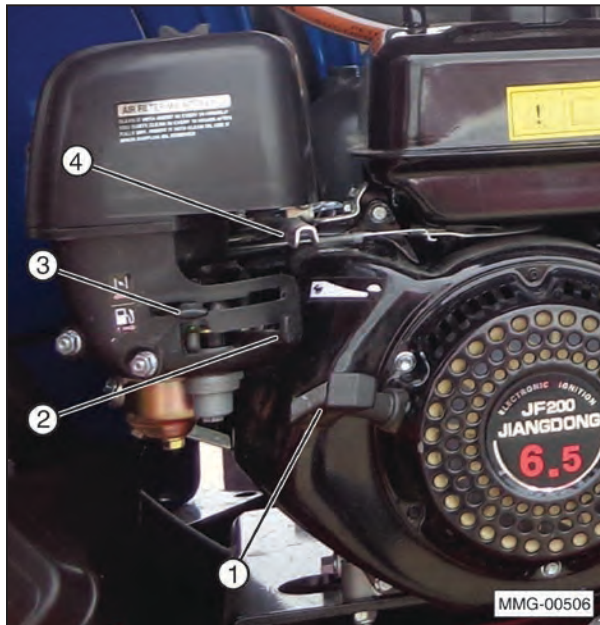

2. Fuel Shut-Off Lever

Each engine is equipped with a fuel valve between the fuel tank and the carburetor. The fuel valve lever must be in the ON position (to the right) for the engine to run. Slide the fuel valve toward the engine to turn ON and away for OFF (to the left).

Before transporting, or when the engine is not in use, move the fuel valve lever to the OFF position to prevent carburetor flooding and to reduce the possibility of fuel leakage.

3. Choke Lever

The choke lever controls the fuel/air mixture to the engine. Close the choke when starting if the engine is cold. Open the choke as the engine warms. Always open the choke fully during operation.

4. Throttle Lever

This lever controls the engine RPM. Move the lever to increase or decrease the RPM. The engine RPM controls the pump speed. Adjust the throttle from 1/2 to full to obtain the desired fuel flow.

5. Engine Key Switch

Turn the key switch to the START position to start the engine. When the engine starts, then release the key and allow it to return to the ON position.

6. Engine Circuit Protection

The circuit protector protects the battery charging circuit. A short circuit, or a battery connected with reverse polarity, will trip the circuit breaker. The green indicator inside the circuit protector will pop out to show that the circuit protector has switched off.



7. Battery (12 Volt)

A 12 Volt deep cycle battery supplies the power to start the gasoline engine or operate the 12 Volt electric diesel pump. If the tow vehicle is properly wired, the battery receives a trickle charge whenever the tow vehicle is running. Depending on the amount of use, the battery may still need to be periodically charged from an external source to keep it fully charged. Check the battery's state of charge before using the 12 Volt fuel pump.

Note: With the 12 Volt diesel fuel pump option, the battery will operate the pump for approximately 30 minutes.

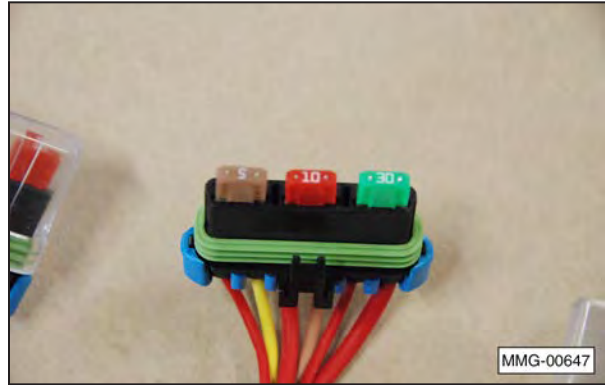

MMG-00647

Older fuel trailers have regular ATO/ATC fuses located within a control box inside the battery box.



MMG-00554



MMG-00600

10. Fuses

Several fuses protect the electrical system of the trailer and its components.

Newer fuel trailers have harness mounted fuse holders that accept mini APM/ATM fuses.

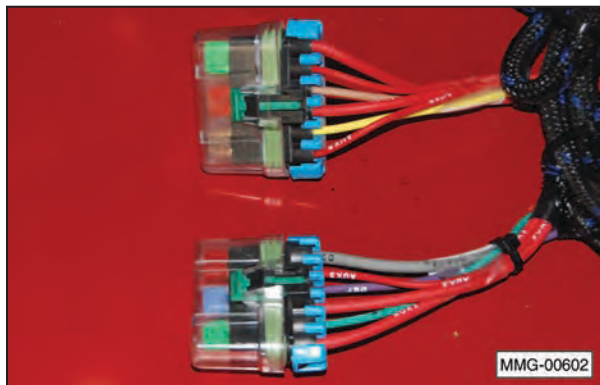

MMG-00602

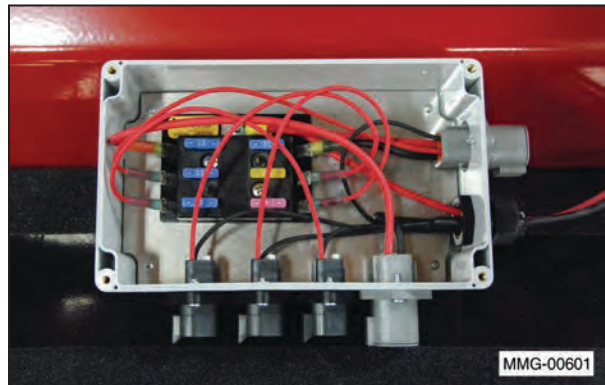

MMG-00601

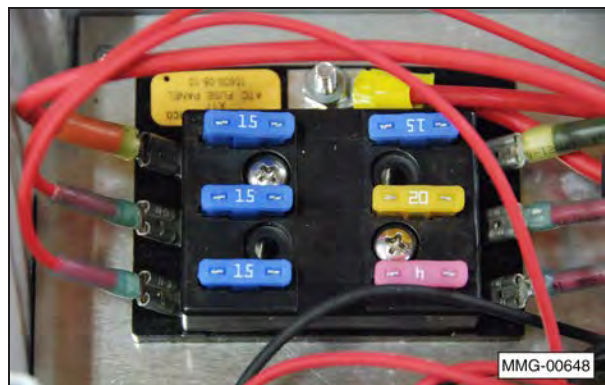

MMG-00648

7. PRE-OPERATING INSTRUCTIONS

7.1 EQUIPMENT BREAK-IN PERIOD

A special break-in procedure has been developed to ensure the integrity of the fuel trailer when first put into service. Follow the instructions and then follow the inspections for 1/2, 5, and 10 hour inspections at the appropriate interval.

After completing these instructions, follow the normal service schedule in the Maintenance and Service sections and engine manual.

1. Read and follow the instructions in the OEM engine, DEF pump, and the Meridian Operator's Manuals.
2. Before starting the gasoline engine for the first time, check the engine oil level. Add oil as necessary. Operating the engine without oil will damage the engine and void the warranty.

NOTICE

Check the engine oil level and add as needed. Operating the engine without oil will damage the engine and void the warranty.



3. Make sure the fuel pump is primed. To prime the pump:
 - a. Remove the fill plug on top of the pump housing.
 - b. Fill the pump housing with the diesel fuel to be pumped.
 - c. Replace the plug.
4. Start the engine and check the controls. Be sure that they function properly. The pump will take approximately one to two minutes to prime at half throttle.

5. Review and follow the Daily Pre-Operation Checklist "7.2 Daily Pre-Operation Checklist" on page 7-2 before starting the equipment.
6. Initially check the wheel bolt torque and then again at 10, 25, and 50 miles. Refer to "11.10 Wheel Bolt Torque Requirements" on page 58 for tightening instructions.



7.1.1 Inspections for 1/2, 5, and 10 Hours

1. On gasoline engine/pump combinations, recheck the engine to pump shaft connection after 1/2 hour and again after 4 hours.

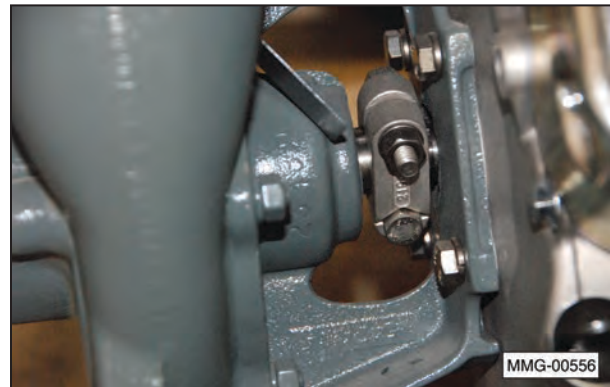

2. Recheck all hardware and fasteners after four hours of operation. Tighten to specified torque.

- At 10 hours, change the engine oil with the specified oil. Remove plug (2) to drain the oil and check the level with fill cap/gauge (1).

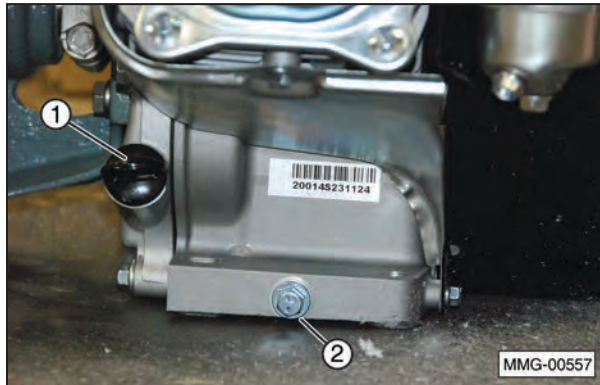

7.2 DAILY PRE-OPERATION CHECKLIST

Efficient and safe operation of the Fuel Trailer requires that each operator reads and follows the operating procedures and all related safety precautions outlined in this section.

A pre-operational checklist is provided for the operator. It is important, for both personal safety and maintaining the efficient operation of the delivery system, that this checklist be followed.

Before operating and each time thereafter, the following areas should be checked:

- Use only a truck or tractor of adequate power and weight to pull the trailer.
- Make sure the trailer is positively hitched to the tow vehicle.
- Attach safety chains from the trailer to the tow vehicle. Crisscross chains under the hitch to support it should an unplanned separation occur.
- Inspect wiring harness and plug for damage. Do not use trailer if damage is found.
- Check the engine oil and fuel levels. Add, as required.

IMPORTANT

The engine warranty is void if the engine is run without oil.

- Make sure the fuel level in the tank is sufficient to provide a steady flow of fuel. Do not run the pump dry. If the tank is run dry, the pump will not need to be re-primed. Full flow will be reached after one minute of operation. Refer to "9.4.1 Filling the Fuel Trailer with Diesel Fuel" on page 9-3.
 - Visually check all hardware and fasteners for missing parts and make sure the fasteners are properly tightened.
 - Make sure the wheel bolt lug nuts are properly tightened. Refer to "11.10 Wheel Bolt Torque Requirements" on page 11-7.
 - Check the tires and ensure they are inflated to their specified pressure. Correct under-inflation or over-inflation pressures. The specified inflation pressure is on the tires.
 - Remove any entangled crop material from under the trailer.
 - Test the breakaway brake unit and the trailer brakes. Refer to "11.9 Trailer Breakaway System" on page 11-6.
 - Make sure the trailer brakes are operating properly.
 - Make sure the trip wire to the breakaway switch is connected to the tow vehicle.
 - Make sure the key is correctly installed in the breakaway switch.
 - Press the Test button. The indicator should illuminate green. If the red light illuminates, the battery charge is low. Refer to the Trailer Breakaway System in the Maintenance section for instructions on charging the battery.
- Note:** The breakaway brake system is standard equipment. This system applies the brakes automatically and immediately whenever the breakaway cable is properly connected and the trailer separates from the tow vehicle.
- Make sure lights, reflectors, fuel placards, and SMV/SIS emblem required by local highway authorities are installed.

13. Clean and make sure taillights, signal lights, and side running lights are working properly.



Triple axle option.























Tandem axle option.



8. TOWING

8.1 TRANSPORT SAFETY

SAFETY INSTRUCTIONS

The following safety instructions are provided to help prevent injury or limit equipment damage.

1.  Comply with local, state, and federal laws governing safety and conveyance of farm related equipment on public roads.
2.  Always refer to the tow vehicle owner's manual Trailer Towing section to determine the vehicle's towing capacity and to ensure compatibility and maximum safety.
3.  Before attaching the trailer to the tow vehicle, be familiar with its controls and how to stop it quickly in the event of an emergency. Read and understand this manual and the one provided with your tow vehicle before towing the trailer.
4. Ensure that the trailer is equipped with brakes that are in good working order. Be familiar with their operation.
5.  Make sure the diesel fuel tank is securely fastened to the trailer before transporting.
6. Be sure the trailer is securely hitched to the tow vehicle and a retainer clip is inserted through the hitch. Always attach safety chains between the hitch and the tow vehicle.
7.  Stay away from electrical power sources. Electrocutation can occur without direct contact.
8. Plan your route to avoid heavy traffic.
9.  Do not drink and drive.
10. Be a safe and courteous driver. Yield to oncoming traffic in all situations, including narrow bridges, intersections, etc. Watch for traffic when operating near or crossing roadways.
11.   Never allow riders on the fuel trailer.
12.   Under no circumstances should young children be allowed to work with or around the Fuel Trailer. When moving the trailer, make sure all bystanders, especially small children, stay clear of the working area.
13.  Do not exceed a maximum safe travel speed, which may be lower than the recommended or posted speed. Slow down for corners and rough terrain.
14.  Shift towing vehicle to a lower gear before going down steep downgrades to use engine as a retarding force. Keep towing vehicle in gear at all times.
15.   If equipped, clean reflectors, SMV or SIS sign, and lights before towing. Make sure all the lights and reflectors required by highway and transport authorities are in place and can be seen clearly by all overtaking and oncoming traffic.
16.  Make sure all local, state, and federal regulations, regarding the transport of equipment on public roads and highways, are met. Check with the local authorities regarding trailer transport on public roads. Obey all applicable laws and regulations.
17.  Make sure the hitch and hitch ball on the towing vehicle are rated greater than the trailer's "gross vehicle weight rating" (GVWR).
18.  Inspect the hitch and hitch ball for wear or damage. Make sure the hitch and coupling are compatible. DO NOT tow the trailer using a defective hitch or coupling.
19.  Connect and crisscross the chains under the hitch to support the hitch should an unplanned separation occur.
20.  If equipped, attach the breakaway cable to the rear of the towing vehicle. Do not attach the cable to the trailer hitch.
21.  Check the tires for high/low pressure, cuts, bubbles, damaged rims, or missing lug nuts. Do not use the trailer if any damage is found.

22.  Make sure the directional and brake lights on the trailer are connected and working properly.
23. Department of Transportation (DOT) and Transport Canada requires that all highway safety devices, such as fenders, mud flaps, and lighting, are properly installed and in working condition before using the trailer.
24.  A 3/4 ton or larger capacity truck should be used for towing.

8.2 CONNECTING THE TRAILER

WARNING



Ensure that all bystanders, especially small children, are clear of the working area. Ensure there is enough room and clearance to safely back up to the trailer.

1. On a flat surface, use the trailer jack to level the trailer.

WARNING



Towing the fuel trailer with diesel fuel, when it is not in a level position, could cause an upward force on the tongue, separating the trailer from the tow vehicle. Make sure the trailer is set up with downward pressure on the tongue assembly.

2. Adjust the height of the receiver to align with the tow ball or be lower than the tow ball. Once aligned, tighten both bolts to 70 ft-lb (95 N·m).



WARNING



The receiver must be bolted to the frame with two bolts. The use of only one bolt could cause the receiver assembly to separate from the trailer, resulting in injury or death to bystanders. Do not use the trailer if only one bolt is installed.

3. Remove retainer clip (1). Release or open the receiver by lifting locking lever (2) into the open position.

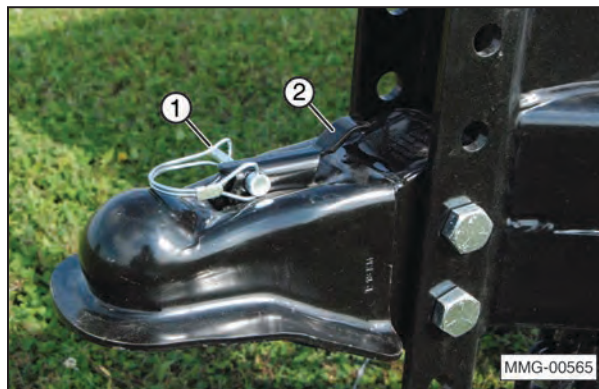

4. Using the jack, raise the hitch above the ball on the tow vehicle.
5. Slowly back the tow vehicle until the hitch and ball are aligned.
6. Lower the hitch onto the ball.

7. Raise the jack as far as it will go and place the handle in its stowed position.



8. Close the receiver lock lever and install the retainer clip to prevent unwanted opening of the receiver.

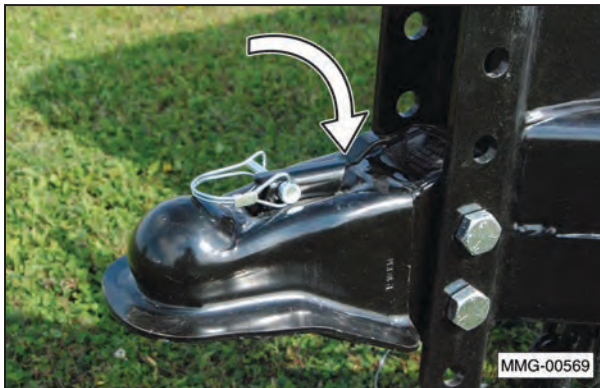

9. Attach safety chains (1) securely to the tow vehicle to prevent unexpected separation. Cross the chains when attaching.
10. Connect wiring harness (2) with the seven-pin connector for the lights and brakes.
11. Connect breakaway system cable (3) to the tow vehicle. Make sure key (4) on the end of the cable is properly plugged into the receiving unit.

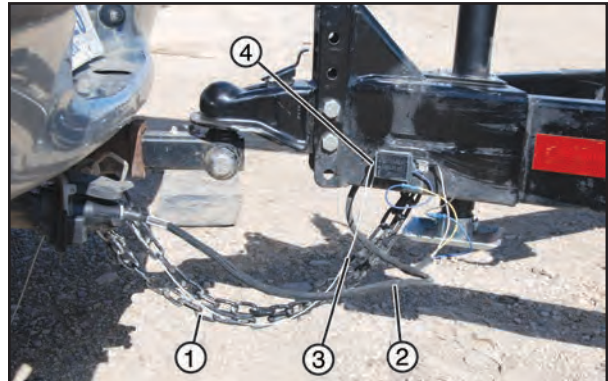

(The photo reflects a different trailer model; however, the hookup method is the same).



(The key must be completely plugged into the socket for the system to operate properly).

⚠️ WARNING



If the safety chains are damaged in any way, do not use the trailer until proper chains are installed. Substandard or damaged safety chains could allow the trailer to separate from the tow vehicle, resulting in equipment damage, personal injury, or death.

-
12. Route the wiring harness and breakaway brake cable in a manner that will prevent them from dragging. Be sure to provide enough slack for turning.

**SAFETY
INSTRUCTIONS**

Before towing the trailer, make sure:

1. The trailer lights and brakes are working properly. If the trailer's electrical equipment is not functioning properly, it may be due to incompatible or crossed wiring from the tow vehicle to the trailer.
 2. The trailer brakes apply when the brake pedal is depressed.
 3. The breakaway brake system activates and applies the brakes when the cable key is pulled from its socket.
-

9. OPERATION

9.1 OPERATING SAFETY

DANGER



Explosion/Fire Hazard
The Fuel Trailer is only intended for use with diesel fuel, gasoline or non-hazardous liquids, such as diesel exhaust fluid (DEF). DO NOT use this trailer with any other flammable liquid, such as kerosene. Transporting any other flammable or combustible liquid could result in a fire and explosion causing serious injury or death.





















WARNING









Read and Understand Manual
To prevent personal injury or even death, be sure you read and understand all of the instructions in this manual and other related OEM equipment manuals! The Fuel Trailer, if not used and maintained properly, can be dangerous to users unfamiliar with its operation. Do not allow filling, towing, refueling, maintaining, adjusting, or cleaning of this trailer until the user has read this manual and has developed a thorough understanding of the safety precautions and functions of the trailer.

DO NOT modify or use this trailer for any application other than which it was designed.

Trailers that are filled or operated improperly or by untrained personnel can be dangerous; exposing themselves and/or bystanders to possible serious injury or death.

1.  Make sure that anyone who will be operating the Fuel Trailer or working on or around the unit reads and understands all the operating, maintenance, and safety information in the operator's manual.
2.  Keep all bystanders, especially children, away from the equipment when filling or refueling.
3.  Keep working area clean and free of debris to prevent slipping or tripping.
4.  Keep hands, feet, hair, and clothing away from rotating parts on the machinery being refueled.
5.  Do not place hands, fingers, or arms between moving parts.
6.  Stay away from overhead power lines. Electrocutation can occur without direct contact.
7.  Use care when climbing on machinery to prevent slipping or falling.
8.  Know and follow applicable national, state, and local safety codes concerning safe handling of petroleum fuels.
9.    Gasoline is a highly flammable fuel. The improper use, handling, or storage of gasoline can be dangerous. Never fill a hot engine. **DO NOT** fill the engine's fuel tank near an open flame while smoking or while engine is running. **DO NOT** fill tank in an enclosed area with poor ventilation. Clean up any gasoline spills immediately.
10.     Before filling the trailer, make sure the engine of the tow vehicle is stopped, the transmission is placed in park, the key is removed, and the parking brake is set.
11.  Only store gasoline in containers with approved labels, as required by federal or state authorities. Never store gasoline in the front compartment of the trailer.
12. Manually control the nozzle valve throughout the filling process. Keep your face away from the nozzle or fuel tank opening.
13.  Avoid prolonged breathing of gasoline vapors.
14.  Keep gasoline away from your eyes and skin because it may cause irritation.
15.  Use gasoline only in open areas that get plenty of fresh air. Never use gasoline to wash your hands. Remove gasoline-soaked clothing immediately.
16.  Fill machinery's fuel tanks no more than 95 percent full to allow for expansion. Also, do not fill the IBC tank more than 95 percent full.

17.  Never dispose of any fuel by pouring it onto the ground or into a sewer, street drain, stream or other body of water, or putting it into the trash. These actions are environmentally harmful and may result in a fire, explosion, or soil, surface or groundwater contamination. Fines and criminal penalties may be associated with improper disposal.
18.  The muffler becomes very hot during operation and remains hot for a while after stopping the engine. Be careful not to touch the muffler while it is hot. Let the engine cool before storing it indoors.
19.  Exhaust gas contains poisonous carbon monoxide. Avoid inhalation of exhaust gas. Never run the engine in a closed garage or confined area. Open at least the driver's side door on the fuel trailer.
20.  Never exceed the weight limits of this trailer. Refer to "5.2 Specifications" on page 5-2 for maximum load ratings.
21.  An ignition source is always a concern in refueling. Gasoline is very explosive, especially the fumes. The most common source of electrostatic discharge (spark) is from the operator. The person refueling the equipment should always make a point of touching something away from possible fumes to ground and discharge themselves before refueling the gas engine.
22.  Use care when closing the manway cover. Do not place fingers between the cover and the rim.



9.2 FIRE EXTINGUISHER

A fire extinguisher may be supplied with the fuel trailer.

The extinguisher is mounted inside the right compartment door on the trailer. Do not install a fire extinguisher onto the IBC tank.

It is the operator's responsibility to follow the manufacturer's instructions to periodically check and maintain the fire extinguisher.

9.3 PRE-OPERATION CHECKS

1. The gasoline engine may not be shipped with oil. If necessary, add oil to the gasoline engine prior to starting for the first time.
2. Make sure the diesel fuel pump is properly primed before attempting to refuel any machinery. Refer to "2.6.3 Prime Gasoline Engine Fuel Pump (Diesel Only)" on page 2-2.
3. Review the OEM instructions provided with all equipment used on the fuel trailer for operating and safety precautions.
4. When towing the trailer with a truck, the 12 Volt electrical system is designed so the vehicle's charging system will charge the trailer's battery. Charging will only occur when the tow vehicle's engine/alternator is running and the wiring harness is properly configured.

This system will not recharge a depleted or dead battery; only help to maintain its current charge state. Use step 5 to make sure the tow vehicle is compatible with the fuel trailer.

5. Make sure the tow vehicle is equipped with a standard 7-way automotive wiring harness socket. If the tow vehicle is not equipped with a 7-way connector which is properly configured, the trailer battery will not be charged without custom wiring from the tow vehicle's alternator/charging system.
 - a. If equipped, check the 7-way socket on the tow vehicle using a Volt meter to make sure Pin 4 and Pin 1 are supplying 12 Volts of power. If any other pin has a 12 Volt supply, the battery will not be charged.

Note: To properly charge the battery, the tow vehicle's socket must be configured with Pin 4 (black) along with Pin 1 (white) connected to the 12 Volt supply.

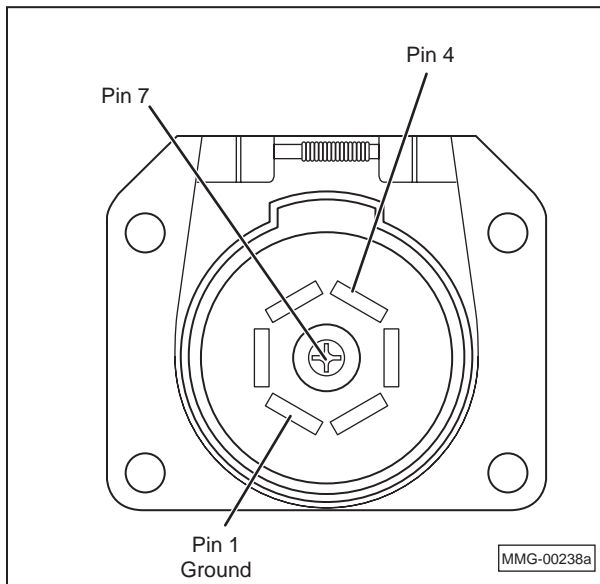

- b. If there is no voltage on any of the pins, check the fuse in the truck's fuse panel. The fuse for the charge line may not be installed or may be blown. Also check the tow charging relay that supplies power to the tow charging pin

Note: If the tow vehicle's wiring connections do not correspond to the fuel trailers wiring harness, the breakaway brake system battery will also not be charged during normal operation.

6. Always make sure the trailer lights and brakes are working properly before towing the trailer. Do not tow a trailer that is not operating properly.

7. The fuel trailer can be towed with a tractor; however, it is electrically wired for a 7-way automotive wiring harness application. An ag tractor will not properly operate the trailer's brake, battery charging system, or lights without special wiring modification. Do not tow the fuel trailer on public roads without proper brakes and lighting.

9.4 DEF AND DIESEL FUEL TANKS

9.4.1 Filling the Fuel Trailer with Diesel Fuel

1. Before filling the IBC tank, follow all the safety recommendations, such as attaching the fuel trailer to the tow vehicle, placing the fuel trailer on a level surface, blocking both sides of the wheels to prevent unexpected movement, etc.



2. Fill the trailer with fuel using 2" fill spout (1) or 3" camlock port (2). Use gauge (3) to prevent overfilling. Do not fill the tank more than 95% full [3125 L (825 gal.)].



9.4.2 Filling Machinery Using 12 Volt Electric Fuel Pump

WARNING



Do not use fuel tank as a work platform. Do not stand on fenders. Do not ride on trailer or allow others

to ride on trailer.

1. Position the fuel trailer near the machinery being refueled.
2. Extend the hose to easily reach the fill spout of the machinery being refueled.



MMG-00580

CAUTION

Once the pump is turned ON, the fuel hose is pressurized and will pump fuel. Do not squeeze the handle on the fuel nozzle until it is inside the fuel tank of the machinery being refueled.

3. Move the ON/OFF lever upward to the "ON" position to apply power to the pump.

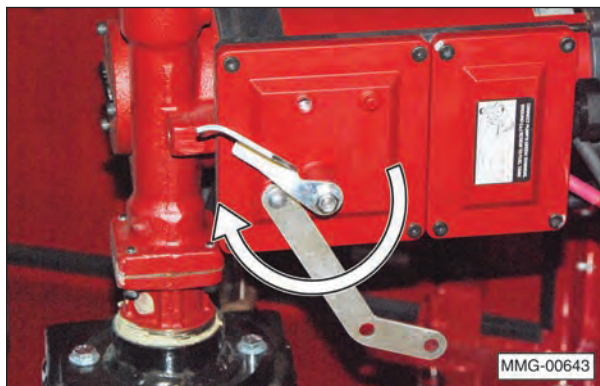

MMG-00643

Fuel Pump Lever in "ON" Position.

4. Refuel the machinery. Release the nozzle when the desired amount of fuel has been dispensed. Move the ON/OFF lever downward to the "OFF" position to turn off the pump.



MMG-00644

Fuel Pump Lever in "OFF" Position.

5. Remove the dispensing nozzle from the machinery being refueled and retract the hose onto the hose reel.

Note: If the hose is extended to its limit, it may not retract. Should this occur, grasp the reel and rotate it towards you until it clicks. The hose will then retract normally.



MMG-00597

9.4.3 Filling Machinery Using Gasoline Powered Fuel Pump

WARNING

 Do not use the fuel tank as a work platform. Do not stand on the fenders. Do not ride on the trailer or allow others to ride on the trailer.

This petroleum pump is a self-priming centrifugal pump and only requires priming prior to its initial start. The pump will retain sufficient liquid for self-priming thereafter.

To prime the pump:

- a. Remove the fill plug on top of the pump housing.
- b. Fill the pump housing with filtered diesel fuel.
- c. Replace the plug.

To fill the machinery:

1. Position the fuel trailer near the machinery being refueled.
2. Extend the hose to easily reach the fill spout of the machinery being refueled.



3. If using the optional gasoline engine, start the engine.



- a. Turn engine fuel lever (3) to the ON position.



- b. To start a cold engine, move choke lever (4) to the left (closed). In warm weather, start the engine with the choke in the middle position. To restart a hot engine, move the choke lever to the closed position.



- c. Move throttle lever (5) away from the SLOW position to the FAST position.



- d. Use engine pull cord (2) or electric start (1) and start the engine.



- e. If the choke lever is in the CHOKE position, gradually move it to the right (OPEN) position as the engine starts to run.



CAUTION

Once the pump is started, the fuel hose is pressurized and will pump fuel. Do not squeeze the handle on the fuel nozzle until it is inside the fuel tank of the machinery being refueled.

4. Place the fuel nozzle into the receiving tank and squeeze the handle to start fuel flow. When the tank is full, the nozzle will automatically shut off the flow.

Note: If an electronic fuel meter is attached to the hose, a specific amount of fuel can be added.

NOTICE

When filling machinery from the fuel trailer, never allow the pump to run dry. Operating the pump without fuel can cause damage to the pump and/or gasoline engine.

5. When fueling is complete, turn the gasoline engine off.
6. Remove the dispensing nozzle from the machinery being refueled and retract the hose onto the hose reel.



Shut off fuel
when not in use.

7. Place the engine's fuel lever in the OFF position before towing the fuel trailer on the open road.



8. Allow the engine to cool for at least 15 minutes, with both compartment doors open, before towing.

WARNING

 To prevent a fire, which could lead to personal injury or death, allow the engine to cool before closing the engine compartment doors. A hot engine and exhaust system could ignite various materials within the front compartment.

9.4.4 Filling the Trailer's DEF Tank

Review the section on DEF Solution in this manual before filling the DEF tank or servicing the machinery.

1. Fill the DEF tank using the fill port. The fluid level will be evident through the side of the white poly tank. Do not overfill the tank.



NOTICE

Observe the fluid level through the side of the white poly tank. Do not overfill the tank.

Note: Ensure breather on top of the tank is not blocked and is properly tightened.

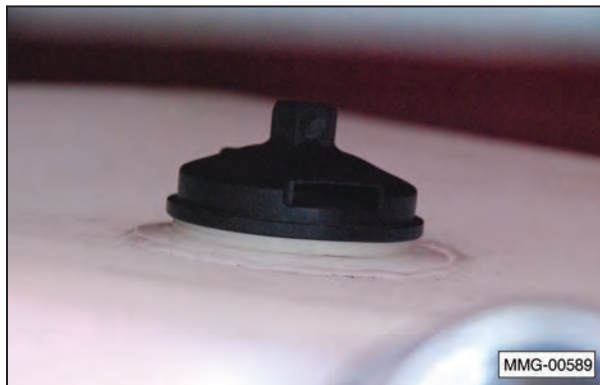

Note: To prevent contamination of the DEF fluid, keep the DEF nozzle and the fill port clean and free of dust and dirt.

9.4.5 Filling the DEF Tank on Machinery

The DEF transfer pump (1) is a 12 Volt DC, self-priming, positive-displacement vane pump.

Note: If the pump does not operate, make sure the in-line fuse is working.

SAFETY INSTRUCTIONS

This pump should only be used to pump DEF solution from the fuel trailer to the machinery being serviced. Do not pump any other type of fluid.

1. Ensure the power switch on the DEF pump is in the OFF position.

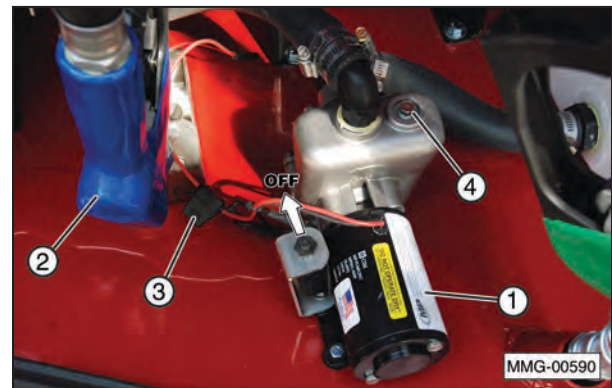

(1) DEF Pump. (2) DEF Nozzle. (3) Fuse - 20 Amp. (4) Fill Plug.

NOTICE

To avoid contaminating the DEF solution and possible nozzle malfunction, keep the nozzle clean. Always store the nozzle in the nozzle holder when not in use.

2. Extend the DEF hose to easily reach the fill opening of the machinery being serviced.



CAUTION

Once the pump is turned ON, the DEF hose is pressurized and will pump DEF solution. Do not squeeze the handle on the nozzle until it is inside the DEF tank of the machinery being serviced.

3. Turn the power switch to the ON position to start the DEF pump.



4. Fill the machine's DEF tank. Once the DEF tank is filled, turn the pump OFF. Do not run the pump any longer than necessary.

SAFETY INSTRUCTIONS

Even though nozzle (2) is equipped with an automatic shutoff, do not leave the nozzle unattended during filling. Be prepared to manually shut off flow at the nozzle, if necessary.

5. Replace the nozzle in its holder.



Note: If the hose is extended to its limit, it may not retract. Should this occur, grasp the reel and rotate it towards you until it clicks. The hose will then retract normally.



9.5 DEF SOLUTION

The information concerning DEF provided in this manual has been obtained from sources considered technically accurate and reliable. Review the safety information concerning potential product hazards. Since the actual product use is beyond our control, it is assumed that the user has been fully trained to meet any local, state, or federal regulations.

9.5.1 DEF Solution Safety Practices

SAFETY INSTRUCTIONS



Respiratory protection is not usually required. If significant spray or mist occurs, wear a NIOSH approved or equivalent dust respirator.



The use of gloves, impermeable to the specific material handled, is advised to prevent skin contact, possible irritation, or absorption.



Approved eye protection to safeguard against potential eye contact, irritation, or injury is recommended. Depending on the conditions of use, a face shield may be necessary.



A source of clean water should be available in the work area for flushing eyes and skin. Impervious clothing should be worn, as needed.



DO NOT operate the pump at voltages which exceed the 12 Volt rating indicated on the name plate. Operating the pump with more than 12 Volts will cause the motor to overheat.

9.5.2 First Aid Measures

Eye: If irritation or redness develops, move away from exposure and into fresh air. Flush eyes with clean water immediately for at least 15 minutes. If symptoms persist, seek medical attention.

Skin: Remove contaminated shoes and clothing and cleanse affected area(s) thoroughly by washing with mild soap and water. If irritation or redness develops and persists, seek medical attention.

Inhalation (Breathing): If respiratory conditions develop, move away from source of exposure and into fresh air. If symptoms persist, seek medical attention. If victim is not breathing, clear airway and immediately begin artificial respiration. If breathing difficulties develop, oxygen should be administered by qualified personnel. Seek immediate medical attention.

Ingestion (Swallowing): First aid is not normally required; however, if swallowed and symptoms develop, seek medical attention.

9.5.3 General Information

- DEF has not been shown to be harmful to humans or animals.
- DEF is not explosive, does not burn, and will not aid in combustion.
- DEF is non-toxic. If you get it on your skin or clothes, rinse with plenty of water.
- DEF is a colorless liquid. However, it is best to avoid spilling on clothing or vehicle upholstery as it may leave a stain.

NOTICE

DEF is very corrosive to certain types of material. Care should be taken when filling the trailer or the machinery.

9.5.4 Storage

1. Keep DEF containers tightly closed.
2. To avoid solidification, do not store DEF at temperatures below 23°F (-5°C). Solidified DEF, which has been warmed up carefully at temperatures not exceeding 86°F (30°C), will not be impaired in quality and can be used as soon as the warmed up solution is free from solids. Frozen DEF can be thawed and used without concerns of product degradation; however, damage to the container or equipment will likely occur.
3. Store only in approved containers.
4. Protect containers against physical damage.
5. In order to prevent decomposition of the urea, as well as the evaporation of water in the case of vented containers, prolonged transportation or storing above 77°F should be avoided. (See table below).

Constant Ambient Storage Temperature (°F)	Minimum Shelf Life (Months)
≤50°F	36
≤77°F*	18
≤86°F	12
≤95°F	6
>95°F	**

* To prevent decomposition of the DEF solution, prolonged transportation or storage above 77°F should be avoided.
 ** Significant loss of shelf life. Check every batch before use.
 Source: ISO 22241-3:2008(E)

9.5.5 Using DEF

1. Only fill the DEF tank with ISO certified DEF that has been delivered in dedicated, sealed DEF packages.
2. Wear appropriate protective clothing and equipment, such as safety glasses, gloves, etc. while pumping DEF.
3. Wash thoroughly after handling DEF.
4. Never add DEF into the diesel fuel tank.
5. Never add diesel fuel into the DEF tank.
6. Avoid contact with DEF on eyes, skin, and clothing.
7. If spilled, rinse the area with water.
8. Do not use DEF that has been diluted with water or other substances.

9.5.6 DEF Disposal

For proper disposal of waste DEF, as a non-hazardous liquid waste, it should be solidified with stabilizing agents such as sand, fly ash, or clay absorbent, so that no free liquid remains before disposal in an industrial waste landfill.

10. STORAGE

10.1 GENERAL INFORMATION

When the Fuel Trailer will not be used for an extended period of time, perform a complete inspection. Replace or repair any worn or damaged components to prevent unnecessary downtime at the beginning of the next season.

10.2 PLACING IN STORAGE

CAUTION



Store the trailer in an area away from human activity. To prevent the possibility of serious injury, do not permit children to play on or around the stored equipment.

1. Remove all fuel from the Fuel Trailer.
2. Place the gasoline engine fuel valve in the OFF position.
3. Drain the gasoline engine fuel tank and carburetor for seasonal or long-term storage. If this is not possible, add a fuel additive to the gas tank.
4. Thoroughly wash the equipment with a pressure washer or water hose to remove all dirt, mud, or debris.
5. Remove any entangled material from the underside of the trailer.
6. Check the condition of the fuel pump and DEF pump. Replace or adjust, as required.
7. Touch up paint nicks and scratches to prevent rusting.
8. If the engine has been running, allow it to cool for at least half an hour before closing the compartment doors.
9. Remove the engine's ignition key and store in a secure place.
10. Remove the battery and store it in a cool, dry area on wooden blocks or a wooden pallet. Charge it monthly to maintain an adequate charge. This will help to extend the service life of the battery.
11. It is best to store the equipment inside. If possible, avoid any area with high humidity. Humidity promotes rust and corrosion.

10.3 REMOVING FROM STORAGE

When removing the equipment from storage, follow this procedure:

1. Install and connect the battery.
2. Add new fuel to the gasoline engine's fuel tank.
3. Review and follow the Daily Pre-Operation Checklist.
4. Review and follow the service checks in the Services section.

IMPORTANT

If the equipment has been stored for more than 12 months, warm the engine by running it for two to three minutes and then drain the oil. Change the oil while the oil is warm to remove any condensation. Refer to "11.5.3 Change Engine Oil" on page 11-4.

10.4 WINTERIZING THE DEF SYSTEM

Since the majority of the DEF solution is water, freezing of this solution can cause damage to the components of the DEF system. It is recommended that the solution be removed from the DEF tank and stored in a DEF compatible container.

NOTICE

Do not allow DEF fluid to freeze in the tank. Since DEF solution is mostly water, freezing and expansion of the solution will cause damage to the tank and the pump. The warranty is void if freezing occurs.









11. MAINTENANCE





11.1 SAFETY

WARNING

Do not lift the tank when it is loaded with product. It could rupture or fall, which could lead to personal injury or death. Empty the tank before lifting.







11.1.1 General Safety

1. Good maintenance is your responsibility. Poor maintenance is an invitation for trouble.
2. Follow good shop practices. Keep service area clean and dry. Be sure electrical outlets and tools are properly grounded. Use adequate light.
3.  Ensure proper ventilation. Never operate the engine in a closed building. The exhaust fumes may cause asphyxiation.
4.  Before working on this equipment, shut off the engine and remove the ignition keys.
5.  Never work under equipment unless it is securely blocked.
6.  Always use personal protection devices, such as eye, hand, and hearing protectors, when performing any service or maintenance.
7.  Do not alter or modify the fuel tank or trailer in any manner. Repairs should only be accomplished by a certified dealer familiar with this type of equipment. This fuel tank is not designed for stacking or to be stacked.
8.  Where replacement parts are necessary for periodic maintenance and servicing, genuine factory replacement parts must be used to restore your equipment to the original specifications. The manufacturer will not be responsible for injuries or damages caused by use of unapproved parts and/or accessories.
9.   A fire extinguisher and first aid kit should be readily accessible while performing maintenance on this equipment.

10.  Periodically tighten all bolts, nuts, and screws and ensure all cotter pins are properly installed to ensure the unit is in safe condition.
11.  When completing a maintenance or service function, make sure all safety shields and devices are installed before placing the unit in service.
12.  Do not attach any lifting device directly to the filled fuel tank. The fuel tank can only be lifted if it is empty. Lifting a full fuel tank will result in damage to the tank and possible personal injury.
13.  Do not raise the trailer off the ground in any way when the fuel tank is loaded with fuel. If the trailer must be raised to change a tire or for axle maintenance, the tank should be empty.

SAFETY INSTRUCTIONS

The following safety instructions are provided to help prevent injury or limit equipment damage.

-  DO NOT operate the engine with the fuel tank cap loose or missing.
-  DO NOT clean engine air filter with gasoline or other types of low flash point solvents.
-  DO NOT operate the unit without a functional exhaust system. Prolonged exposure to sound levels in excess of 85 dBA can cause permanent hearing loss. Wear hearing protection when working around a running engine.
-  Keep hands, feet, and loose clothing away from moving parts on the engine.
-  Keep area around exhaust free of debris to reduce the chance of an accidental fire.
-  Do not operate the gas engine if any of the following conditions exist during operation:
 1. Noticeable change in engine speed.
 2. Sparking occurs.
 3. Engine misfires or there is excessive engine vibration.

11.2 WHEEL BEARINGS

Each axle is equipped with a grease zerk under the center dust cap of the wheel. Add grease sparingly to the wheel bearings, using only wheel bearing grease. The wheel bearings should be repacked annually. Check for excessive end play and tighten, if necessary.

IMPORTANT

Over-greasing wheel bearings can cause them to overheat, resulting in damage and/or failure.



CAUTION





 Do not raise the trailer off the ground with fuel in the tank. Always make sure the tank is empty before performing any maintenance.

11.3 BATTERY

Inspect the battery at least once every six months and before using the Fuel Trailer at the beginning of the season. Always follow the safety instructions when servicing a battery.



11.3.1 Battery Safety

1.  Keep all sparks and flames away from batteries, as gas given off by electrolyte is explosive.
2.  Avoid contact with battery electrolyte: wash off any spilled electrolyte immediately because battery acid can cause severe chemical burns.
3.  Wear safety glasses when working near batteries.
4. Do not tip batteries more than 45 degrees, to avoid electrolyte loss.
5.  To avoid injury from a spark or short circuit, disconnect the battery ground cable before servicing any part of the electrical system. Never short circuit the battery; it may explode.
6.  Protect battery terminals, battery-charger terminals, and cables against accidental contact, which can cause sparks, explosions, or component damage.
7. Never attempt to jump-start a frozen battery.

11.3.2 Battery Replacement and Maintenance Tips

- Check the batteries at least every six months for low voltage, leakage, etc.
- Always use the correct size and type of battery. Replace old batteries with a new 12 Volt deep cycle battery.
- Do not install the battery cable to the wrong terminal. Make sure the RED cable is connected to the + (plus) terminal and the BLACK cable is connected to the – (minus) terminal.
- Remove the batteries from the fuel trailer if not expected to be in use for several months.
- Use recommended practices when recharging a dead battery.
- Remove any corrosion from the battery posts using a wire brush terminal cleaner. Corrosion can also be removed using a baking soda paste and water to neutralize and remove the acid from the battery terminals.
- Dispose of old batteries properly.

11.3.3 Battery Maintenance

1. Make sure the top of the battery box is installed and in good condition (not cracked, cut, or damaged).
2. The battery is not charged when the engine is operating. If the battery will not charge using an external charger, check the fuse. Replace the fuse if necessary.

11.4 FUSES

The fuel trailer may use either of two types of blade fuses.

Older fuel trailers have regular ATO/ATC fuses located within a control box inside the battery box.



MMG-00600

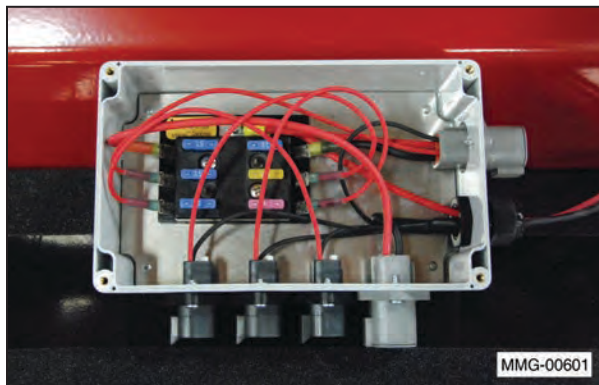

MMG-00601

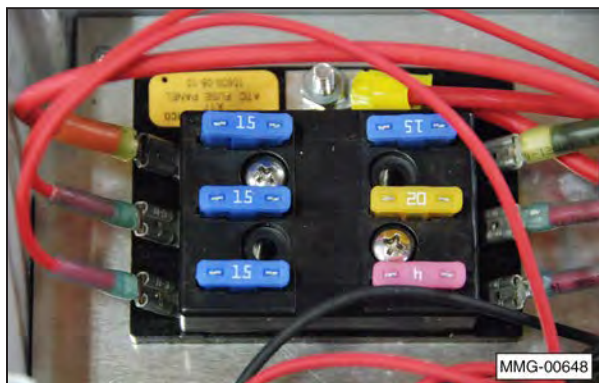

MMG-00648

Newer fuel trailers have harness mounted fuse holders that accept mini APM/ATM fuses.

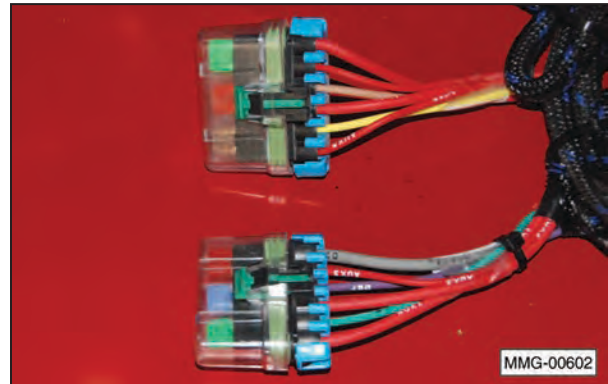

MMG-00602

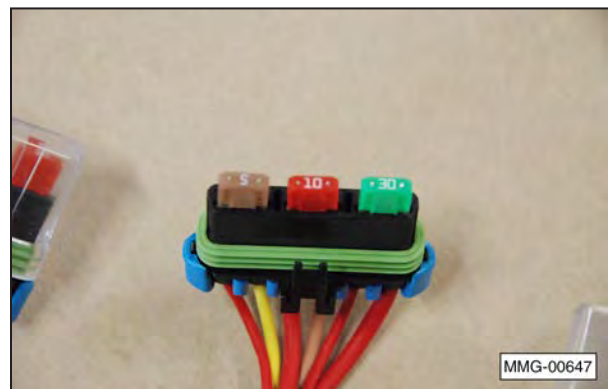

MMG-00647

The DEF pump has an in-line fuse holder with a 20 Amp fuse.



MMG-00603

11.5 GASOLINE ENGINE (OPTIONAL)

Gasoline engines are not typically shipped with oil. Check and add oil to engine prior to operating, as needed.

For any questions concerning the gasoline engine not provided in this manual, refer to the OEM manual that was provided with the fuel trailer.

For contact information on the manufacturer, refer to the OEM Literature section in this manual.

11.5.1 Approved Fuel

Use a regular unleaded automotive gasoline for all operating conditions. The fuel tank capacity is approximately 1.0 gallons.

The fuel trailer engines are designed for good performance and efficient operation using gasoline without ethanol.

NOTICE

E85 is an alternative fuel and Meridian's equipment is not designed for this type of fuel. E85 is not gasoline. It is made by combining 85% ethanol with 15% gasoline. The fuel trailer engine is not currently certified or designed to run on E85 or any other alternative fuel.

Always refer to the OEM Owner's manual for a list of recommended fuel and the current approved additives.

11.5.2 Engine Oil

Use a typical SAE 10W-30 or 10W-40 multi-viscosity motor oil for normal operating conditions. Consult your engine manual for the recommended oil in cold temperatures. The crankcase capacity is 0.6 liters (0.63 US qt.).

11.5.3 Change Engine Oil

1. Review the Operator's Manual for the engine.
2. Allow the engine to cool slightly before changing the oil. Draining works best when the oil is warm.

CAUTION



BURN HAZARD
Hot engine oil can burn skin.

3. Be sure the engine key switch is in the OFF position and the fuel valve is turned OFF.
4. Remove the drain plug and allow the oil to drain for 10 minutes.



5. Reinstall the drain plug and tighten.
6. Dispose of the oil in an approved container. Follow industrial disposal regulations. Fill the engine case to the full mark on the dipstick with SAE 10W-30 oil for general usage. If the engine is operated in more extreme conditions, refer to the OEM manual for oil recommendations.



7. Run the engine for one minute and recheck the oil level. Add oil, as needed.

11.5.4 Air Filter Inspection

A dirty air filter will restrict air flow to the carburetor, reducing engine performance. If you operate the engine in very dusty areas, clean the air filter more often than specified in the maintenance schedule.

1. Remove the air cleaner cover and inspect the filter and foam cover weekly.



2. Remove any debris from the foam cover. Thoroughly clean or replace the foam cover every three months or 50 hours of operation (clean it more frequently when used in dusty conditions).
3. Clean or replace dirty filter elements. Always replace damaged filter elements.



NOTICE

Operating the engine without an air filter, or with a damaged air filter, will allow dirt to enter the engine, causing rapid engine wear. This type of damage is not covered by any warranty.

4. Replace the cover. Make sure the washer is in place.



11.6 ENGINE CIRCUIT PROTECTION

The circuit protector protects the battery charging circuit. A short circuit, or a battery connected with reverse polarity, will trip the circuit breaker.

The indicator inside the circuit protector will pop out to show that the circuit protector has switched off. If this occurs, determine the cause of the problem and correct it before resetting the circuit protector.

Push the circuit protector button to reset.



11.7 CHANGING DIESEL FUEL FILTER

NOTICE

Fuel will be in the filter and the line. Place a catch basin under the filter to contain the excess fuel before removing the filter.

1. Make sure the fuel pump is off before removing the filter.
2. Using a filter wrench, loosen and remove the filter.



3. Install the new filter.
4. Properly dispose of the used filter and the excess fuel.

11.8 ENGINE TO PUMP CONNECTION (GASOLINE ENGINE OPTION ONLY)

Check the coupling between the pump and engine annually.



11.9 TRAILER BREAKAWAY SYSTEM



11.9.1 Testing the Battery

1. Disconnect the trailer plug from the tow vehicle; otherwise, you are testing the tow vehicle's battery.
2. Press the green TEST button on the control box located inside the frame of the trailer. The green indicator light should illuminate if the battery is fully charged. If the yellow or red indicator lights illuminate, the unit's battery should be charged before towing the trailer.

IMPORTANT

If the battery is weak or dead (red indicator, even after charging), as indicated by the indicator light, the battery must be replaced.

3. Plug the trailer into the tow vehicle. The yellow "Charging" light should be ON.
4. Test the system by pulling the pin out of the breakaway switch. The battery will activate the brakes. (**Note:** Do not use this kit as a parking brake). The battery should be charged and tested prior to each trailer outing.



11.9.2 Charging the Battery

The battery in the breakaway system is rechargeable. If the battery will not hold a charge, replace the battery.

11.9.3 Replacing the Battery

The battery in the breakaway system is replaceable. If the battery will not hold a charge, replace the battery. Contact the OEM supplier for a replacement battery.



11.9.4 Testing the System

1. Test the system by pulling the pin out of the breakaway switch. The battery will activate the brakes.
2. Gently pull the trailer on a concrete or asphalt surface with the tow vehicle.
3. The trailer should not move.

11.10 WHEEL BOLT TORQUE REQUIREMENTS



1. Initially check the wheel bolt torque at 10, 25, and 50 miles and after each wheel removal.

Note: Torque wrenches are the best method to ensure the proper amount of torque is being applied to a wheel nut.

CAUTION



EXPLOSIVE FORCE HAZARD

To prevent injury due to possible dangerous separation of wheels from the axle, the wheel nuts must be maintained at the proper torque levels. Properly maintained wheel nuts prevent loose wheels and broken studs.

2. Tighten the wheel nuts in three stages.
 - First stage: 25 foot pounds.
 - Second stage: 60 foot pounds.
 - Third stage: 120 foot pounds.
3. Tighten the wheel nuts in a clockwise, cross-axle alternating pattern.

11.11 AXLE BOLTS, TRAILER HITCH BOLTS, AND TANK HOLD-DOWN BOLTS

Check the torque on the axle to frame bolts, tank hold-down bolts, and trailer hitch bolts at least once per year.



CAUTION



Do not raise the trailer off the ground with fuel in the tank. Always make sure the tank is empty before performing any maintenance.

11.12 TANK REPLACEMENT

1. Make sure rubber strips between the tank and trailer are properly located and not damaged.

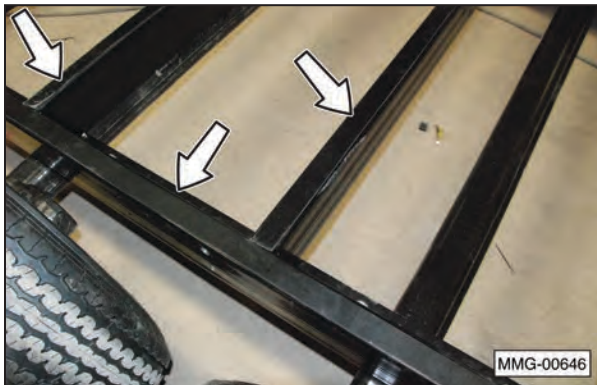

2. Make sure the mounting bolts are properly secured and not damaged. Replacement bolts should be 5/8-11 x 3 inches long with a Grade 8 rating. Refer to "5.3.1 Bolt Torque Values" on page 5-3 for the proper tightening torque.

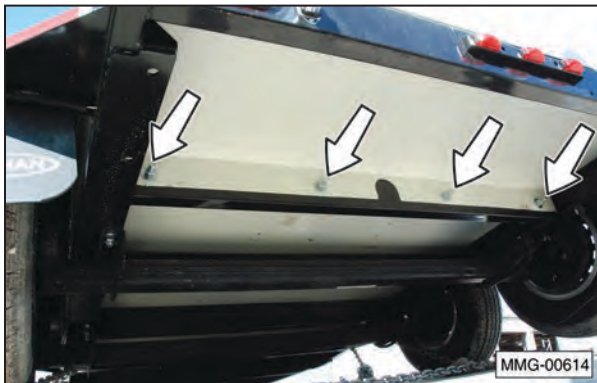

11.13 REAR MOUNTED TOOL BOX

1. Periodically open the drain valve on the air compressor to release any trapped moisture.



2. Check the torque on the tool box-to-tank bolts at least once per year.



11.14 OPTIONAL COMPRESSOR

1. Maintain compressor oil level on or slightly above the red indicator circle.

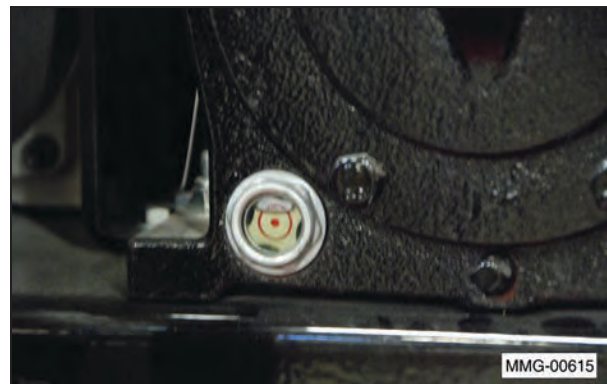

12. SERVICE

12.1 SERVICE RECORD CHART

The chart on the following pages should be copied and filled out as maintenance is performed on the equipment. Refer to the Lubrication, Maintenance, and Service sections for additional instructions.

Date																		
Serviced by																		
8 Hours or Daily																		
Check Engine Fluid Levels.																		
Test Breakaway Brake System. Refer to "11.9 Trailer Breakaway System" on page 11-6.																		
Inspect Tires for Wear and Damage.																		
Inspect Taillights and Running Lights.																		
Inspect 7-pin Connector Plug.																		
50 Hours or Weekly																		
Clean Engine Air Intake Filter. Refer to "" on page 11-4.																		
Check Tire Pressure. (Found on sidewall of tire).																		
200 Hours or Semiannual																		
Adjust Brakes per OEM manual.																		
Inspect Brake Magnets per OEM manual.																		
Make sure the battery box is securely holding the battery onto the frame, check the electrolyte levels in the cells, and clean terminals to remove any dirt or corrosion.																		
Check and/or Replace Diesel Fuel Filter. Refer to "11.7 Changing Diesel Fuel Filter" on page 11-6.																		
400 Hours or Annually																		
Change Engine Oil.																		
Check Wheel Bolt Torque. Refer to "11.10 Wheel Bolt Torque Requirements" on page 11-7.																		
Check Frame Hold-Downs. Refer to "11.12 Tank Replacement" on page 11-8.																		
Check Bolt-On Hitch Tongue Bolts. Refer to "11.11 Axle Bolts, Trailer Hitch Bolts, and Tank Hold-Down Bolts" on page 11-7.																		
Inspect Brake Lining Wear, Brake Cylinder, and Brake Wiring.																		
Repack Wheel Bearings and Check Hub for Wear. Refer to "11.2 Wheel Bearings" on page 11-2.																		
Inspect Axle Grease Seal.																		
Inspect Diesel Fuel Pump. Refer to "14.2 Diesel Fuel Pump" on page 14-2.																		

400 Hours or Annually (continued)																				
Inspect DEF Solution Pump. Refer to “14.1 Engine and DEF Pump” on page 14-1.																				
Inspect all electrical wiring connections for looseness or corrosion. Tighten and/or seal, as necessary.																				
Inspect all fittings, closures, structural components, vents, valves, pumps, lids, and gaskets for defects. Visually inspect the tank internally and externally for dents, defective welds, corrosion, and loss of protective coating.																				
Thoroughly Clean Equipment.																				
60 Months																				
Leak test in accordance with Transport Canada CGSB-43.146-2002 standards.																				

12.2 SERVICE CHECKS

12.2.1 Daily (8 Hours)

WARNING

 **Gasoline is a highly combustible fuel. Improper use, handling, or storage of gasoline can be dangerous. Never touch or fill a hot engine. DO NOT fill the engine’s fuel tank near an open flame while smoking or while the engine is running. DO NOT fill the tank in an enclosed area with poor ventilation. Wipe up spills immediately.**

1. Check engine oil and fuel levels and fill, as needed. Refer to “14.1 Engine and DEF Pump” on page 14-1.



2. Test the trailer breakaway brake system. Refer to “11.9 Trailer Breakaway System” on page 11-6.
3. Inspect the tires for wear and damage.

4. Inspect the taillights and running lights to make sure they are working properly.
5. Inspect the 7-pin wiring harness connector for damage.

12.2.2 Weekly (50 Hours)

1. Clean or replace the foam filter element. Replace the paper air filter, as required.



2. Check the tire pressure. Inflate the tires to the recommended pressure stated on the tire.
3. Check and/or replace the diesel fuel filter. Refer to “11.7 Changing Diesel Fuel Filter” on page 11-6.

12.2.3 Semiannual (200 Hours)

1. Adjust the brakes per the OEM manual.
2. Inspect the brake magnets per the OEM manual.
3. Make sure the battery box is securely holding the battery onto the frame. Check the electrolyte levels in the cells, and clean the terminals to remove any dirt or corrosion.
4. Check and/or replace the diesel fuel filter. Refer to "11.7 Changing Diesel Fuel Filter" on page 11-6.

12.2.4 Annually (400 Hours)

1. Check the wheel bolt torque. Refer to "11.10 Wheel Bolt Torque Requirements" on page 11-7.
2. Repack the wheel bearings and check for excessive end play in the bearings. Refer to "14.3 Axle" on page 14-2.
3. Check the frame and tank hold-down bolts. Refer to "11.12 Tank Replacement" on page 11-8.
4. Check the trailer hitch tongue bolts. Refer to "11.11 Axle Bolts, Trailer Hitch Bolts, and Tank Hold-Down Bolts" on page 11-7.
5. Thoroughly clean the fuel trailer.
6. Check the tires for wear, and replace if needed.
7. Check the taillights to make sure they are working properly.



8. Inspect all fittings, closures, structural components, vents, valves, pumps, lids, and gaskets for defects. Visually inspect the tank internally and externally for dents, defective welds, corrosion, and loss of protective coating. Check bolt torque on the manway to tank bolts.

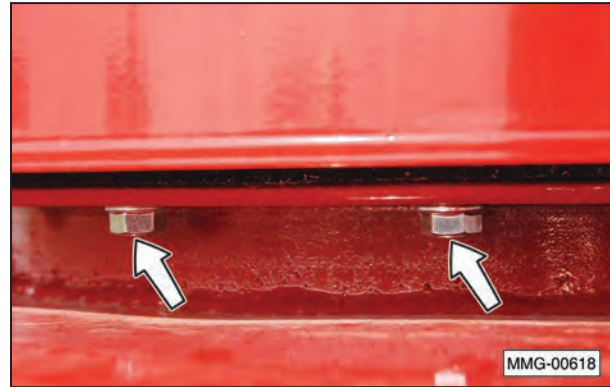

9. Inspect the DEF pump and the gasoline engine. Refer to "14.1 Engine and DEF Pump" on page 14-1.
10. Check the fender mounting bolts.





12.2.5 60 Months

All IBC's over 450 litres must have a leak test and inspection conducted by a registered and certified facility in accordance with CGSB-43.146-2002 Appendix C within 60 months of the original date of manufacture, and every 60 months or less thereafter.

IMPORTANT NOTICE

The tank owner/user is fully responsible for the testing and recertification of the tank.

A list of testing facilities holding a "Certificate of Registration to Leak Test and Inspect IBC's" is available from Transport Canada at:

<http://wwwapps.tc.gc.ca/saf-sec-sur/3/fdr-rici/ibc/ibcleak.aspx>

The test must show no defects that could render the tank unsafe for transporting dangerous goods. A tank having defects must be repaired, re-inspected, and leak tested. A tank that fails the test and is not repaired must have any specification marks removed or obliterated and the tank identified as unfit for dangerous goods service.

After the tank passes the test and inspection, obtain a copy of the leak test record from the testing facility and retain it until the next required leak test and inspection.

12.3 AXLES

12.3.1 First 200 Miles

1. Adjust brakes. Refer to OEM manual for procedure.

12.3.2 3,000 Miles or 3 Months

1. Adjust brakes. Refer to OEM manual for procedure.
2. Check torque on wheel nuts. Refer to the section in this manual.
3. Inspect tires for wear. Refer to OEM manual for procedure.

12.3.3 6,000 Miles or 6 Months

1. Inspect brake magnets for wear. Refer to OEM manual for procedure.
2. Inspect suspension parts for wear. Refer to OEM manual for procedure.

12.3.4 12,000 Miles or 12 Months

1. Inspect brake lining wear, check brake cylinder for leaks, and inspect brake wiring for damage. Refer to OEM manual for procedure.
2. Grease the wheel bearings and check the hub for wear. Refer to OEM manual for procedure.
3. Inspect grease seal for leakage. Refer to OEM manual for procedure.

12.4 TIRES

Check the tires for normal and/or abnormal tire wear. Replace tires that are damaged or worn beyond normal tread life. Refer to the axle OEM manual for a Tire Wear Diagnostic Chart.

Replace the tires with Meridian part number 18131 or an equivalent tire:
 3T235/80R16
 TR643
 Load Range E
 For Trailer Service Only

12.5 WELDING REPAIRS



Repair welding must be done with care and with procedures that may be beyond the capabilities of the ordinary welder.

Before performing any type of welding repair to the fuel trailer, contact Meridian for approval.

WARNING



Personal Injury Hazard

Repairs or modifications to the trailer, trailer tongue, or trailer hitch can result in serious injury or death should these repairs fail.

IMPORTANT NOTICE

Anyone performing a welding repair should be certified in accordance to the American Welding Society (AWS) standards.

WARNING



Do not weld on or around the fuel tank. Fuel vapors are highly explosive and will cause damage or personal injury if ignited. Before any welding is done on the fuel trailer, contact Meridian for further instructions.

12.6 DEF TANK DRAIN PLUG

Ensure the DEF tank drain plug is not leaking. In the event the plug has to be removed, use a DEF compatible thread sealant on the threads when replacing it.

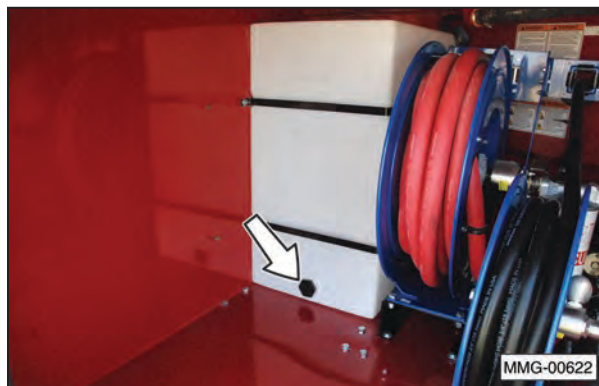

12.7 DOOR LIGHT SWITCH

The lights on both doors are activated by plunger switches. If the lights do not illuminate when the door is opened, check the switches, bulbs, wiring connections, and/or fuse.

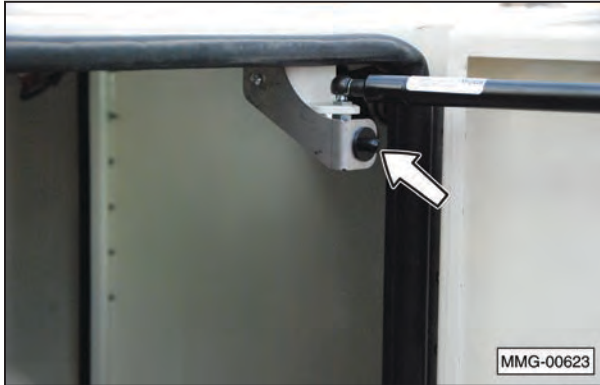

13. OPTIONS

13.1 REAR MOUNTED TOOL BOX



Optional configurations of the contents vary depending on the model and optional equipment that has been purchased.

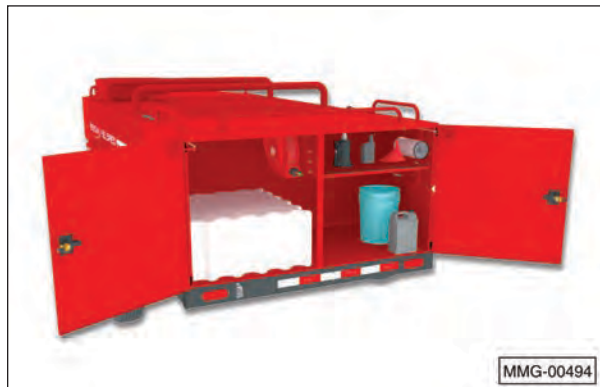

Open tool box for storage of customer related items.

NOTICE

This unit is not shipped with gasoline in the fuel tank or oil in the engine's sump. Fill tank with fresh gasoline before starting. Use 10W30 oil in the engine's sump.

CAUTION

Follow all safety instructions in the OEM manuals pertaining to use of the electrical, air pressure, and welding systems. If the OEM Operator Manual(s) are not available, obtain a copy before using this equipment.

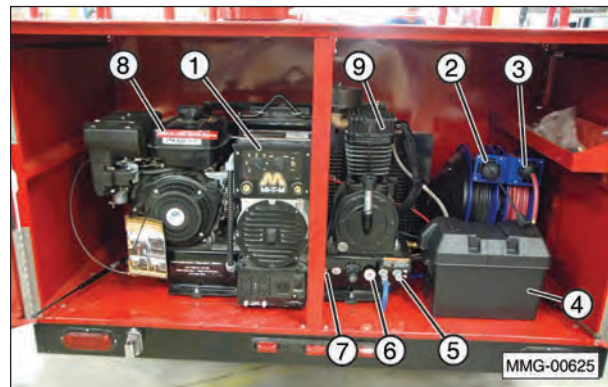

Optional 3-in-1 Air compressor/welder/generator. (1) Generator/welder. (2) Electrical power cord. (3) Air hose. (4) 12 Volt battery. (5) Air hose outlet. (6) Air pressure gauge. (7) Air tank pressure release valve. (8) Gasoline engine. (9) Air compressor.



(10) 125/250 Volt electrical outlet. (11) Four 110 Volt 20 Amp outlets. (12) Circuit breaker reset.

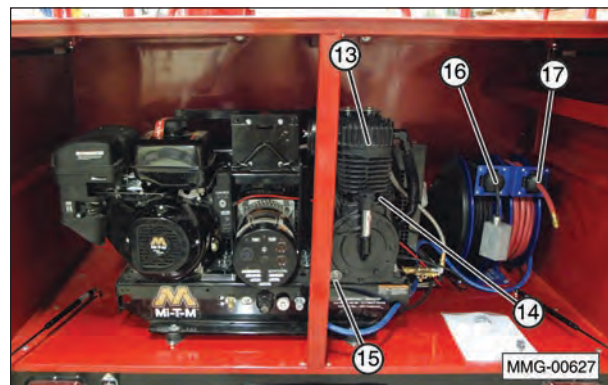

(13) Optional 2-in-1 Air compressor/generator. (14) Oil fill port. (15) Oil level indicator. (16) 110 Volt electrical cord. (17) Air hose.

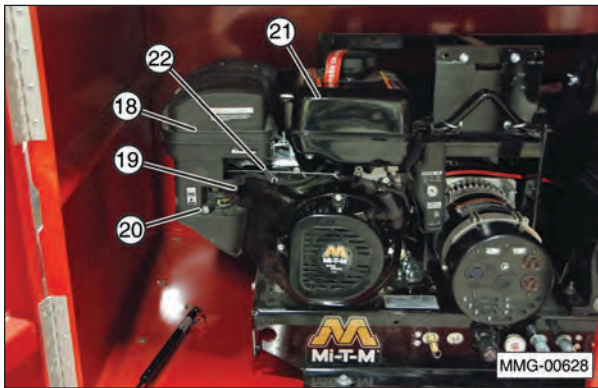

(25) Air cleaner. (26) Choke lever (open to the left and closed to the right, facing unit).
(27) Fuel shut off lever (open to the right and closed to the left, facing unit). (28) Gasoline tank. (29) Automatically controlled throttle lever.

14. OEM LITERATURE

OEM literature can be stored in the document storage tube located in the nose of the front compartment.



14.1 GASOLINE ENGINE

For any questions concerning the gasoline engine, diesel fuel pump, or DEF solution pump, refer to the OEM manual that was provided with the fuel trailer.

JD JIANGDONG

JF120N • JF168N • JF200N



Owner's Manual

14.2 DEF PUMP

Additional information can be obtained from:
MP Pumps
34800 Bennett
Fraser, MI 48026-1686

Phone: (586) 293-8240
(800)-563-8006
Fax: (586)-293-8469

www.mppumps.com



FRX 75-SP
3/4" x 3/4" Self Priming Centrifugal Pump

Model FRX 75-SP is a high performance self-priming 316 stainless steel centrifugal pump. The pump is ideal for marine, industrial, agricultural or commercial applications where suction lift is required.

The FRX 75-SP model features all 316 stainless steel components for superior corrosion resistance when pumping chemical compounds. A carbon / ceramic / Viton bellows shaft seal is standard. Ports are 3/4" NPT with a 1/8" NPT fill port. The FRX 75-SP model is capable of 12 foot suction lift (3450 rpm). Marine ignition protected motors (ISO 8846) available.

SPECIFICATIONS:

Suction and Discharge	... 3/4" NPT x 3/4" NPT
Materials of Construction	316 stainless steel
Flow Up to 21 GPM
Head Feet Up to 23'
Impeller 316 stainless steel semi-open
Motor ISO 8846 motor available
Drive Options Close coupled 115V AC
 Close coupled 12V DC
 Close coupled 230V AC
 Close coupled 24V DC
Seal Special seals upon request
 Standard - carbon / ceramic / Viton



Application:

- Agricultural
- Commercial
- Industrial
- Marine
- OEM

Patent #:

- US PATENT 8,202,048 B2

14.3 DIESEL FUEL PUMP

14.3.1 Electric Diesel Fuel Pump

Fill-Rite Electric Fuel Pumps
Tuthill Corporation
8825 Aviation Drive
Ft. Wayne, IN 46809

Toll Free: 800-634-2695

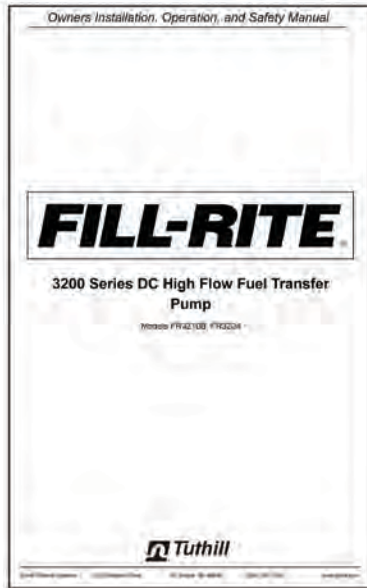

14.3.2 Gasoline Diesel Fuel Pump

Flow Max Diesel Fuel Pumps
MP Pumps, Inc.
34800 Bennett
Fraser, MI, 48026-1686

Phone: 586-293-8240
Toll Free: 800-563-8006
Fax: 586-293-8469

PETROLEUM SELF-PRIMING CENTRIFUGAL PUMPS

INSTRUCTION BULLETIN

Read this bulletin in full before installing, operating or servicing this pump. If any of the warnings of this bulletin are ignored serious injury or death could occur.

WARNING!

This pump was designed to handle volatile and flammable fluids. To reduce the risk of fire or explosion keep pump in well ventilated area free of explosive atmosphere. Do not smoke where the fuel is being handled, also keep away from any sparks or open flame. Do not operate pump with either the suction or discharge valves fully closed as this will over heat the pump. If pump becomes overheated allow to cool before next use.

Do not operate the pump in a manner that it was not intended to be used.	Do not continue to operate the pumping system when a known leak exists or the system starts to smoke.
Do not install a piping system that does not allow for any flex due to expansion from heat generated by the pumping system.	Do not continue to operate the pumping system when unusual noise or vibration occurs.
Do not allow severe temperature changes to occur in a short time period within the pumping system.	Do not perform service or maintenance when the pumping system is pressurized or hot.
Drain pump completely before switching fuel type that is to be pumped.	Do not mount pump in conditions that high piping loads exist on the pump flanges.

MODELS:

PO	Biodiesel, Diesel and Fuel Oil.
PG	Gasoline, Kerosene, Avgas Jet A and JP 8 Fuel.
PE	Ethanol and E-85.





FORM 3074-A (2/08)
PRINTED IN THE U.S.A.

14.4 GENERATOR/WELDER/COMPRESSOR



14.5 AXLE

For any questions concerning the Axis Products axle, refer to the OEM manual that was provided with the fuel trailer. An Owner's Manual and parts listing is provided with the fuel trailer.

Additional information can be obtained from:
Axis Products, Inc.
3403 Reedy Drive
Elkhart, IN 46514
Phone: (574) 266-8282

15. TROUBLESHOOTING

15.1 TROUBLESHOOTING CHART

PROBLEM	CAUSE	SOLUTION
Gasoline engine will not start.	No fuel.	Fill the fuel tank.
	Low engine oil.	Fill the crankcase with oil.
	Cold engine.	Open choke.
	Ignition key switch off.	Turn ignition key switch on.
	Battery dead.	Recharge or replace battery.
	Engine problem.	Refer to engine manual.
	Wrong fuel type.	Do not use gasoline containing ethanol.
	Poor fuel quality.	Store gasoline in a clean, plastic, sealed container approved for fuel storage. Close vent cap (if equipped) when not in use and store container away from direct sunlight. If fuel is stored longer than three months, adding a fuel stabilizer is recommended.
Electrical functions are not working properly.	Dirty air filter.	Clean or replace the filter.
	Battery cable or battery.	Check battery cable and make sure battery is fully charged.
DEF pump is not working properly.	Improper ground.	Check for proper grounding of electrical circuit.
	Pump is not working.	The DEF pump is for intermittent duty only. Once the maximum thermal limit is reached, the motor must be allowed to return to ambient temperature before resuming operation.
		Pump will not start.
	Pump will not prime. (no discharge but motor runs)	DEF tank is empty.
		Inlet or outlet pipes and/or hose are blocked with debris.
		Check for severe vacuum leak.
		Check for proper Voltage with the pump operating ($\pm 10\%$).
	Pump leaks.	Check pump for damage.
		Pump leaks.

PROBLEM	CAUSE	SOLUTION
Electric diesel fuel pump will not prime.	Suction line is damaged.	Check for leaks in suction line
	Fuel level in tank is below the pump inlet.	Maintain the fuel level above the height of the fuel pump inlet.
	Bypass valve open.	Valve problems; must move freely and be free of debris. Contact OEM for cleaning and/or repair options.
	Vanes sticking.	Vanes and slots may have nicks, burrs or wear. Contact OEM for repair options.
	Excessive rotor or vane wear.	Rotor and vane wear or damage. Contact OEM for repair options.
	Outlet blocked.	Check pump outlet, hose, nozzle, and filter for blockage.
	Vapor lock.	Check breather on top of tank for obstruction.
Electric diesel fuel pump low capacity.	Plugged filter.	Replace filter.
	Suction line problem.	Check suction line for leaks or restrictions or air leaks (not airtight).
	Bypass valve sticking.	Valve problems; must move freely and be free of debris. Contact OEM for cleaning and/or repair options.
	Vanes sticking.	Vanes and slots may have nicks, burrs or wear. Contact OEM for repair options.
	Excessive rotor or vane wear.	Rotor and vane wear or damage. Contact OEM for repair options.
	Hose or nozzle damage.	Replace hose or nozzle.
	Excessive dirt in screen.	Remove and clean screen.
	Low fluid level.	Fill tank.
Electric diesel fuel pump runs slowly.	Incorrect voltage.	Check incoming line voltage while pump is running. Must be 12 Volts.
	Vanes sticking.	Vanes and slots may have nicks, burrs or wear. Contact OEM for repair options.
	Wiring problem.	Check for loose connections.
	Motor problem.	Contact OEM for replacement options.
Electric diesel fuel pump stalls, fuse blows, or circuit breaker trips repeatedly.	Bypass valve sticking.	Valve problems; must move freely and be free of debris. Contact OEM for cleaning and/or repair options.
	Low voltage.	Check incoming line voltage while pump is running. Must be 12 Volts.
	Excessive rotor or vane wear.	Rotor and vane wear or damage. Contact OEM for repair options.
	Debris in pump cavity.	Clean debris from pump cavity.
Electric diesel fuel pump overheats.	Diesel fuel may be too viscose (too thick).	Viscous fluids can only be pumped for short periods of time (less than 30 minutes).
	Clogged screen.	Remove and clean screen.
	Restricted suction pipe.	Remove restriction.
	Motor failure.	Contact OEM for replacement options.
	Pump rotor lock-up.	Contact OEM for cleaning and/or repair options.

PROBLEM	CAUSE	SOLUTION
Electric diesel fuel pump does not operate.	No power.	Check incoming 12 Volt power source.
	Switch failure.	Replace switch with OEM parts.
	Motor failure.	Contact OEM for replacement options.
	Thermal protector failure.	Contact OEM for replacement options.
	Incorrect or loose wiring.	Repair wiring.
Electric diesel fuel pump leaks.	Bad O-ring gasket.	Replace all O-ring gaskets.
	Dirty shaft seal.	Clean seal and seal cavity.
	Bad shaft seal.	Replace seal.
	Incompatible fluid.	Do not pump any fluid other than diesel fuel.
	Loose fasteners.	Tighten fasteners.
Electric diesel fuel pump hums but will not operate.	Motor failure.	Contact OEM for replacement options.
	Broken key.	Remove all debris and replace key.
Notes:	Notes:	Notes:

16. WARRANTY

16.1 WARRANTY STATEMENT

Limited Materials and Workmanship Warranty For Fuel Trailers

Meridian Manufacturing Inc. (hereinafter referred to as the Manufacturer) hereby warrants the Fuel Trailer(s) sold by it to be free from any defect in material or workmanship under normal use and service for a period of one (1) year from the date of shipment. The Manufacturer's obligation under this warranty shall be limited to the repair or replacement only, FOB the original point of shipment, of any defective parts or portions of the fuel trailer or accessories manufactured by Meridian. Any warranty claim must be reported to the Manufacturer within one (1) year from the date of shipment.

THIS WARRANTY IS SUBJECT TO THE FOLLOWING LIMITATIONS, PROVISIONS AND CONDITIONS:

1. This warranty does not apply:
 - a) To any product sold by the Manufacturer where it is used in areas exposed to corrosive or aggressive conditions including salt water, acids, alkaloid, ash, cement dust, animal waste or other corrosive chemicals from either inside or outside the bin.
 - b) For failures or defects arising out of damage during shipment or during storage on site.
 - c) To materials replaced or repaired under this warranty except to the extent of the remainder of the applicable warranty.
 - d) To damage resulting from misuse, negligence, accident or improper site preparation by others.
 - e) If the product has been altered or modified by others.
 - f) If in the case of coating failures the failure is the result of damage, lack of proper maintenance or failure to remove road salt or other contaminants that may have come in contact with the bin surface.
 - g) To loss of time, inconvenience, loss of material, down time or any other consequential damage.
 - h) For a function that is different than original designed intent.
2. The obligation of the Manufacturer under this warranty shall not arise unless the Manufacturer is notified and this warranty is presented together with a written statement specifying the claim or defect within thirty (30) days after the failure is first detected or made known to the owner and within one (1) year from the shipment date. The Manufacturer in its sole discretion shall determine if the claim is valid and whether correction of the defect or failure shall be made by repair or replacement of the materials.
3. The coating warranty is based on the manufacturer's performance specification for Polyester Powder finishes and does not include repair of minor blemishes or rusting that is normally part of the general maintenance of the fuel trailer. This warranty does not cover excessive wear on interior coatings. See attachment for full Performance Specification details on Polyester Powder Finishes.
4. The obligation of the Manufacturer hereunder extends only to the original owner and to the Meridian dealer to whom the materials may have been initially sold. This warranty shall not be subject to any assignment or transfer without the written consent of the Manufacturer.
5. The customer shall acknowledge that it has made its own independent decision to approve the use of the supplied materials and also the specific fabrication and construction procedures utilized to complete the fuel trailer, and has satisfied itself as to the suitability of these products for this particular application.
6. The foregoing sets forth the only warranties applicable to said materials and said warranties are given expressly and in lieu of all other warranties, expressed or implied, statutory or otherwise, of merchantability or fitness for a particular purpose and all warranties which exceed or differ from said warranties herein are disclaimed by the Manufacturer.
7. The owners sole and exclusive remedy against the Manufacturer shall be limited to the applicable warranty set forth herein and the endorsements, if any, issued together with this document and no other remedy (including but not limited to the recovery of assembly or disassembly costs, shipping costs, direct, incidental, special, indirect or consequential damages for lost profits, lost sales, injury to person or property or any other loss, whether arising from breach of contract, breach of warranty, tort, including negligence, strict liability or otherwise) shall be available to the owner or Meridian Dealer or any other person or entities whether by direct action or for contribution or indemnity or otherwise.
8. The financial obligation of the Manufacturer under this warranty shall be limited to the repair or replacement of the product as originally supplied and in no event shall exceed the original cost of the product supplied.
9. The Manufacturer shall not have any obligation under any warranty herein until all accounts for materials, installation and erection of the said product thereof and for labor and other work performed by the Manufacturer or its dealers have been paid in full by the owner.

Warranty Claim Procedure

1. Registering product with Meridian Manufacturing.
2. Contact the dealer unit was purchased from upon discovery of any defects.
3. A completed warranty claim form submitted by dealer to Meridian warranty representative for review and course of action.
4. Warranty repair work will only be performed by Meridian, the dealer or an approved representative. No warranty work completed prior to approval. Failure to follow procedure may affect any or all reimbursement.
5. Claims will be adjudicated at the sole discretion of the manufacturer and in accordance with the terms and conditions of the applicable limited warranty.
6. A complete list of warranty procedures can be procured from the Warranty Department or found in your owner's manual.

Effective July 1, 2014

17. PARTS

The following pages contain a list of serviceable parts for the Fuel Trailer unit.

Parts are available from your authorized Dealer Parts Department.

17.1 DIESEL FUEL PUMP, ENGINE

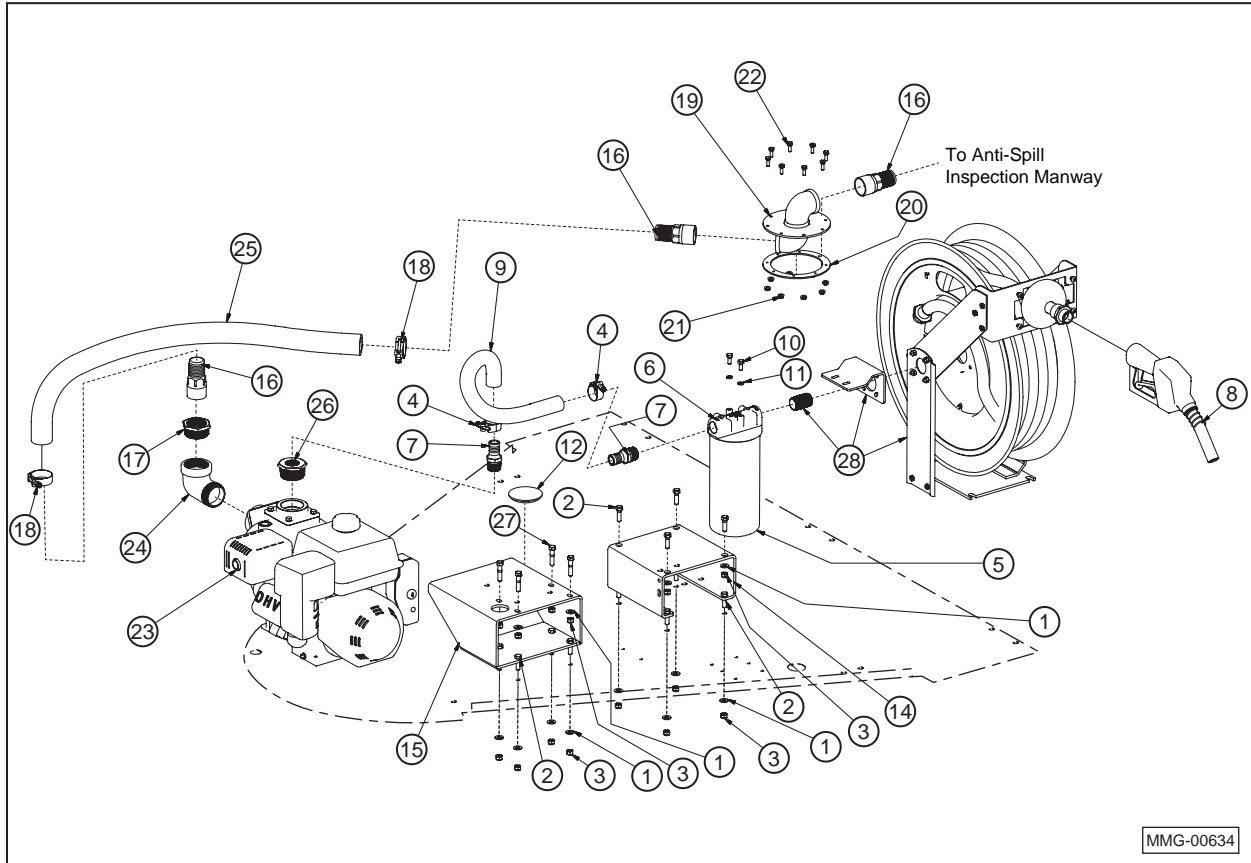

Item	Qty.	Part No.	Description
1	16	19348	WASHER, FLAT, 3/8"
2	12	19326	BOLT, HEX, 3/8-16 x 1-1/4"
3	16	19347	NUT, LOCK, 3/8-16 NYLON
4	2	11513	Clamp, T-Bolt, 1.344" to 1.562"
5	1	11220	Diesel Filter - 40 GPM-50 PSI 10 Micron
6	1	25173	Filter Head 1" NPT for F40 Filter (700ACCF7017)
7	2	11506	1" Hose Nipple W 1" M NPT Thd 304 SS
8	1	21020	Diesel Nozzle 1" Outlet (Fill-Rite) Green
9	1	17516	Hose, Diesel, 1" ID, Puma (Pump to Filter)
10	2	19309	Bolt, Hex, 5/16-18 x 3/4"
11	2	19322	Washer, Lock, 5/16"
12	1	17517	Plug, Plastic, for 3" Hole
13	—	—	(Not Used)
14	1	25178	Diesel Reel Mount

Item	Qty.	Part No.	Description
15	1	32444	Engine/Pump Mount Weldment
16	3	17392	Fitting, Barbed, 1-1/2 NPT
17	1	17393	Reducer, 2 x 1-1/2 NPT, Brass
18	2	17380	Clamp, T-Bolt, 1.844" to 2.062"
19	1	34509	Elbow Flange Weldment
20	1	19055	View Glass Gasket
21	8	19126	Nut, Hex, Flanged 1/4-20
22	8	19560	Bolt, Hex, 1/4-20 x 3/4"
23	1	11074	Engine, 6.5 HP, Pump, MP-40 GPM
24	1	17790	Elbow 2 NPT 304SS 90 Female x Male
25	1	17515	Hose, Diesel, 1-1/2" ID, Puma, (S-bend to Pump)
26	1	11517	Reducer, 2" NPT M x 1" NPT F, 304SS
27	4	19618	Bolt, Hex 3/8-16 x 1-3/4" Steel
28	1	68702	Diesel Hose Reel 50', (Cox Reel)

17.2 DIESEL FUEL PUMP, 12VDC

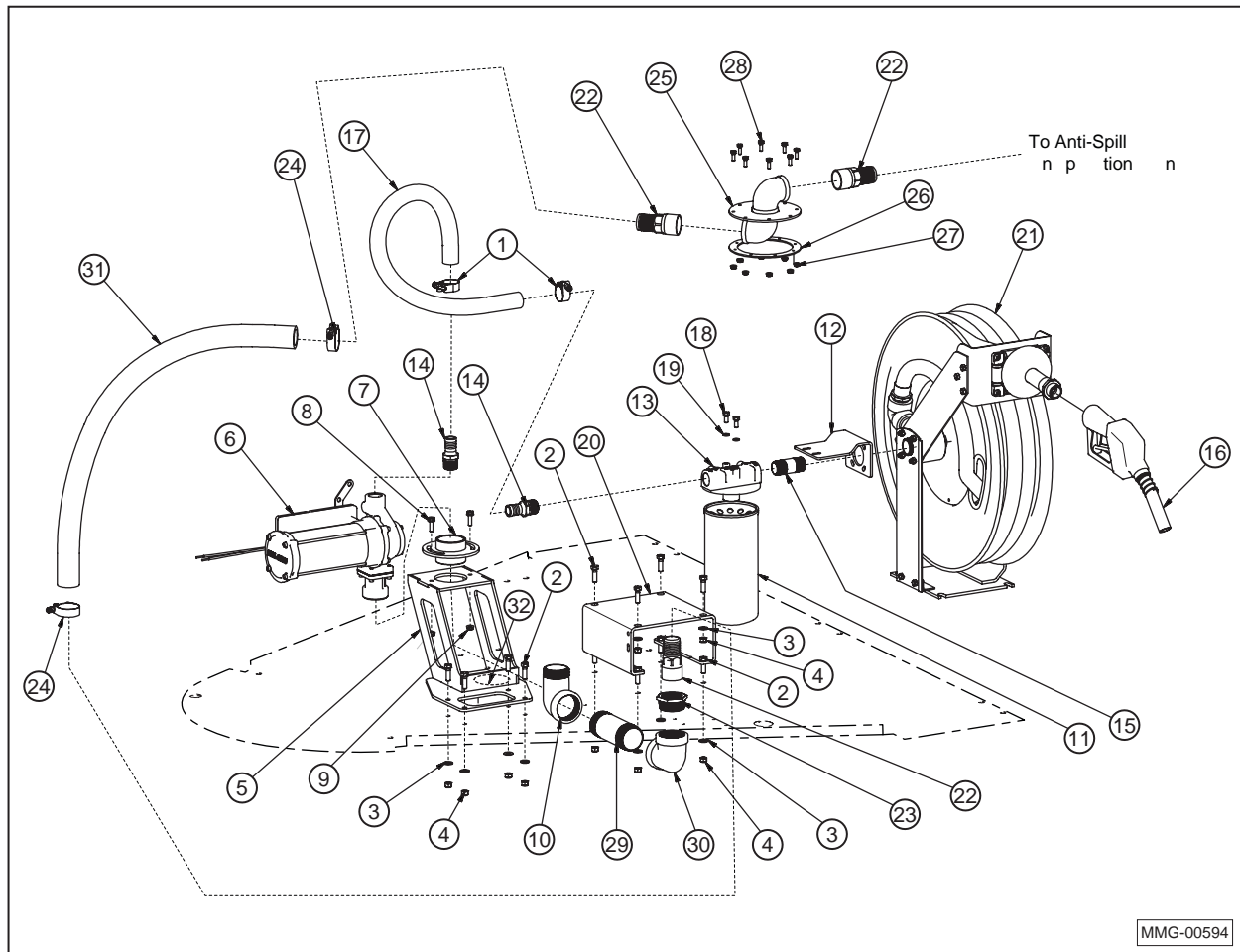

Item	Qty.	Part No.	Description
1	2	11513	T-Bolt Clamp - 1.344" TO 1.562"
2	12	19326	Bolt, Hex, 3/8-16 x 1-1/4" Steel
3	12	19348	Washer, Flat 3/8
4	12	19347	3/8-16 Nylon Locknut
5	1	32440	Pump Mount Weldment - 12V Diesel Pump
6	1	11500	Diesel Pump 12V, 25 GPM (Fill-Rite)
7	8	32439	Coupler Weldment - 12V Diesel Pump Mount
8	2	19581	Bolt, Hex, Flanged 5/16-18 x 1"
9	2	19318	Nut, Hex, Flanged 5/16-18
10	1	17790	Elbow 2 NPT 304SS 90 Female x Male
11	1	11220	Diesel Filter - 40 GPM-50 PSI 10 Micron
12	1	25176	Filter Head Mount
13	1	25173	Filter Head 1" NPT for F40 Filter (700ACCF7017)
14	2	11506	1" Hose Nipple W 1" M NPT Thd 304 SS
15	1	11516	1" Sch 40 Nipple 3" Long 304 SS
16	1	21020	Diesel Nozzle 1" Outlet (Fill-Rite) Green

Item	Qty.	Part No.	Description
17	1	17518	Hose, Diesel, 1" ID, Puma
18	2	19309	Bolt, Hex, 5/16-18 x 3/4"
19	2	19322	Washer, Helical Spring Lock, 5/16"
20	1	25178	Diesel Reel Mount
21	1	11205 68702	Diesel Hose Reel 35', (Cox Reel) Diesel Hose Reel 50', (Upgrade Kit)
22	3	17392	Fitting, Barbed, 1-1/2 NPT
23	1	17393	Reducer, 2 x 1-1/2 NPT, Brass
24	2	17380	Clamp, T-Bolt, 1.844" to 2.062"
25	1	34509	Elbow Flange Weldment
26	1	19055	View Glass Gasket
27	8	19126	Nut, Hex, Flanged 1/4-20
28	8	19560	Bolt, Hex, 1/4-20 x 3/4"
29	1	17520	Fitting, Nipple 2" NPT x 6" L, 304 SS
30	1	18858	Fitting, Elbow 2" NPT F x F, 304 SS
31	1	17519	Hose, Diesel, 1-1/2" ID, Puma
32	1	17517	Plug, Plastic, for 3" Hole

17.3 DEF PUMP ASSEMBLY

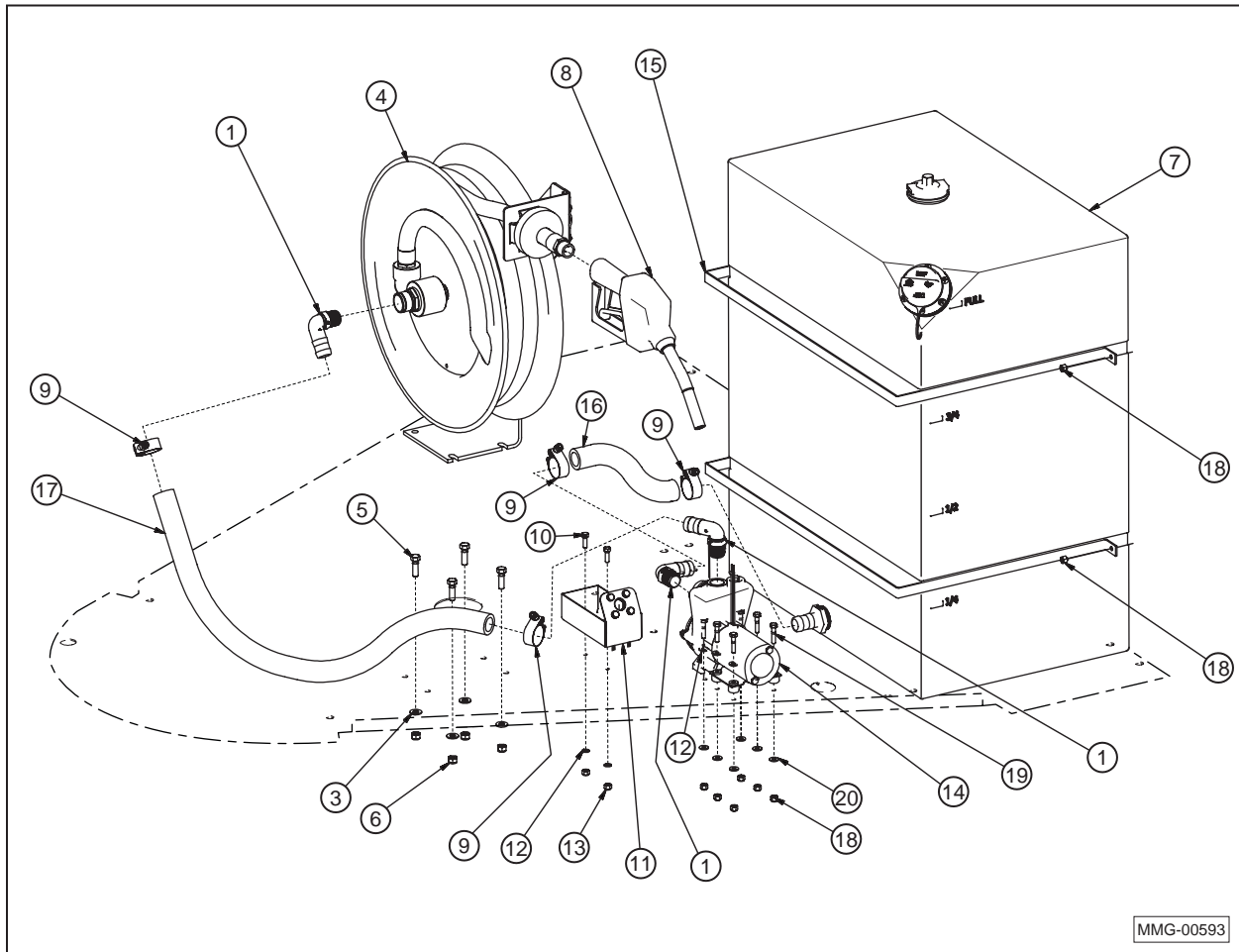

Item	Qty.	Part No.	Description
1	3	25176	Fitting, Elbow, Barb, 1 x 3/4 NPT
2	—	—	(Not Used)
3	4	19348	Washer, Flat, 3/8
4	1	68708	DEF Hose Reel, 25' (Cox Reel)
5	4	19326	Bolt, Hex, 3/8-16 x 1-1/4, Steel
6	4	19347	3/8-16 UNC Nylon Locknut
7	1	32097	DEF Tank Assembly, 55 Gal., Plastic
8	1	11207	DEF Nozzle, 3/4" Outlet (FRNS075A)
9	4	11513	Clamp, T-Bolt, 1.344" to 1.562"
10	2	19099	Bolt, Hex 1/4-20 x 7/8" Steel

Item	Qty.	Part No.	Description
11	1	32430	DEF Nozzle Holster Assembly
12	2	17767	Washer, Flat, 1/4" SS
13	2	18321	Nut, Hex 1/4-20 Nylon SS
14	1	10133	Pump, 12VDC, DEF, FRX-75-SP
15	2	24307	Strap, Tank, 990 DEF Tank
16	1	17514	Hose, DEF, 1" ID, Tank to Pump
17	1	17513	Hose, DEF, 1" ID, Pump to HR
18	10	19128	Nut, Hex 1/4-20 Nylon
19	6	17900	Bolt, Hex 1/4-20 x 1-1/4" Steel
20	12	19307	Washer, Flat, 1/4

17.4 DEF TANK ASSEMBLY

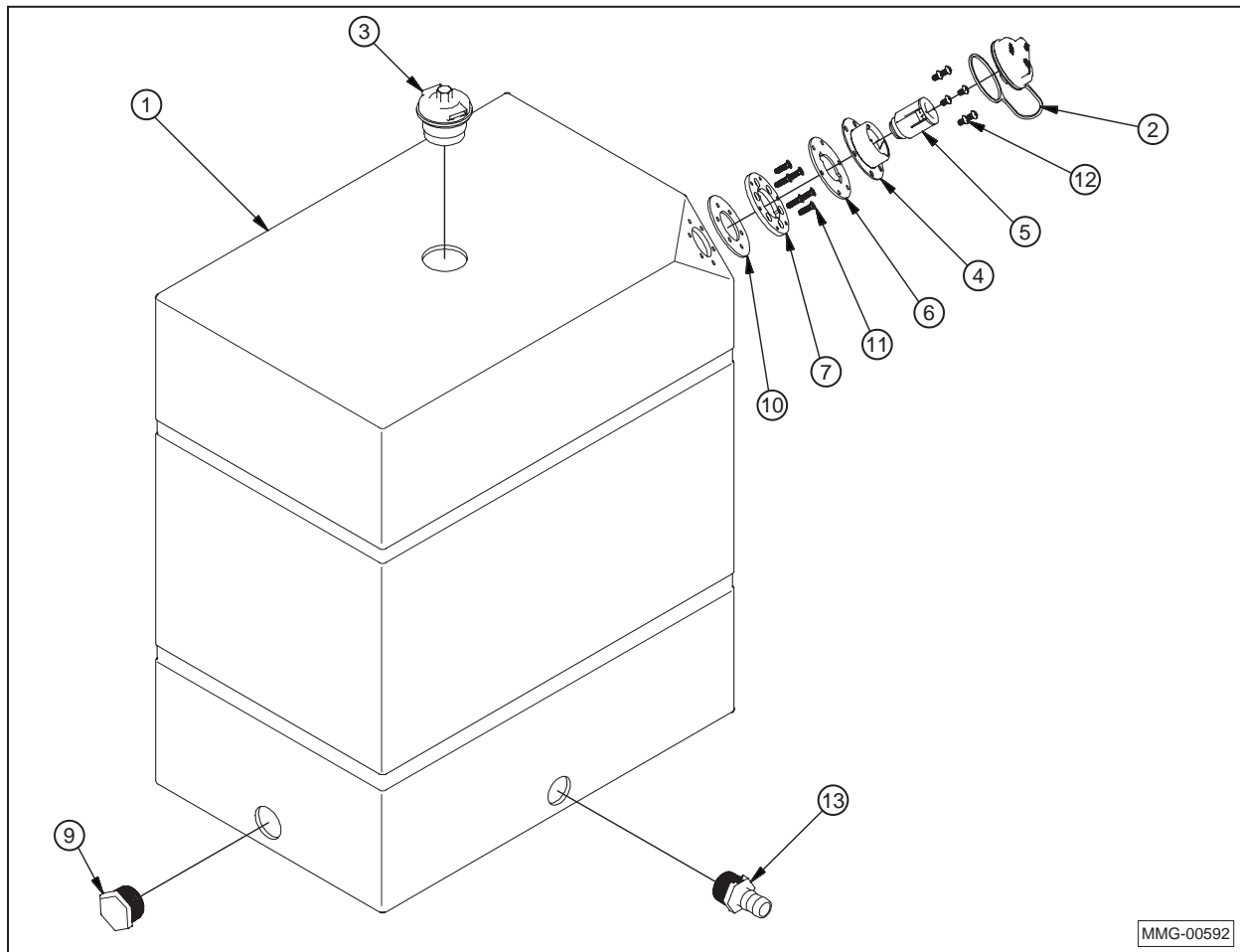

Item	Qty.	Part No.	Description
1	1	11542	DEF Tank, 55 gal.
2		11221	DEF Cap, Vented
3	1	11213	2" Dia. NPS Dual Action Vent (4 PSI)
4	1	38670	Filler Neck Top Weldment SS
5	1	17348	OPW21GU Mis-filling Prevention Device
6	1	17343	Fill Neck Top Gasket
7	1	17345	Fill Neck Bolt Plate Bottom
8	—	—	(Not Used)
9	1	17353	Plug, 1-1/2" NPT Sch 80
10	1	17344	Fill Neck Bottom Gasket
11	6	17346	Screw, Phillips, 1/4-20 x 7/8 SS Flat
12	6	17347	Screw, Phillips, 1/4-20 x 3/8 SS Round
13	1	17351	Hose Barb, 1-1/4" x 1" NPT Sch 80

17.5 ANTI-SPILL INSPECTION MANWAY

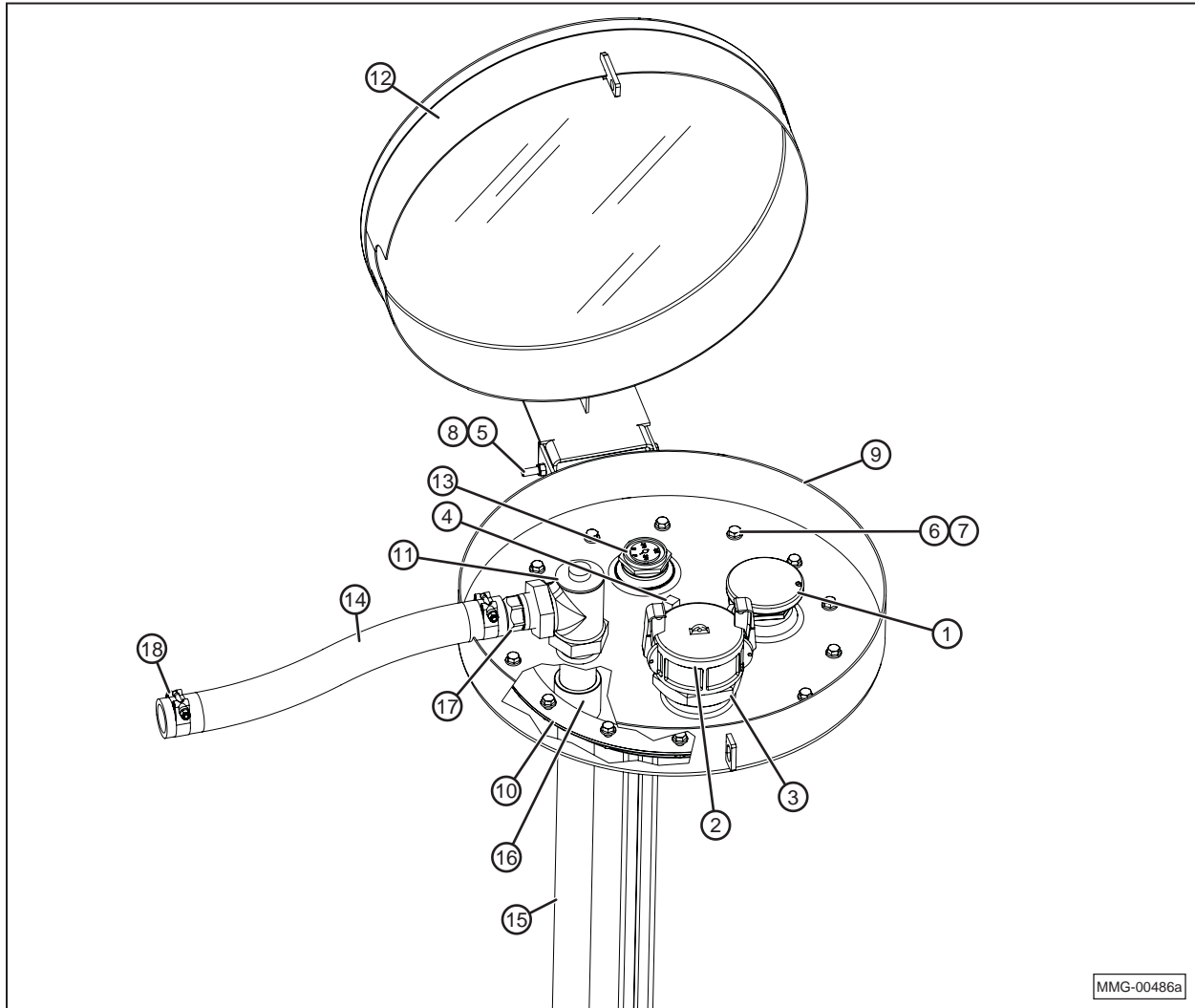

Item	Qty.	Part No.	Description
1	1	11527	Vapor Control Cap, 2" NPT
2	1	18740	Cap, Dust, Female, 3" Camlock
3	1	18953	Coupler, Female, Camlock, 3" NPT - Male
4	1	18006	Plug, Square Head, 3/4"
5	1	19333	Bolt, Hex, 3/8-16 x 7" long
6	14	19564	Nut, Hex, Flanged, 3/8-16
7	14	19569	Bolt, Hex, Flanged, 3/8-16 x 1" long
8	1	19347	Locknut, Nylon, 3/8-16
9	1	*31519XX	Manway, Anti-Spill Inspection, Weldment
10	1	14176	Gasket, Neoprene
11	1	14172	Valve, Anti-Siphon, 1-1/2" NPT
12	1	*17397XX	Manway, Lid Weldment
13	1	31518	Dial, Vertical Level Gauge

Item	Qty.	Part No.	Description
14	1	14173	Hose, Suction
15	1	22766	Pipe, Suction, 1-1/2" SCH 40 x 32" long
16	1	18853	Coupler, Full, 1-1/2" NPT, MS
17	1	17392	Fitting, Barbed, 1-1/2 NPT
18	2	17380	Clamp, T-Bolt, 1.844" to 2.062"

*Color of painted components is denoted by a two letter suffix as follows. MR - Meridian Red, BW - Bone White, GR - Grey.

17.6 GENERATOR/WELDER/COMPRESSOR OPTION (3-IN-1)

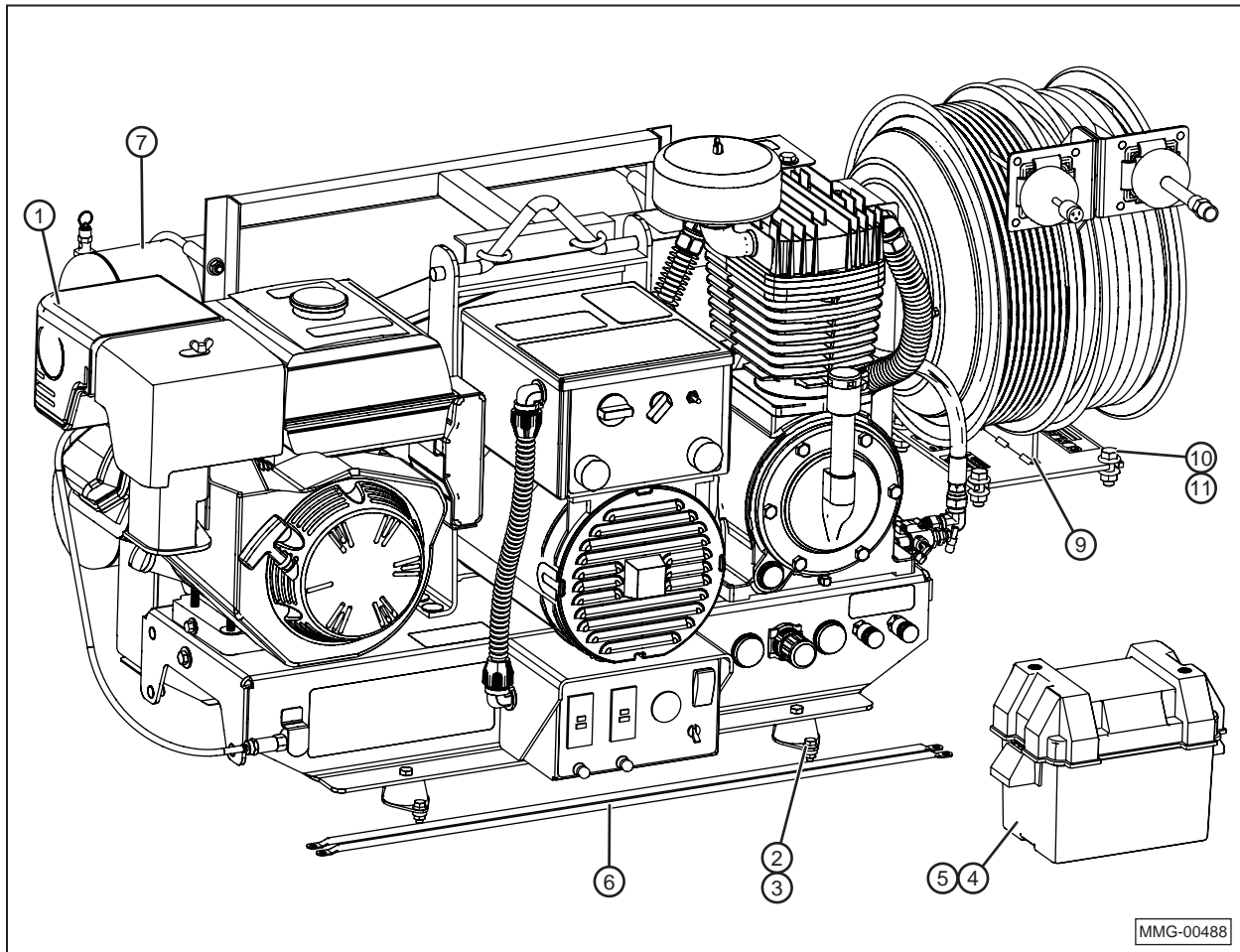

Item	Qty.	Part No.	Description
1	1	17409	Generator/Welder/Compressor Combo
2	8	19318	Nut, Hex, Flanged, 5/16-18
3	8	19568	Bolt, Hex, Flanged, 5/16-18 X 3/4"
4	1	21286-00	Battery, SP-30
5	1	11219	Box, Battery, Small
6	1	18658	Cable, Battery Set (33-1/2")
7	1	34510	Tank Assembly, Air, Twin 8 Gallon
9	1	11075	Reel, Dual, Air/Electrical
10	4	19595	Nut, Hex, Flanged, 1/2-13
11	4	18943	Bolt, Hex, Flanged, Steel, Mild 1/2-13 x 1-1/4" long

17.7 GENERATOR/COMPRESSOR OPTION (2-IN-1)

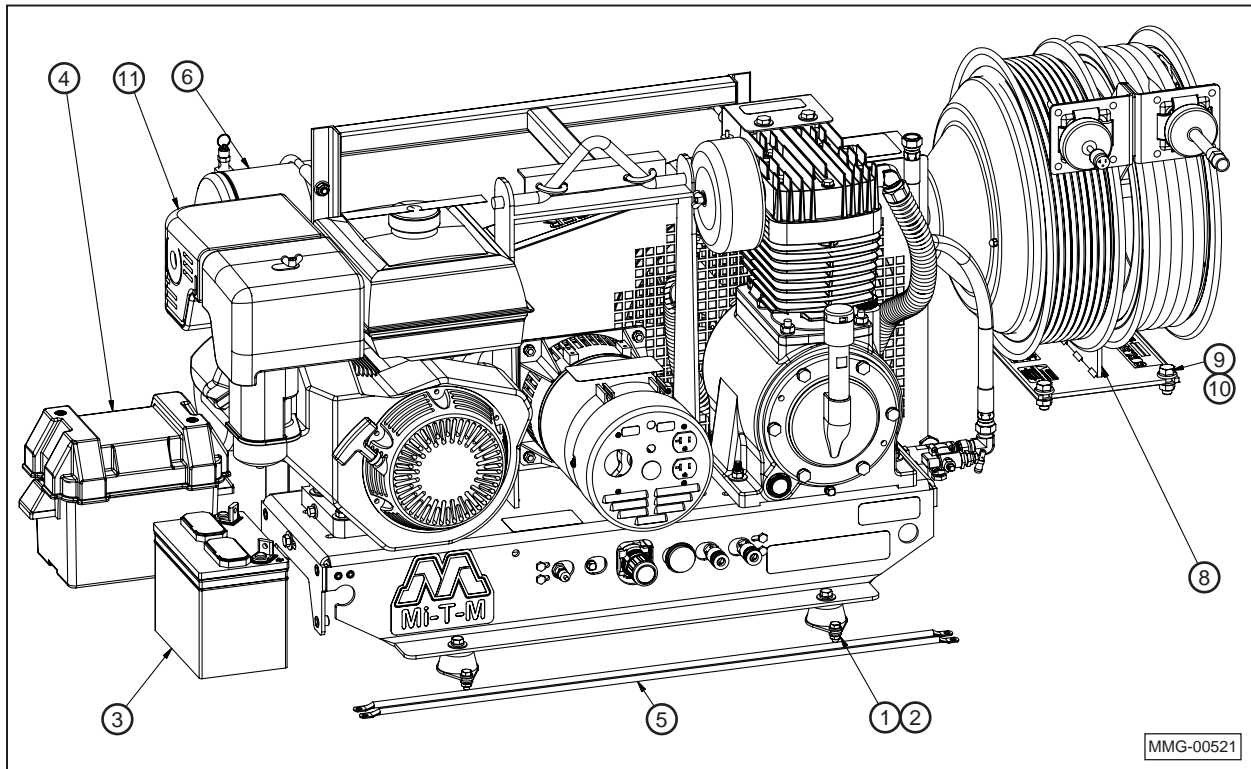

Item	Qty.	Part No.	Description
1	8	19318	Nut, Hex, Flanged, 5/16-18
2	8	19568	Bolt, Hex, Flanged, 5/16-18 X 3/4"
3	1	21286-00	Battery, SP-30
4	1	11219	Box, Battery, Small
5	1	18658	Cable, Battery Set (33-1/2")
6	1	34510	Tank Assembly, Air, Twin 8 Gallon
7	—	—	(Not Used)
8	1	11075	Reel, Dual, Air/Electrical
9	4	19595	Nut, Hex, Flanged, 1/2-13
10	4	18943	Bolt, Hex, Flanged, Steel, Mild 1/2-13 x 1-1/4" long
11	10	17505	Generator/Compressor Combo

17.8 DECALS AND SAFETY SIGNS

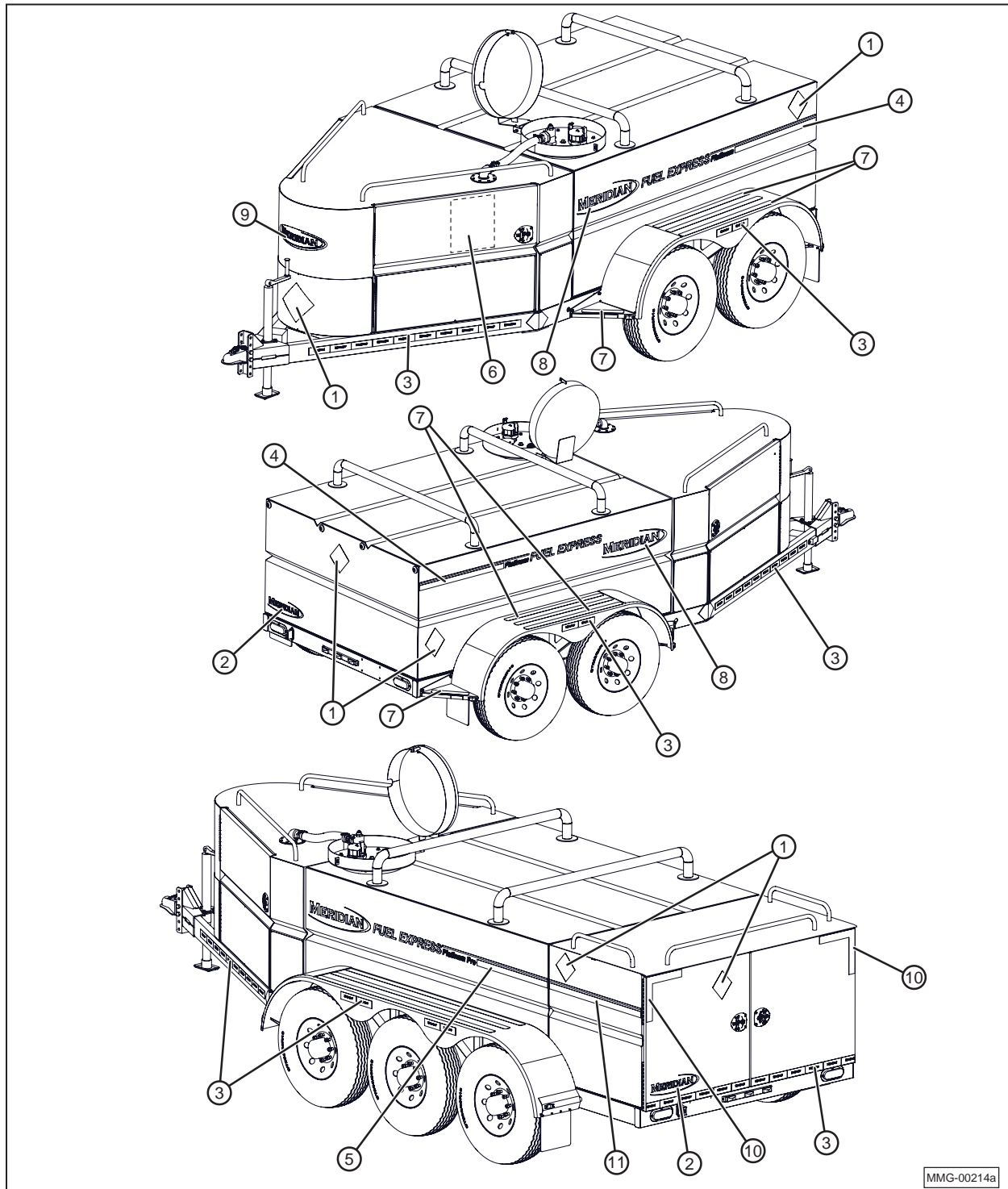

MMG-00214a

Item	Qty.	Part No.	Description
1	4	17546 17547	UN 1202 Placard, Decal, Diesel UN 1203 Placard, Decal, Gasoline
2	1	19911	Meridian Trailer White Decal
3	—	18096	Tape Reflective Meridian 2X6X6
4	2	17525 17419	Fuel Express Trailer Decal Fuel Express Platinum Decal
5	2	17416	Fuel Express Platinum Pro Decal
6	1	17553	Decal, Warning (inside door)
7	10	18118	Tape, Fender Anti-slip

Item	Qty.	Part No.	Description
8	2	17508	Meridian Trailer White Decal
9	1	*17728XX	Meridian Trailer Cowling Decal
10	2	17411	Decal, Corner, Reflective
11	2	17522	Stripe Decal, (White) Utility Box

*Color of painted components is denoted by a two letter suffix as follows. MR - Meridian Red, BW - Bone White, GR - Grey

17.9 UTILITY BOX ASSEMBLY

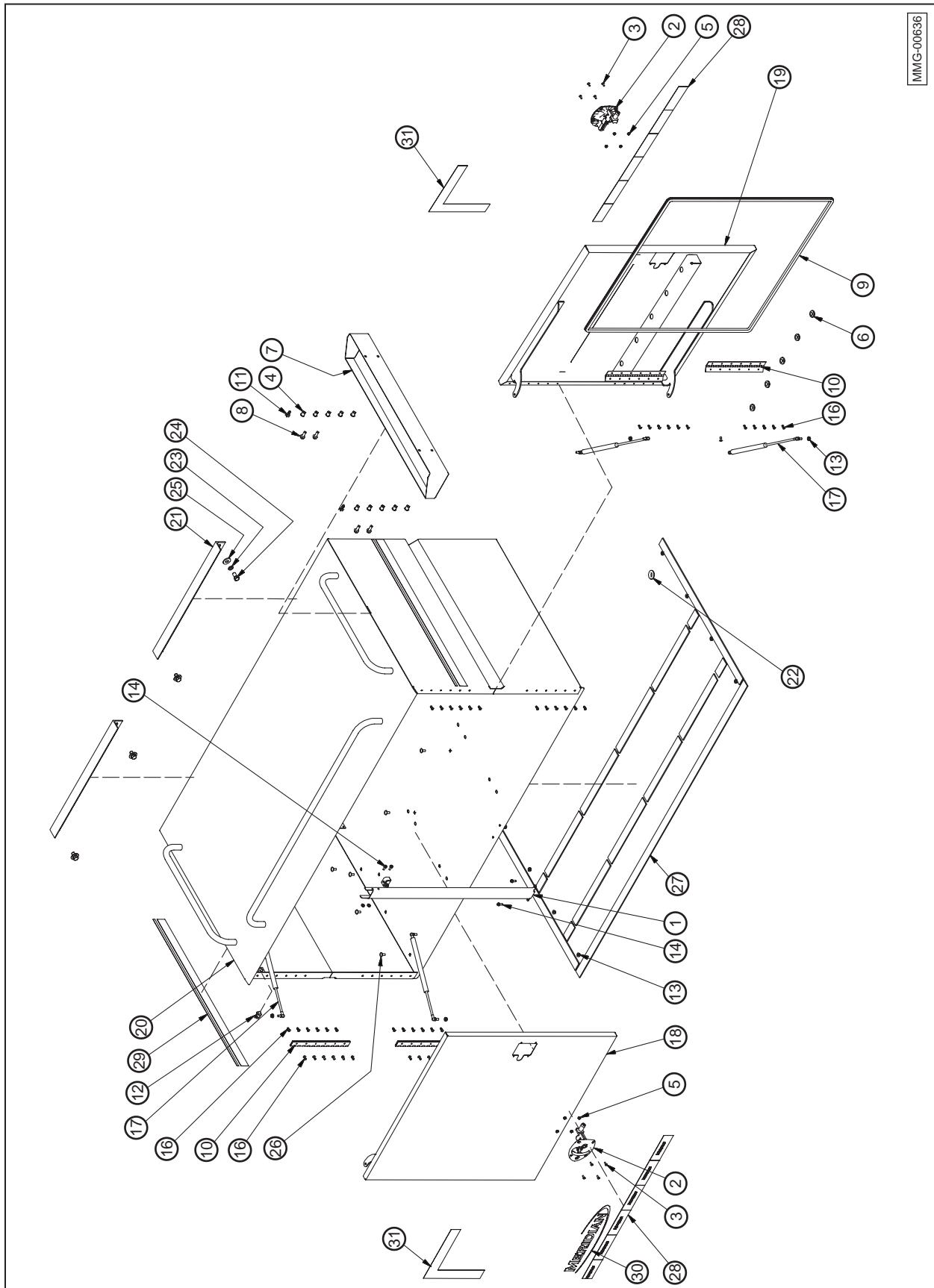

Item	Qty.	Part No.	Description
1	1	*22794XX	Bolt-In Mullion
2	2	11223	Vector T-Handle - Zinc Handle Finish
3	8	18941	Cross Recessed Pan Head Machine Screw - Type I
4	10	11550	Rivet Nut 3/8"-16 UNC
5	8	17722	Nylon, Nut, #10-32
6	10	14033	Grommet, 5/8"
7	1	*22793XX	Tool Caddy, Shelf, Utility Box
8	4	19569	Bolt, Hex, Flanged, 3/8-16 x 1
9	2	11230	Bulk Seal, 14" - 3/8", 90° x 1/8"
10	4	11222	SS Hinge Assy (1" x 12" L Drilled)
11	2	27055-00	Zip Tie Clip
12	2	11526	Button Switch
13	21	19318	Nut, Hex, Flanged, 5/16-18
14	8	17922	Bolt, Hex, Flanged, Steel, Mild 1/4-20 x 0.625
15	2	19126	Nut, Hex, Flanged, 1/4-20
16	48	19089	Protruding Head Style Break Mandrel Closed End Blind Rivet
17	4	11520	Gas Spring Assist Shock, 30 lb (20.13 Ext)

Item	Qty.	Part No.	Description
18	1	*32103XX	Door Weldment, DS, Utility Box
19	1	*32104XX	Door Weldment, PS, Utility Box
20	1	*32102XX	Utility Box Weldment
21	2	*22889XX	Utility Box Angle Mount
22	1	17065	Grommet, 1-1/8" x 3/4" ID
23	4	19373	Lock Washer, 1/2"
24	4	19354	Bolt, Hex, 1/2-13 x 1
25	4	18487	Washer, 1/2 - Wide - Type A Steel, Mild
26	13	19315	Bolt, Carriage 5/16-18 x 0.75
27	1	11228	Neoprene Strip, 18' - 3/16" x 1 1/2"
28	6ft	18096	Tape Reflective Meridian 2 x 6 x 6
29	2	17522	Stripe Decal, (White) Utility Box
30	1	19911	Meridian Trailer White Decal
31	2	17411	Decal, Corner, Reflective

*Color of painted components is denoted by a two letter suffix as follows. MR - Meridian Red, BW - Bone White, GR - Grey

17.10 SPARE TIRE OPTION

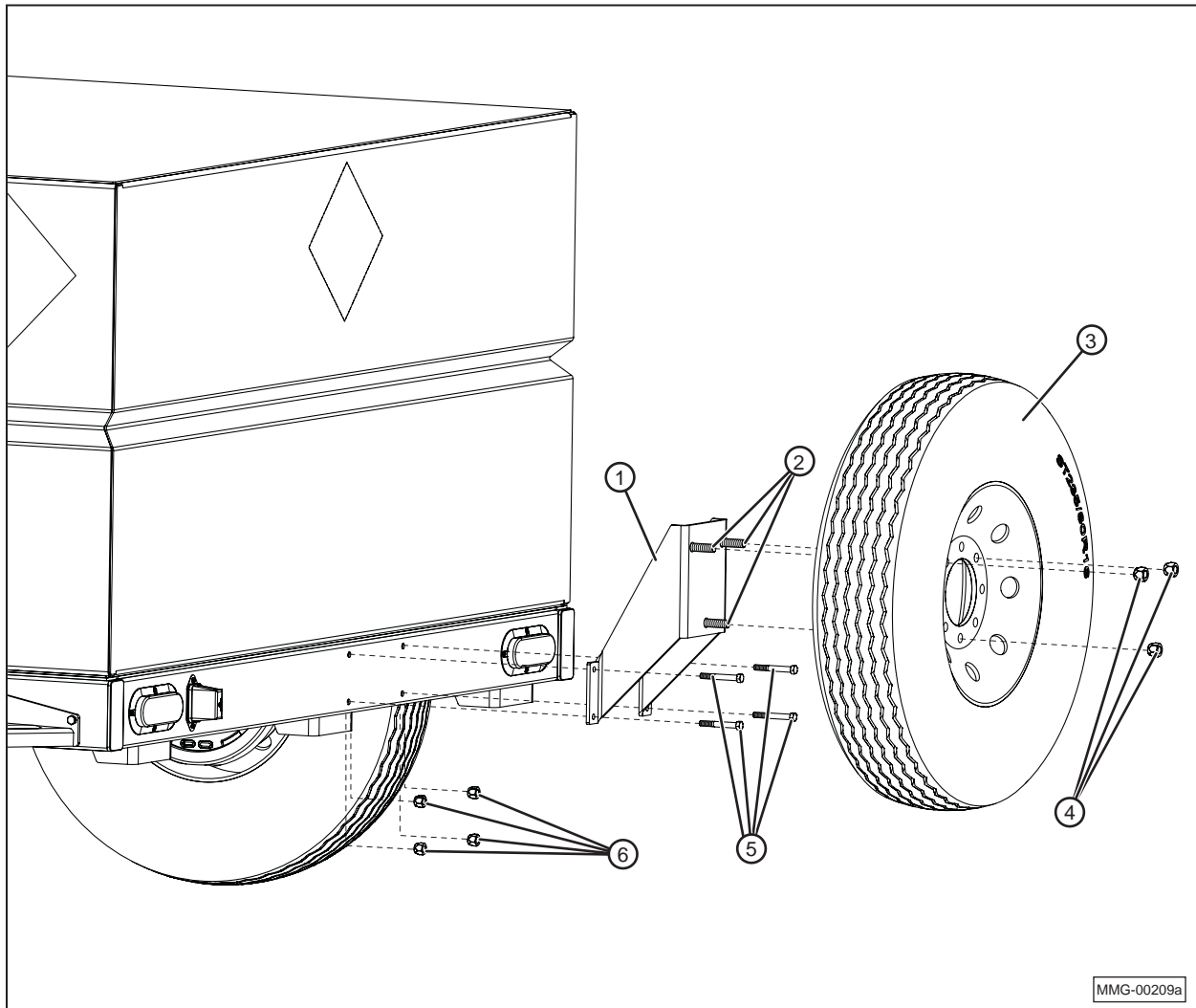

Item	Qty.	Part No.	Description
1	1	24109	Bolt On Spare Tire Mount
2	3	18992	Ø9/16"-18 UNF X 2" H.H.C.S.
3	1	18131 17756	ST235/80R16, Tire and Steel Rim ST235/80R16-E Tire, Aluminum Rim Assembly
4	3	18991	Ø9/16-18 UNF x 3/4" Lug Nut
5	4	19330	Bolt, Hex, 3/8-16 UNC X 3 Steel, Mild
6	4	19564	Nut, Hex, Flanged, 3/8-16 UNC
—	—	68706	Spare Tire Kit (Steel)
—	—	68707	Spare Tire Kit (Aluminum)

Note: Spare tire option is available for tandem axle trailers only.

17.11 COWLING ASSEMBLY

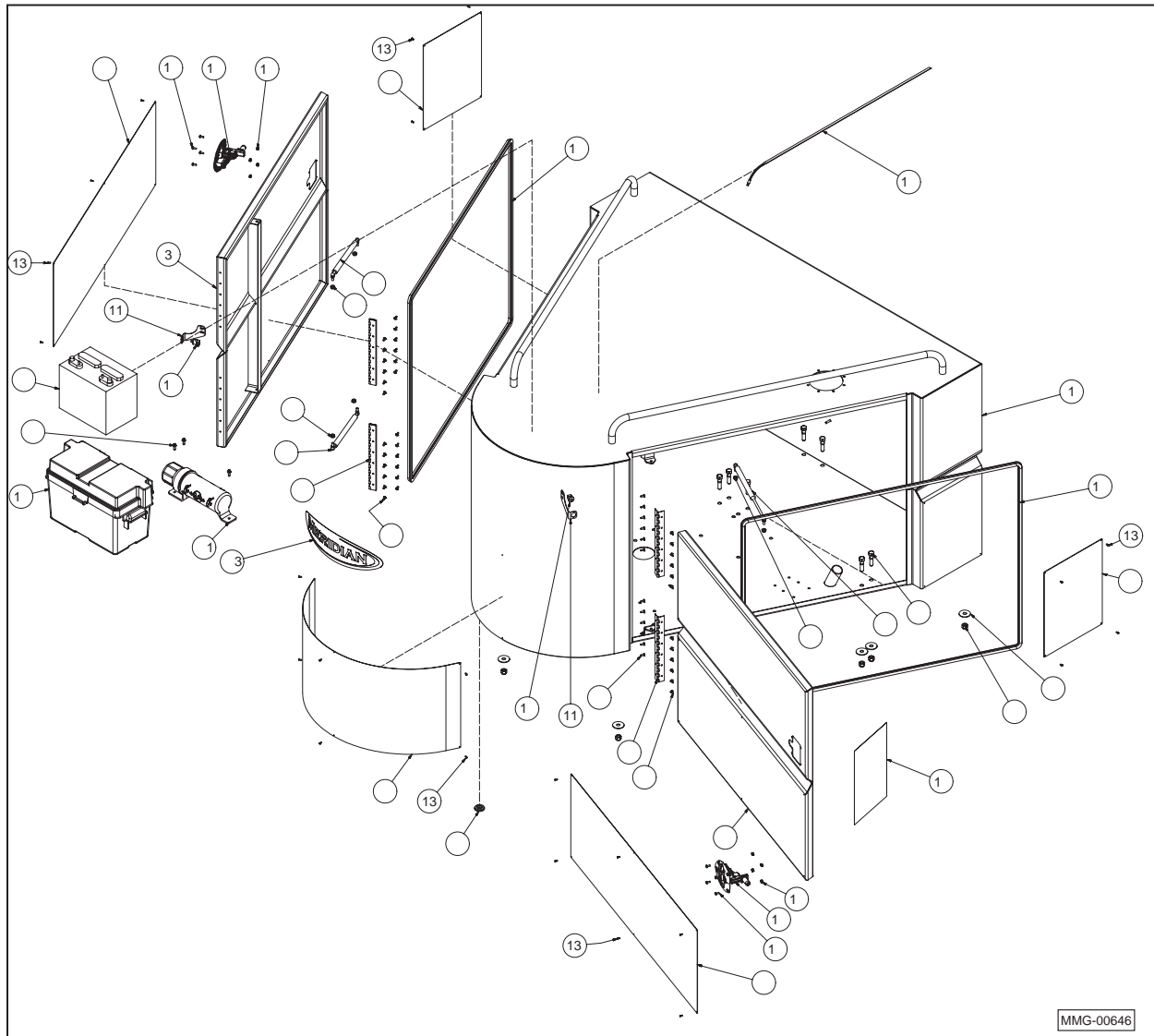

Item	Qty.	Part No.	Description
1	1	*32434XX	Cowling Weldment
2	1	*32436XX	DS Door Weldment
3	1	*32435XX	PS Door Weldment
4	4	11222	SS Hinge (1" x 12" L Drilled)
5	1	24954	Alum. Rock Guard - Nose
6	2	24955	Alum. Rock Guard - Door
7	2	24956	Alum. Rock Guard - Side Panel
8	4	11206	30lb Gas Shock/Spring 15.24" Ext.
9	8	19318	Nut, Hex, Flanged, 5/16-18 UNC
10	2	11223	Vector T-Handle - Zinc Handle Finish
11	2	*24990XX	Button Switch Mount
12	2	11526	Button Switch
13	26	17041	Ø1/8" Aluminum Rivet - .126-.187 Grip
14	8	18941	Cross Recessed Pan Head Machine Screw - Type I
15	8	17722	Nut, Nylon, #10-32 UNF
16	2	11230	Bulb Seal, 14" - 3/8", 90° x 1/8"

Item	Qty.	Part No.	Description
17	1	17553	Decal, Warning (inside door)
18	1	11505	LED Strip, Self Adhesive, 36"
19	3	11218	Box, Battery, Large
20	3	19597	Screw, Hex Washer Hd, Self Drilling, 1/4-14 x 3/4
21	1	18128	Holder for Manual, OMC-1
22	1	11525	Cowling Wire Harness (Not Shown)
23	1	*17728XX	Meridian Trailer Cowling Decal
24	48	19129	Rivet, Ø3/16", 1/8" - 1/4" Grip, SS
25	1	17065	Grommet, 1-1/8" x 3/4" ID
26	13	19356	Bolt, Hex, 1/2-13 x 2"
27	13	17793	Washer, Flat, 1/2"
28	13	19127	Locknut, Hex, 1/2-13, Nylon
29	1	17398	Battery, Marine, 24M-RD, 400 CCA

*Color of painted components is denoted by a two letter suffix as follows. MR - Meridian Red, BW - Bone White, GR - Grey

17.12 TANDEM AXLE TRAILER

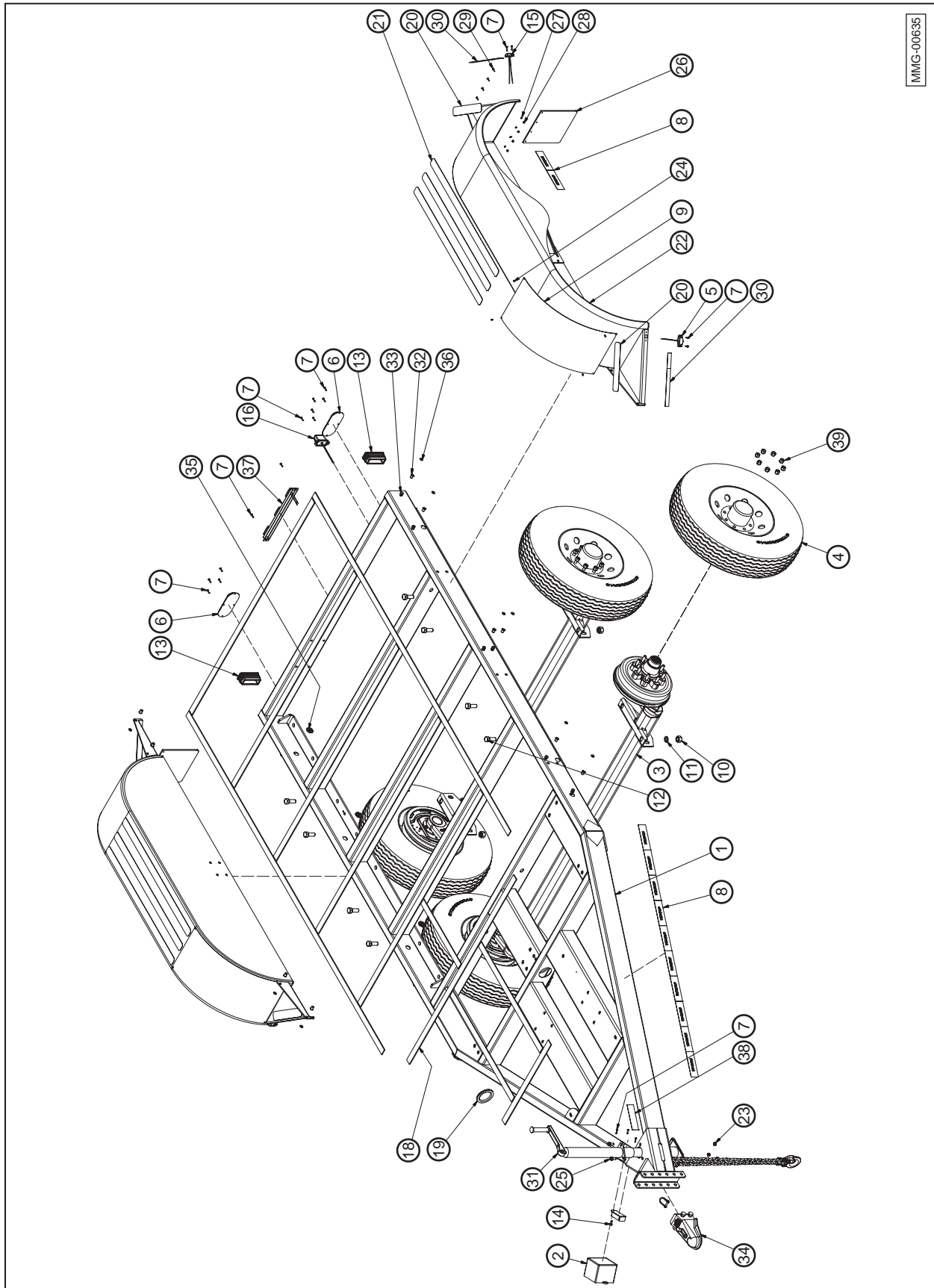

Item	Qty.	Part No.	Description
1	1	32038	Frame Weldment, 990 Fuel Trailer
2	1	19275	Battery Breakaway, BA10-150
3	2	18193	Axle, 7000 lbs.
4	4	18131 17756	ST235/80R16, Tire and Steel Rim ST235/80R16-E, Tire, Aluminum Rim Assembly
5	2	18151	Clearance Light, Amber
6	2	18117	Tail Light, 10 Diode, (LED STL- 78RB)
7	23	19779	#8-18 X 3/4" Self Drilling Zinc Screw
8	12	18096	Tape, Reflective Meridian 2x6x6
9	2	22990	Fender, Aluminum Rock Guard, Tandem Axle, 14" W
10	8	19652	Nut, Hex, Heavy, 3/4-10 UNC
11	8	19396	Washer, Lock, Helical Spring 3/4"
12	8	19388	Bolt, Hex, 3/4-10 x 2"
13	2	19619	Plug, Tube, 2" x 5"
14	1	19597	Screw, Hex Washer Hd, Self Drilling, 1/4-14 x 3/4
15	2	18229	Clearance Light, Red
16	1	17209	License Plate Light, Chrome, 5 Diode
17	1	14065	Wire Harness, Fuel Trailer (Not Shown)
18	—	—	Neoprene Strip, 3/16 x 1-1/2 (60' 6")
19	4	14062	Edging, Neoprene
20	4	18118	Tape, Anti-Slip, Step Side, Fuel Trailer

Item	Qty.	Part No.	Description
21	6	18118	Tape, Anti-Slip, Fender, Fuel Trailer
22	2	22903	Fender Weldment, Tandem Axle, 14" W
23	3	19564	Nut, Hex, Flanged, 3/8-16 UNC
24	8	17041	Ø1/8" Aluminum Rivet - .126-.187 Grip
25	3	19569	Bolt, Hex, Flanged, 3/8-16 x 1"
26	2	19274	Flap, Mud
27	8	19629	Washer, Flat, 5/32" Dia.
28	8	19112	Nut, Hex, #8-32 Nylon
29	8	19141	Screw, Round Head Pan, #8-32 x 5/8
30	4	18153	12" - 1" DOT Reflective Tape
31	1	18192	Jack, Top-Wind (5000 lb. CAP.)
32	12	11550	Rivet Nut 3/8"-16 UNC
33	12	11551	Screw, Cap, 3/8-16 x 1-1/4" With Loctite
34	1	24688	Hitch Coupler 2-5/16" Adjustable
35	3	17065	Grommet, 1-1/8" x 3/4"
36	12	19349	Washer, Lock, 3/8" Dia.
37	1	11554	Strip Light, LED (Truck-Lite 15050R)
38	1	17532	Decal, Trailer VIN# Template
39	32	18991	Ø9/16-18 UNF x 3/4" Lug Nut

17.13 TRIPLE AXLE TRAILER

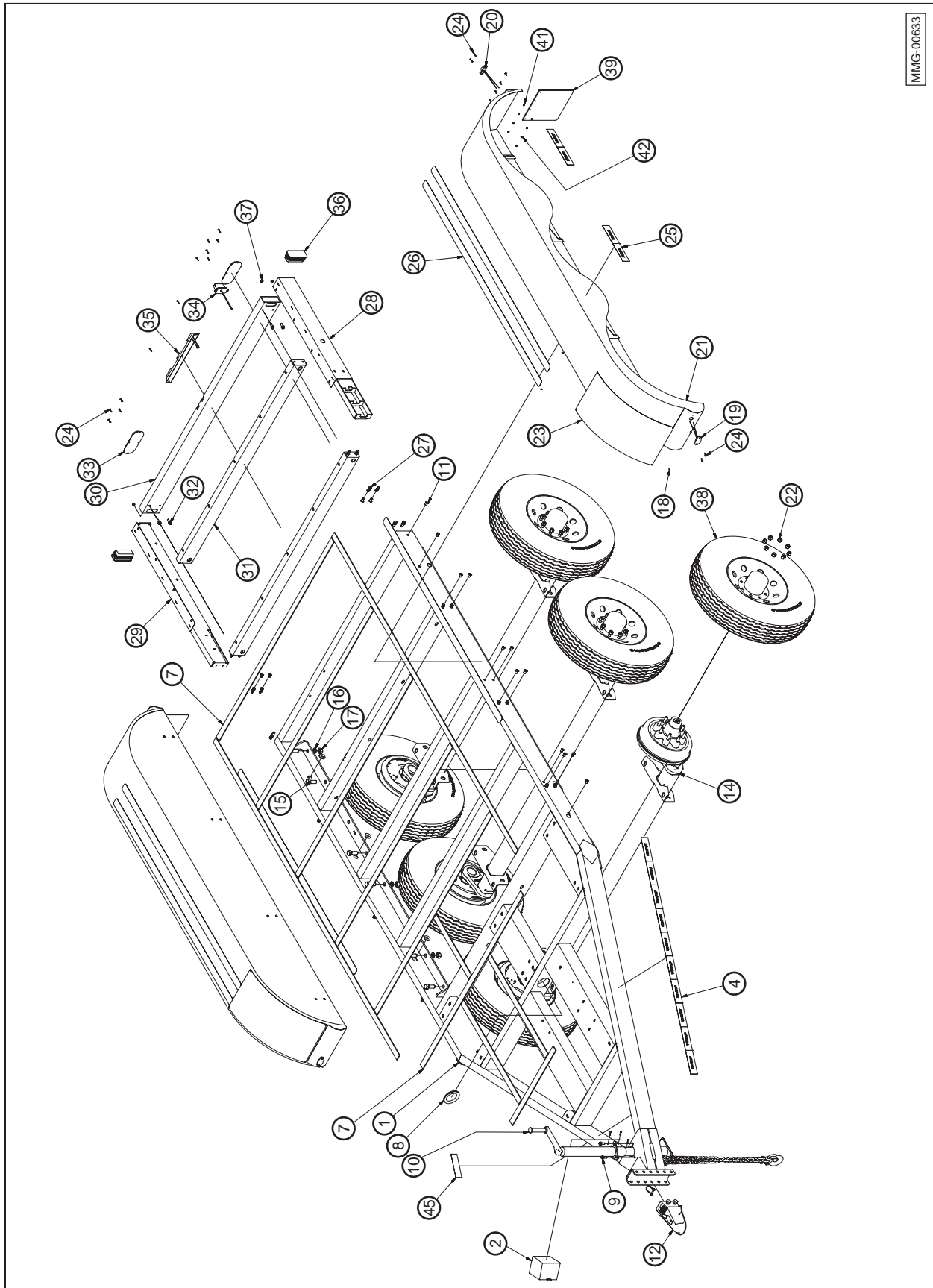

MMG-00633

Item	Qty.	Part No.	Description
1	1	32038	Frame Weldment, 990 Fuel Trailer
2	1	19275	Battery Breakaway, BA10-150
4	10	18096	Tape, Reflective Meridian 2x6x6
5	3	19564	Nut, Hex, Flanged, 3/8-16 UNC
6	1	14065	Wire Harness, Fuel Trailer (Not Shown)
7	—	—	Neoprene Strip, 3/16 x 1-1/2 (60' 6")
8	4	14062	Edging, Neoprene
9	7	19569	Bolt, Hex, Flanged, 3/8-16 x 1"
10	1	18192	Jack, Top-Wind (5000 lb. CAP.)
11	24	11550	Rivet Nut 3/8"-16 UNC
12	1	24688	Hitch Coupler 2-5/16" Adjustable
14	3	18193	Axle, 7000 lbs.
15	12	19388	Bolt, Hex, 3/4-10 x 2"
16	12	19396	Washer, Lock, Helical Spring 3/4"
17	12	19652	Nut, Hex, Heavy, 3/4-10 UNC
18	8	17041	Ø1/8" Aluminum Rivet - .126-.187 Grip
19	2	18151	Clearance Light, Amber
20	2	18229	Clearance Light, Red
21	2	32037	Fender Weldment, Triple Axle, Round
22	48	18991	Ø9/16-18 UNF x 3/4" Lug Nut
23	2	22994	Fender, Aluminum Rock Guard, Triple Axle
24	23	19779	#8-18 X 3/4" Self Drilling Zinc Screw

Item	Qty.	Part No.	Description
25	4	18096	Tape, Reflective Meridian 2x6x6
26	6	18118	Tape, Anti-Slip
27	24	11551	Screw, Cap, 3/8-16 x 1-1/4" With Loctite
28	1	22904	Rail mount Weldment, Left, Utility Box
29	1	22905	Rail mount Weldment, Right, Utility Box
30	1	22788	Rear Tube, Utility Box Frame
31	2	22984	Stiffener, Cross Frame, Utility Box
33	2	18117	Tail Light, 10 Diode, (LED STL-78RB)
34	1	17209	License Plate Light, Chrome, 5 Diode
35	1	11554	Strip Light, LED (Truck-Lite 15050R)
36	2	19619	Plug, Tube, 2" x 5"
37	4	19318	Nut, Hex, Flanged, 5/16-18 UNC
38	6	18131 17756	ST235/80R16, Tire and Steel Rim ST235/80R16-E, Tire, Aluminum Rim Assembly
39	2	19274	Flap, Mud
40	8	19141	Screw, Round Head Pan, #8-32 x 5/8
41	8	19629	Washer, Flat, 5/32" Dia.
42	8	19112	Nut, Hex, #8-32 Nylon
43	16	19349	Washer, Lock, 3/8" Dia.
44	3	17065	Grommet, 1-1/8" x 3/4"
45	1	17532	Decal, Trailer VIN# Template

17.14 UTILITY BOX AND IBC (TANK)

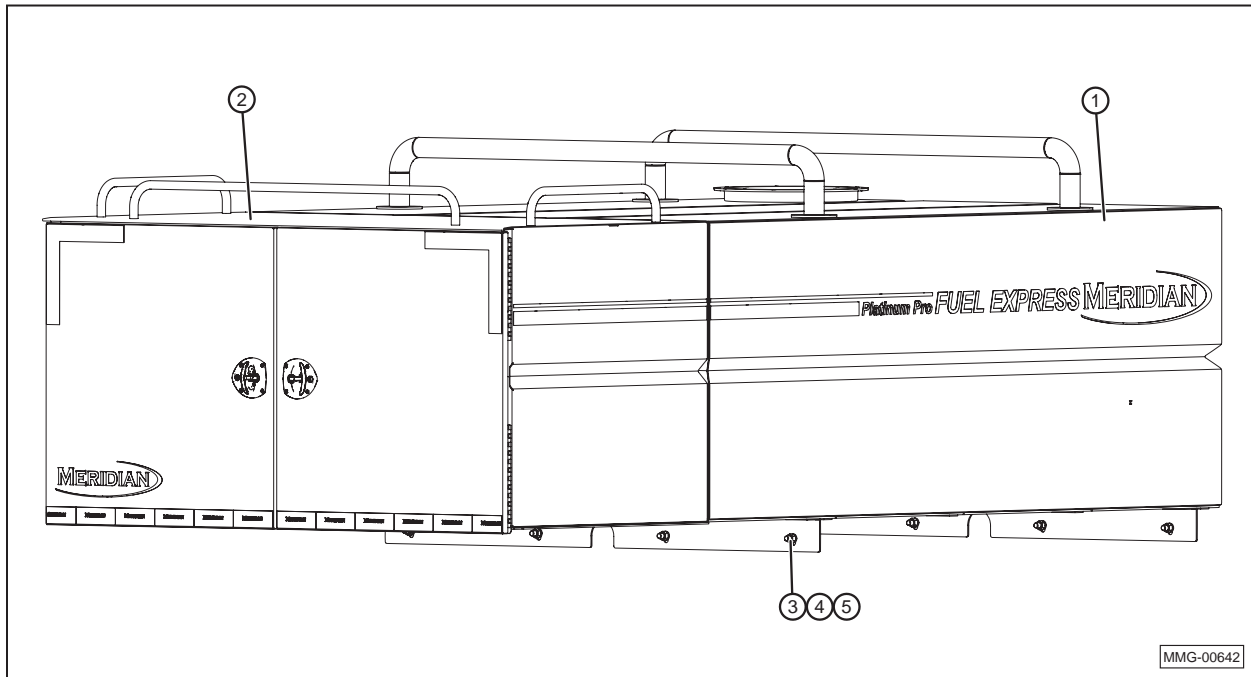

Item	Qty.	Part No.	Description
1	1	*32416XX	IBC (Tank) Weldment
2	1	*32106XX	Utility Box Assembly
3	8	19382	Nut, Hex, 5/8-11 UNC
4	8	17589	Bolt, Hex, 5/8-11 x 3-1/2
5	8	18460	Washer, Lock, 5/8

*Color of painted components is denoted by a two letter suffix as follows. MR - Meridian Red, BW - Bone White, GR - Grey

17.15 AIR AND ELECTRICAL DUAL REEL OPTION

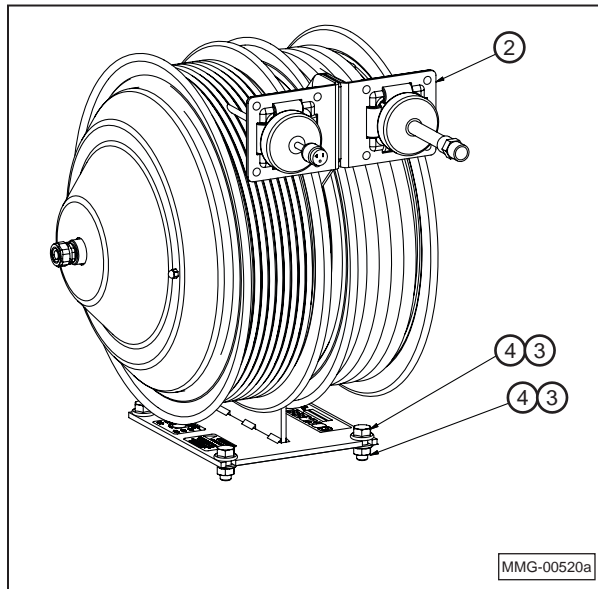

Item	Qty.	Part No.	Description
2	1	11075	Reel, Dual, Air/Electrical
3	4	18943	Bolt, Hex, Flanged, Steel, Mild, 1/2-13 x 1-1/4" Long
4	4	19595	Nut, Hex, Flanged, 1/2-13

17.16 FIRST AID KIT AND FIRE EXTINGUISHER

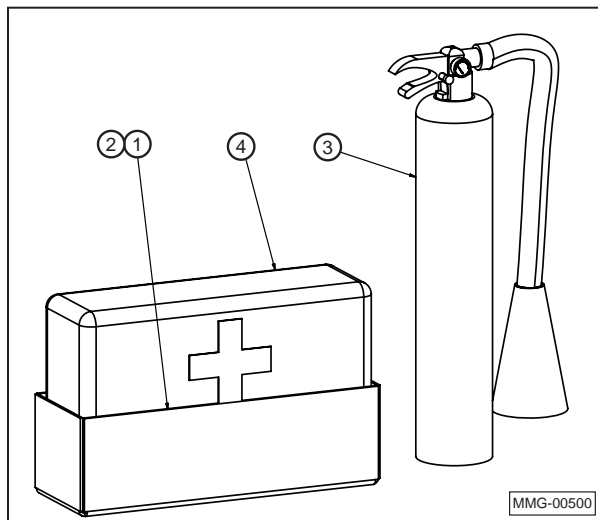

Item	Qty.	Part No.	Description
1	1	22774	Caddy, Safety Kit
2	2	19597	Screw, Hex Washer Hd, Self Drilling, 1/4-14 x 3/4
3	8	17733	Fire Extinguisher
4	1		First Aid Kit

**GUIDE
128****FLAMMABLE LIQUIDS
(NON-POLAR/WATER-IMMISCIBLE)**

ERG2012

POTENTIAL HAZARDS**FIRE OR EXPLOSION**

- **HIGHLY FLAMMABLE: Will be easily ignited by heat, sparks or flames.**
- Vapors may form explosive mixtures with air.
- Vapors may travel to source of ignition and flash back.
- Most vapors are heavier than air. They will spread along ground and collect in low or confined areas (sewers, basements, tanks).
- Vapor explosion hazard indoors, outdoors or in sewers.
- Those substances designated with a **(P)** may polymerize explosively when heated or involved in a fire.
- Runoff to sewer may create fire or explosion hazard.
- Containers may explode when heated.
- Many liquids are lighter than water.
- Substance may be transported hot.
- For UN3166, if Lithium ion batteries are involved, also consult GUIDE 147.
- **If molten aluminum is involved, refer to GUIDE 169.**

HEALTH

- Inhalation or contact with material may irritate or burn skin and eyes.
- Fire may produce irritating, corrosive and/or toxic gases.
- Vapors may cause dizziness or suffocation.
- Runoff from fire control or dilution water may cause pollution.

PUBLIC SAFETY

- **CALL EMERGENCY RESPONSE Telephone Number on Shipping Paper first. If Shipping Paper not available or no answer, refer to appropriate telephone number listed on the inside back cover.**
- As an immediate precautionary measure, isolate spill or leak area for at least 50 meters (150 feet) in all directions.
- Keep unauthorized personnel away.
- Stay upwind.
- Keep out of low areas.
- Ventilate closed spaces before entering.

PROTECTIVE CLOTHING

- Wear positive pressure self-contained breathing apparatus (SCBA).
- Structural firefighters' protective clothing will only provide limited protection.

EVACUATION**Large Spill**

- Consider initial downwind evacuation for at least 300 meters (1000 feet).

Fire

- If tank, rail car or tank truck is involved in a fire, ISOLATE for 800 meters (1/2 mile) in all directions; also, consider initial evacuation for 800 meters (1/2 mile) in all directions.

EMERGENCY RESPONSE**FIRE**

CAUTION: All these products have a very low flash point: Use of water spray when fighting fire may be inefficient.

CAUTION: For mixtures containing alcohol or polar solvent, alcohol-resistant foam may be more effective.

Small Fire

- Dry chemical, CO₂, water spray or regular foam.

Large Fire

- Water spray, fog or regular foam.
- **Do not use straight streams.**
- Move containers from fire area if you can do it without risk.

Fire involving Tanks or Car/Trailer Loads

- Fight fire from maximum distance or use unmanned hose holders or monitor nozzles.
- Cool containers with flooding quantities of water until well after fire is out.
- Withdraw immediately in case of rising sound from venting safety devices or discoloration of tank.
- ALWAYS stay away from tanks engulfed in fire.
- For massive fire, use unmanned hose holders or monitor nozzles; if this is impossible, withdraw from area and let fire burn.

SPILL OR LEAK

- ELIMINATE all ignition sources (no smoking, flares, sparks or flames in immediate area).
- All equipment used when handling the product must be grounded.
- Do not touch or walk through spilled material.
- Stop leak if you can do it without risk.
- Prevent entry into waterways, sewers, basements or confined areas.
- A vapor suppressing foam may be used to reduce vapors.
- Absorb or cover with dry earth, sand or other non-combustible material and transfer to containers.
- Use clean non-sparking tools to collect absorbed material.

Large Spill

- Dike far ahead of liquid spill for later disposal.
- Water spray may reduce vapor; but may not prevent ignition in closed spaces.

FIRST AID

- Move victim to fresh air.
- Call 911 or emergency medical service.
- Give artificial respiration if victim is not breathing.
- Administer oxygen if breathing is difficult.
- Remove and isolate contaminated clothing and shoes.
- In case of contact with substance, immediately flush skin or eyes with running water for at least 20 minutes.
- Wash skin with soap and water.
- In case of burns, immediately cool affected skin for as long as possible with cold water. Do not remove clothing if adhering to skin.
- Keep victim warm and quiet.
- Ensure that medical personnel are aware of the material(s) involved and take precautions to protect themselves.

Index

A

Additional Safety Words 3-2
Air and Electrical Dual Reel Option 17-19
Air Filter Inspection..... 11-5
Anti-Spill Inspection Manway 17-6
APPENDIX A..... 17-20
Approved Fuel 11-4
Axle Bolts 11-7
Axles..... 12-5

B

Battery..... 11-2
Battery Maintenance 11-3
Battery Replacement and Maintenance Tips... 11-2
Battery Safety 3-7, 11-2
Before Starting Gas Engine..... 2-2
Bolt Specifications 5-3
Bolt Torque Values 5-3

C

Canada Regulatory Information..... 3-7
Change Engine Oil..... 11-4
Changing Diesel Fuel Filter..... 11-6
Charging the Battery 11-7
Check Oil Level 2-2
Component Nomenclature and Location 6-1
Congratulations 2-1
Connecting the Trailer 8-2
Continuous Improvement Process 2-1
Cowling Assembly..... 17-13

D

Daily Pre-Operation Checklist 7-2
Decals and Safety Signs..... 17-9
DEF and Diesel Fuel Tanks..... 9-3
DEF Disposal 9-10
DEF Pump Assembly..... 17-4
DEF Solution 9-9
DEF Solution Safety Practices 9-9
DEF Tank Assembly 17-5
DEF Tank Drain Plug 12-5
Diesel Fuel Pump..... 17-2, 17-3
Diesel Fuel Safety..... 3-5
Disposal of Equipment at End of Useful Life 2-1
Door Keys..... 2-2

17-22

Door Light Switch 12-6

E

Emergency Response..... 4-4
Engine 17-2
Engine Circuit Protection 11-5
Engine Oil..... 11-4
Engine to Pump Connection
(Gasoline Engine Option Only) 11-6
Equipment Break-In Period 7-1
Equipment Components and Controls 6-1
Explosion Hazards..... 3-8
Eye Protection..... 3-6

F

Filling Machinery Using
12 Volt Electric Fuel Pump 9-4
Filling Machinery Using
Gasoline Powered Fuel Pump 9-5
Filling the DEF Tank on Machinery..... 9-7
Filling the Fuel Trailer with Diesel Fuel 9-3
Fire and Explosion Hazards..... 3-5
Fire Extinguisher 9-2
Fuses..... 11-3

G

Gasoline Engine and Controls..... 6-2
Gasoline Engine (Optional) 11-4
General Hazards..... 3-7
General Information 10-1
General Safety..... 3-4, 11-1
Generator/Compressor Option (2-In-1) 17-8
Generator/Welder/Compressor Option (3-In-1) 17-7

H

Hazard Avoidance 3-3
How to Install Safety Signs..... 4-1

I

Ingestion..... 3-6
Inhalation Hazard 3-5
Inspections for 1/2..... 7-1
Installing Fuel Placards 4-3
INTRODUCTION 2-1

M

Maintenance 11-1
Maintenance Safety 3-5

O

OEM LITERATURE	14-1
Operating Safety	3-5, 9-1
Operation	9-1
Operator Orientation	2-1
Optional Compressor	11-8
Options	13-1
Overall Dimensions	5-1
Owner/Operator	2-1

P

PARTS	17-1
Personal Protection/Important Information	3-3
Placing in Storage	10-1
Pre-Operating Instructions	7-1
Pre-Operation Checks	9-2
Prime DEF Pump	2-2
Prime Gasoline Engine Fuel Pump (Diesel Only)	2-2
Prohibited Actions	3-3

R

Rear Mounted Tool Box	11-8, 13-1
Removing from Storage	10-1
Replacing the Battery	11-7

S

Safety	3-1, 11-1
Safety Icon Nomenclature	3-3
Safety Sign Locations	4-1
Safety Signs	4-1
Safety Training	3-2
Service	12-1
Service Checks	12-2
Service Record Chart	12-1
Shock Hazards	3-7
Sign-Off Form	3-9
Skin Protection	3-6
Spare Tire Option	17-12
Specifications	5-2
Spill Reporting	3-7
Static Electricity Hazard	3-5
Storage	9-10, 10-1
Storage Precautions	3-6
Storage Safety	3-5

T

Tandem Axle Trailer	17-14
Tank Replacement	11-8

Testing the Battery	11-6
Tires	12-5
Towing	8-1
Trailer Breakaway System	11-6
Transport Safety	3-5, 8-1
Triple Axle Trailer	17-16
TROUBLESHOOTING	15-1
Troubleshooting Chart	15-1

U

U.S. Federal	3-6
Using DEF	9-10
Utility Box and IBC (Tank)	17-18
Utility Box Assembly	17-10

V

Ventilation Hazard	3-7
--------------------------	-----

W

WARRANTY	16-1
Warranty Statement	16-1
Welding Repairs	12-5
Wheel Bearings	11-2
Wheel Bolt Torque	11-7
Winterizing the DEF System	10-1

MERIDIAN MANUFACTURING INC.

With over 65 years of experience,
Meridian is your storage and handling expert.



AGRICULTURAL



INDUSTRIAL



OIL & GAS

Cambridge Office

605 Sheldon Drive
Cambridge, ON N1T 2K1
PH: 519.620.6004
TF: 855.346.3712
FX: 519.620.6041

Camrose Office

4232 - 38 St.
Camrose, AB T4V 4B2
PH: 780.672.4516
TF: 800.830.2467
FX: 780.672.4759

Lethbridge Office

3125 - 24 Ave. N.
Lethbridge, AB T1H 5G2
PH: 403.320.7070
TF: 800.661.1436
FX: 403.320.7579

Regina Office

PO Box 1996
Regina, SK S4P 3E1
PH: 306.545.4044
TF: 800.667.5904
FX: 306.545.4216

Storm Lake Office

2902 Expansion Blvd.
Storm Lake, IA 50588
PH: 712.732.1780
TF: 800.437.2334
FX: 712.732.1028

Winkler Office

Box 760, 275 Hespler Ave.
Winkler, MB R6W 4A8
PH: 204.325.7883
TF: 800.665.7259
FX: 204.325.5556



www.meridianmfg.com